

# Central Hydraulics Inc.

Specializing in sales and repairs  
of hydraulic hose, pumps, motors,  
cylinders, valves, & components

**EAT•N**  
Aeroquip



## MANUFACTURERS

**AEROQUIP**  
**APSCO INC**  
**ALEMITE**  
**BAND-IT**  
**BOSTON**  
**BRAND HYDRAULICS**  
**BUCHER**  
**BVA HYDRAULICS**  
**CIM-TEK FILTERS**  
**CROSS MFG**  
**CURTIS TOLEDO**  
**DAMAN**  
**DELTRON**  
**DIXON**  
**DK-LOK**  
**DONALDSON**  
**DYNAMIC**  
**ENERGY MFG**  
**FABCO-AIR**  
**FILL-RITE**  
**FOSTER**  
**GRACO**  
**HANNAY**  
**HEDLAND & FLO-TECH**  
**HOSTRACT REELS**  
**HUSKY**  
**HYDRA-MOUNT**  
**HYDRAULICS INC**  
**HYVAIR**  
**KURIYAMA - PIRANHA**  
**MILTON INDUSTRIES**  
**NYCOIL - RECTUS - TEMA**  
**PERMCO**  
**REVCO WORLD WIDE**  
**SPX STONE**  
**STRIDE TOOL**  
**STUCCHI**  
**SUPER SWIVELS**  
**SUTTNER**  
**WHITE DRIVE PRODUCTS**  
**YUKEN**  
**ZERO-MAX/ HELLAND**

## PRODUCTS OFFERED

**Hose, Fittings, Adapters, Flexmaster Joints**  
**Pneumatic Valves - Electric and Manual**  
**Lube Equipment & Fluid Handling Products**  
**Punch Type Clamps & Tools**  
**Air, Water, Fuel, Chemical Hose**  
**Valves, Stackable, Mono Block**  
**Monoblock & Sectional Directional Control Valves**  
**High Pressure Pumps & Rams to 10k psi**  
**Fuel Filtration Products**  
**Cylinders, Valves, Gear Pumps & Motors**  
**Hose Cut-Off Machines**  
**Hydraulic Valve Manifolds**  
**Needle, Flow Control, Check & Cartridge Valves**  
**Valves, Couplings, Camlocks**  
**Instrumentation Fittings & Valves**  
**Hydraulic Filters & Components**  
**Pressure Gages, High Pressure Ball Valves**  
**Hydraulic Control Valves**  
**Filters Regulators & Lubricators**  
**Fuel Transfer Pumps & Meters**  
**Water & Air Disconnects**  
**Bulk Fluid and Grease Dispensing Air Pumps**  
**Best Quality Hose Reels for Industry**  
**Testers & Flow Meters for Liquid, Air & Compressed Gases**  
**Economical Hose Reels**  
**Fuel Nozzles & Accessories**  
**Pump/Motor Mounting Brackets**  
**Full Time Hydraulic 3000psi Live Swivels**  
**NFPA Valves and Accessories**  
**Sewer Cleaning Hose**  
**Air Accessories & Fittings**  
**European Quick-Connect Couplings**  
**Gear Pump, Motors, & Dump Pumps**  
**Jaw-Type Couplings(L095, L100, L110, L150)**  
**AC/DC Hydraulic Power Units**  
**Professional Tube Bending & Flaring Tools**  
**Hydraulic Quick-Disconnect Couplers**  
**Live Swivels Oil, Water & Air up to 5000psi**  
**Pressure Washer Accessories**  
**LSHT Motors and Brakes**  
**Solenoid Operated Directional Control Valves**  
**Overhung Load Adapters**



Kuriyama of America, Inc.



**Central Hydraulics Inc.**

**386-253-2568**

**1580 North Nova Road**  
**Daytona Beach, FL 32117**

**www.CentralHydraulics.com**  
*Tampa Ocala Leesburg Cocoa*

# CENTRAL HYDRAULICS INC.

•Daytona Beach •Cocoa •Leesburg •Ocala •Tampa 1-800-264-9571

## Hydraulic Hoses



Part#	MAX PSI	Min.Bend Radius (in)
GH781-4	6500	2.00
GH781-6	5300	2.50
GH781-8	4500	3.50
GH781-10	4000	4.00
GH781-12	3500	4.75
GH781-16	3000	6.00
GH781-20	2500	8.25
GH781-24	2000	10.0
GH781-32	1600	12.5

**Two Wire** Meets or Exceeds SAE 100R16 Type S, EN857 2SC, ISO 11237-1 Type 2SC -40 degrees F. to +212 degrees F. Uses: Hydraulic system service with petroleum and water-base fluids, for general industrial service.



Part#	MAX PSI	Min.Bend Radius (in)
GH793-4	6500	4.00
GH793-6	5800	5.00
GH793-8	5000	7.00
GH793-10	4000	8.00
GH793-12	3500	9.50
GH793-16	3000	12.00
GH793-20	2500	16.5
GH793-24	2000	20
GH793-32	1600	25

**Two Wire** Meets or Exceeds SAE 100R2AT Type S, EN853 2SC, ISO 1436-1 Type 2SN -40 degrees F. to +212 degrees F. Uses: Hydraulic system service with petroleum and water-base fluids, for general industrial service.



Part#	MAX PSI	Min.Bend Radius (in)
GH663-4	3700	4.00
GH663-6	3400	5.00
GH663-8	2900	7.00
GH663-12	2000	9.50
GH663-16	1500	12.00
GH663-20	1000	16.50
GH663-24	750	20.00
GH663-32	600	25.00

**One Wire** SAE 100R1AT Type S, EN853 1SC, ISO 1436-1 Type 1SN -40 degrees F. to +212 degrees F. Uses: Hydraulic system service with petroleum and water-base fluids, for general industrial service.

# CENTRAL HYDRAULICS INC.

•Daytona Beach •Cocoa •Leesburg •Ocala •Tampa 1-800-264-9571

## Hydraulic Hoses



Part#	MAX PSI	Min.Bend Radius (in)
GH120-4	6000	2.00
GH120-6	5000	2.50
GH120-8	4500	3.50
GH120-10	4000	4.00
GH120-12	3000	4.75
GH120-16	2800	12.00

**Two Wire** Meets or Exceeds SAE 100R2AT Type S, EN853 2SN, ISO 1436-1 Type 2SN -40°F. to +300°F. Uses: Hydraulic system service with petroleum, fire resistant and water-base fluids, fuel and lubricating systems.



Part#	MAX PSI	Min.Bend Radius (in)
GH493-6	6500	2.50
GH493-8	6000	3.50
GH493-10	6000	4.00
GH493-12	5500	4.75
GH493-16	5100	6.00
GH493-20	4500	8.25
GH493-24	4000	10.00
GH493-32	4000	12.50

**Four Spiral Wire** SAE 100R12, EN 856 Type R12 -40°F to +250°F. Hydraulic system service with petroleum and water-base fluids, for general industrial service.



Part#	MAX PSI	Min.Bend Radius (in)
FC254-08	7700	8.00
FC254-12	7200	11.00
FC254-16	5900	12.00
FC254-20	5100	16.50
FC254-24	4350	20.00

**Four Heavy Spiral Wire** Exceeds SAE 100R11, EN 856 4SP -40°F to +250°F. Hydraulic system service with petroleum and water-base fluids, for general industrial service.



Part#	MAX PSI	Min.Bend Radius (in)
FC273-20	5000	16.50
FC273-24	5000	20.00

**Six Heavy Spiral Wire** SAE 100R13, EN 856 Type R13 -40°F to +250°F. HYdraulic system service with petroleum and water-base fluids, for general industrial service.

# CENTRAL HYDRAULICS INC.

•Daytona Beach •Cocoa •Leesburg •Ocala •Tampa 1-800-264-9571

## Hydraulic Hoses



Part#	Max. PSI	Hose I.D. (in)	Min. Bend Radius (in)
FC300-4	3000	0.19	3.00
FC300-5	3000	0.25	3.38
FC300-6	2250	0.31	4.00
FC300-8	2000	0.41	4.62
FC300-10	1750	0.50	5.50
FC300-12	1500	0.63	6.50
FC300-16	800	0.88	7.38
FC300-20	625	1.12	9.00
FC300-24	500	1.38	10.50
FC300-32	300	1.81	13.25

### Single Wire Braid

Exceeds SAE100R5 -55°F to +300°F

\*Except air +250°F



Part#	Max. PSI	Hose I.D.	Min. Bend Radius (in)
FC234-5	1500	0.25	1
FC234-6	1500	0.31	1.25
FC234-8	1250	0.41	1.75
FC234-10	1250	0.50	2.25
FC234-12	750	0.63	2.75
FC234-16	400	0.88	3.5

### High Temperature Fuel and Oil

Fire Resistant USC G/ MMT, NMMA/BIA -40°F to +300°F.



Part#	Max. PSI	Hose I.D.	Min. Bend Radius (in)
FC332-4	250	0.25	3
FC332-6	250	0.31	3
FC332-8	250	0.41	5
FC332-10	250	0.50	6
FC332-12	250	0.63	7

### Textile Braid

-40°F to +300°F.

\*Except air +250°F. Water +180°F.

# CENTRAL HYDRAULICS INC.

•Daytona Beach •Cocoa •Leesburg •Ocala •Tampa 1-800-264-9571

## Easy Couple Hose



Boston Easy Couple

### BOSTON

### Push-on Hose

Low Working Pressure

#### Applications:

- Pneumatic tools on production line; convey air, water, oils, etc.; transfer lubricated air to valves and cylinders; low pressure hydraulics
- Black hose cover only has been accepted by MSHA (2G-13C) for underground use in lube oil lines, pneumatic, and low pressure hydraulics

**Tube:** Vinyl Nitrile (RMA Class A)

**Reinforcement:** Fiber, 1 Braid

**Cover:** Neoprene MSHA approved (B K), Vinyl Nitrile (BU,GY,RD,YW,GN)

**Color:** Black(BK), Gray(GY), Blue(BU), Red(RD), Green(GN), & Yellow(YW)

**Temperature Range:** -40°F to +200°F

**Type of Branding:** Ink Print

**Working Pressure:** 250 PSI

**Type of Coupling:** Barbed inserts or Push on Couplings (clamps not required)

#### \*NOT FOR GASOLINE

##### Type of Coupling:

- Neoprene cover
- Vinyl nitrile cover
- Nitrile tube (RMA Class A)
- Continuous permanent brand
- Six colors
- Light weight & flexible
- Easily Coupled
- Braid reinforcement

##### Advantage:

- Abrasion, oil, and weather resistant
- Good oil resistance
- Easy identification
- Color coded air systems
- Easy to handle
- Use push-on couplings: no need for clamps
- Better coupling retention for impluse applications

##### Markets:

- Assembly/Manufacturers
- Mining
- Construction Industry
- Plastic Molding

##### Uses:

- Diesel Fuel, Water, Oils (not recommended for gasoline).

Part #	Nominal I.D. (in)	Braid	Nominal O.D. (in)	Approx. lbs./100ft	Max PSI	Min Bend Radius (in)	Standard Reel Length
EC4	1/4"	1	1/2"	8	250	3	500
EC6	3/8"	1	21/32"	13	250	3	500
EC8	1/2"	1	3/4"	15	250	5	500
EC10	5/8"	1	15/16"	20	250	6	250
EC12	3/4"	1	1-1/16"	26	250	7	250

# CENTRAL HYDRAULICS INC.

•Daytona Beach •Cocoa •Leesburg •Ocala •Tampa 1-800-264-9571

## Synfex-30CT

### Constant Pressure Hose

#### Applications

- Forklift
- Construction
- General Hydraulics
- Chemical and Gas Transfer
- Agricultural Equipment
- Material Handling
- Freezer Applications
- Machine Tools and Robotics
- Lubrication Equipment
- Mobile Equipment
- Portable Hydraulic Tools

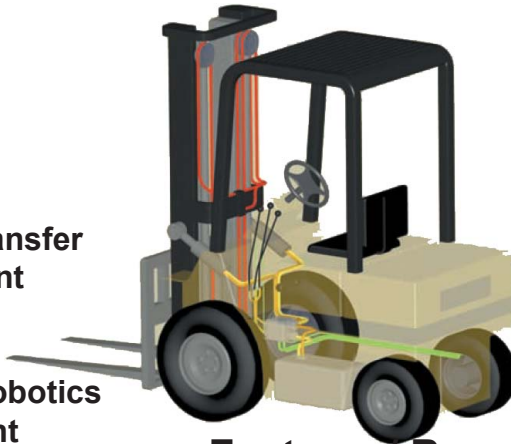

#### Lengthens Life of Hydraulic System

Pump and cylinder life is lengthened considerably by its shock absorbing design.

#### Working Pressure

3,000 psi (207 bar). The high working pressure (SAE 100r18) and small O.D. design make this hose backward compatible with most forklift pulley applications.

#### Features/ Benefits

##### Extremely Flexible

The 30CT products are constructed to be more flexible, even in cold temperatures. This hose is ideal for extreme flexing and over-the-mast applications. Fibar reinforcement eliminates hose fatigue failure found in most rubber wire braided hoses.

##### Small Outside Diameter

A smaller O.D. makes the 30CT family of products the perfect replacement and original equipment hose choice.

Fits the existing pulley

##### Lightweight, Easy Field Repair

The lightweight yet rugged construction of the 30CT allows for the quickest field repair in the market today. Time trials have shown that repairs can take 5 minutes or less!



#### Cold Temperature:

Synfex 30CT exceeds SAE 100r18 and is designed for a wider temperature range, -65°F to 200°F (-54°C to 94°C), making it a perfect fit for all your hydraulic 3,000 psi needs, including freezer applications.

Single Part #	Twinline Part #	Nom. I.D.	Max. O.D.	Max. Bend Radius	Max. Working Pressure	Min. Burst Pressure	Fitting Series	Swag Die Part # 4540
30CT-03	N/A	3/16"	.420"	1	3,000	12,000	903	303
30CT-04	3770-20c33	1/4"	.478"	1-1/4	3,000	12,000	903	3W4
30CT-05	3770-20c43	5/16"	.610"	1-1/2	3,000	12,000	903	305
30CT-06	3770-20c53	3/8"	.660"	2	3,000	12,000	903	306
30CT-08	3770-20c63	1/2"	.850"	3-1/2	3,000	12,000	903	A08
30CT-10	N/A	5/8"	1.062"	4	3,000	12,000	90N	N10

# CENTRAL HYDRAULICS INC.

•Daytona Beach •Cocoa •Leesburg •Ocala •Tampa 1-800-264-9571

## Sewer Hose

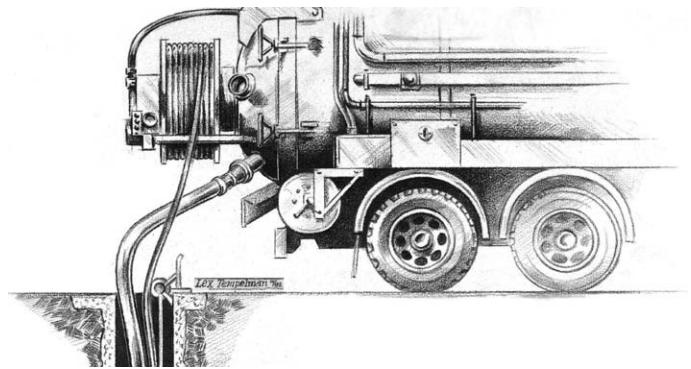
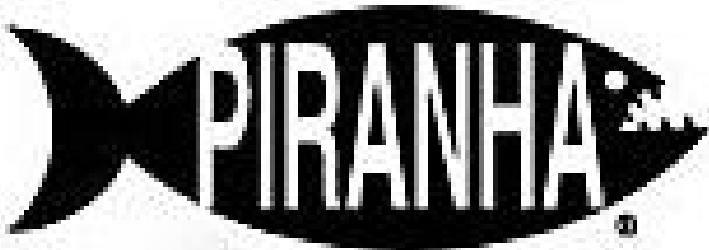

### SEWER HOSES



#### SP HOSE

#### CONSTRUCTION

A yellow olefin tube, single high tensile braid reinforcement, and an orange polyether-urethane cover.

Temperature Range: -40°F to 122°F

400ft / 500ft / 600ft Lengths  
with male NPT ends.

#### KEY CHARACTERISTICS - SH HOSE

Hose Type	Hose Color	Hose I.D.	Hose O.D.	Max. Operating Pressure	Min. Burst Pressure	Min. Bend Radius
SP-10	Orange	.625	0.96	2,500 psi	6,250 psi	4"
SP-12	Orange	.750	1.18	2,500 psi	6,250 psi	5"
SP-16	Orange	1.00	1.46	2,500 psi	6,250 psi	6"
SP-20	Orange	1.26	1.80	2,500 psi	6,250 psi	8"

# CENTRAL HYDRAULICS INC.

•Daytona Beach •Cocoa •Leesburg •Ocala •Tampa **1-800-264-9571**

## T600AA - Hard Wall Marine Exhaust Hose USCG/SAE J1527 B2

## Petroleum



**Now In Stock!**



### APPLICATION

Fuel, oil and hydraulic fluids suction and delivery with up to 50% aromatic content. Suitable for exhaust gas from water cooled stationary or marine diesel engines.

### COVER

Black NBR/PVC blend — abrasion, ozone, hydrocarbon and fire resistant.

### REINFORCEMENT

High tensile textile cords and 4 highly flexible steel helix wires.

### TUBE

Black NBR — exhaust gas, fuel and fire resistant.

### BRANDING

ALFAGOMMA – ITALY T600 MARINE EXHAUST/  
FUEL S & D – <SIZE> – USCG/SAE J1527 TYPE B2  
(in red letters)

### TEMPERATURE RANGE

-22°F to 212°F

### STANDARD LENGTH

25 or 50 feet

### BRANDING

ALFAGOMMA – ITALY T600 MARINE EXHAUST/  
FUEL S & D  
– <SIZE> – USCG/SAE J1527 TYPE B2 (in red letters)



Kuriyama of America, Inc.

SERIES NO.	Nominal ID	Nominal OD	APPROX. WT. lbs./100 ft.	MAX. REC. WP (PSI)	MIN. BEND RADIUS (in.)
	(in.)	(in.)			
T600AA062	5/8	1.02	36	75	2
T600AA075	3/4	1.18	44	75	2 1/4
T600AA067	7/8	1.26	48	75	2 3/4
T600AA100	1	1.38	54	75	3 1/4
T600AA112	1 1/8	1.50	58	75	3 1/4
T600AA125	1 1/4	1.65	65	75	3 3/4
T600AA137	1 3/8	1.77	69	75	4 1/4
T600AA150	1 1/2	1.89	75	75	4 1/2
T600AA162	1 5/8	2.05	81	75	5
T600AA175	1 3/4	2.16	86	75	5 1/4
T600AA189	1 7/8	2.28	91	75	5 3/4
T600AA200	2	2.40	97	75	6
T600AA225	2 1/4	2.64	108	75	6 3/4
T600AA238	2 3/8	2.76	124	75	7
T600AA250	2 1/2	2.87	130	75	7 1/2
T600AA275	2 3/4	3.11	141	75	8 1/4
T600AA300	3	3.39	152	75	9
T600AA350	3 1/2	3.94	190	75	10 1/2
T600AA400	4	4.41	212	75	12
T600AA450	4 1/2	5.08	270	75	13 1/2
T600AA500	5	5.55	302	75	15

Fax: **386-257-5728** Tele. **1-800-264-9571** [sales@centralhydraulics.com](mailto:sales@centralhydraulics.com) [www.centralhydraulics.com](http://www.centralhydraulics.com)



# CENTRAL HYDRAULICS INC.

•Daytona Beach •Cocoa •Leesburg •Ocala •Tampa 1-800-264-9571

## Hose and Tube Clamps



### Single Clamps

Clamp I.D.	Part #
0.250	S-1004S
0.375	S-1006S
0.405	S-1007S
0.500	S-2008S
0.540	S-2009S
0.625	S-2010S
0.675	S-2011S
0.750	S-3012S
0.840	S-3014S
0.875	S-3015S
1.000	S-3016S
1.050	S-4017S
1.125	S-4018S
1.250	S-5020S
1.315	S-5021S
1.500	S-5024S
1.660	S-5027S
1.750	S-6028S
1.900	S-6030S
2.000	S-6032S
2.375	S-7038S

Clamp I.D.	Part #
0.250	T-1004S
0.375	T-1006S
0.405	T-1007S
0.500	T-2008S
0.540	T-2009S
0.625	T-2010S
0.675	T-2011S
0.750	T-3012S
0.840	T-3014S
0.875	T-3015S
1.000	T-3016S
1.050	T-4017S
1.125	T-4018S
1.250	T-5020S
1.315	T-5021S
1.500	T-5024S
1.660	T-5027S

Measure the O.D. of your hose, tube, or pipe to figure out which clamp you need. Bottom plate welds in place.

### Twin Clamps



# CENTRAL HYDRAULICS INC.

•Daytona Beach •Cocoa •Leesburg •Ocala •Tampa 1-800-264-9571

## Mill Discharge Hose

Part #	Hose Size and Ends
SNA MD15X50-NPSH	1.5" X 50' NPSH
SNA MD15X50-NST	1.5" X 50' NST
SNA MD15X100-NPSH	1.5" X 100' NPSH
SNA MD15X100-NST	1.5" X 100' NST
SNA MD15X50-NPSH	2" X 50' NPSH
SNA MD15X50-NPSH	2" X 100' NPSH



**Coupled**  
Mill Discharge Hose



**Brass**

### Fog Nozzles



**Plastic**

Part #	Hose Size and Ends
1-1/2" NST	JSI FN150BNST
1-1/2"NPSH	JSI FN150B
2-1/2" NST	JSI FN250B

Part #	Hose Size and Ends
1-1/2" NST	JSI FN150NST
1-1/2"NPSH	JSI FN150
2" NPSH	DIX CFB20155

**Bulk**  
Mill Discharge Hose



Part #	Hose Size and Ends
SNA MD15X50W	1.5" X 50'
SNA MD15X100W	1.5" X 100'
SNA MD20X50W	2" X 50'
SNA MD20X100W	2" X 100'
SNA MD25X50W	2.5" X 50'
SNA MD25X100W	2.5" X 100'
SNA MD30X50W	3" X 50'
SNA MD30X100W	3" X 100'

# CENTRAL HYDRAULICS INC.

•Daytona Beach •Cocoa •Leesburg •Ocala •Tampa 1-800-264-9571

## Air Brake Tubing



### Applications:

- Truck, bus and commercial vehicle air brake systems.
- Trailer air brake systems.
- Auxiliary air systems.



Kuriyama of America, Inc.

### Construction:

- Kuri Tec® Endure™ Air Brake Tubing utilizes DuPont™ Hytrel® material.
- Tube: Polyester elastomer (natural).
- Reinforcement: Polyester yarn.
- Cover: Polyester elastomer (colored).
- Stock colors: Black, Blue, Red. Other colors available on request.

### Compliances:

- Meets DOT FMVSS 106.
- Meets performance requirements of SAE J844 Type B.

### Service Temperature Range:

-85°F (-65°C) to +200°F (+93°C)

Kuri Tec® Endure™ utilizing DuPont™ Hytrel® material offers a superior service temperature range than traditional nylon tubing which contributes to longer service life.

**More Flexible & Retains Flexibility Longer!**  
Kuri Tec® Endure™ retains its flexibility longer than traditional nylon tubing in harsh **heat, cold and oil** conditions.  
Easy to install – fits tight corners.

**Industry Leading IMPACT Strength and Vibration Cracking Resistance.**  
The Kuri Tec® Endure™ engineered formulation retains its flexibility and resists impact cracking in both high **heat** and sub-zero **cold** weather conditions; providing longer service life than traditional nylon tubing in these harsh conditions.

**Exceeds Industry Performance Standards.**  
Kuri Tec® Endure™ far surpasses traditional nylon tubing for heat aging and heated oil aging, while retaining its superior formulation features and flexibility!

### Nominal Specifications

Standard Stock Colors: 151BK Black 151BL Blue 151RD Red	Nominal OD (in.)	Nominal ID (in.)	Nominal Wall (in.)	Minimum Burst (psi @ 70°F)	Standard Lengths Spool	Aprox. Weight per Package Spool	Size Code	Min Bend Radius @ 70°F
	3/8	0.251	0.062	1,400	500 ft.	17.0 lbs	06	1.5"
	1/2	0.376	0.062	950	500 ft.	23.0 lbs	08	2.5"
	5/8	0.441	0.094	900	250 ft.	22.0 lbs	10	3.0"
	3/4	0.566	0.094	850	250 ft.	27.0 lbs	12	3.5"

Fax: 386-257-5728 Tele. 1-800-264-9571 sales@centralhydraulics.com www.centralhydraulics.com

**KUR-206-F-01**

# CENTRAL HYDRAULICS INC.

•Daytona Beach •Cocoa •Leesburg •Ocala •Tampa 1-800-264-9571

## Hose Sleeves and Wraps

# FireSleeve

Sizes range from

Part #	I.D.
PJA8	1/2"
PJA10	5/8"
PJA12	3/4"
PJA16	1"
PJA20	1-1/4"

Part #	I.D.
PJA24	1-1/2"
PJA32	2"
PJA40	2-1/2"
PJA48	3"
PJA56	3-1/2"



Designed to protect hoses, wires and cables from the hazards of high heat and occasional flame. It protects continuously to 500°F and will withstand a molten splash at 2200°F. Made of either knitted or braided fiberglass yarns in a flexible substrate that is then coated with high-grade silicone rubber.

### PHYSICAL PROPERTIES

FIBERGLASS		SILICONE RUBBER	
Fiber Type	E Glass	Durometer, Shore A	-initial 35 -aged 240hrs.@ 200C° 45
Breaking Tenacity	1.71 gf/TEX Std. 1.71 gf/TEX Wet.		
Tensile Strength	450,000-500,000 psi.	Tensile Strength (psi)	875 800
Breaking Elongation	4.81% Std. 4.81% Wet.	Elongation %	500 200
Elastic Recovery	100%	Flammability, UL94	V-1
Average Stiffness	2824.3 cn/TEX	Dielectric Strength (volts/mil)	485
Specific Gravity	2.54-2.69	Resistant to hydraulic fluids, lubricating oils, and fuels, it insulates against energy loss in piping and hosing; protects employees from burns; and allows "bundling" of wires, hoses, and cables. The braided version allows qualified hose assemblies to pass AS1055D testing unser stated flow and pressure conditions.	
Effect of Heat	Will not burn Retains 75% Tensile at 343C° Softens at 732-877°C Melts at 1121-1182°C		
Effect of Acids and Alkalis	Resistance to acids is fair. Good resistance to most alkalis		
Effect of bleaches and solvents	Unaffected		

# CENTRAL HYDRAULICS INC.

•Daytona Beach •Cocoa •Leesburg •Ocala •Tampa 1-800-264-9571

## Hose Sleeves and Wraps

### Heavy Wall High Density Spiral Hose Wrap

#### Advantages:

- ADDS CRUSH PROTECTION
- ABRASION PROTECTION
- BUNDLES HOSES
- EASY TO INSTALL

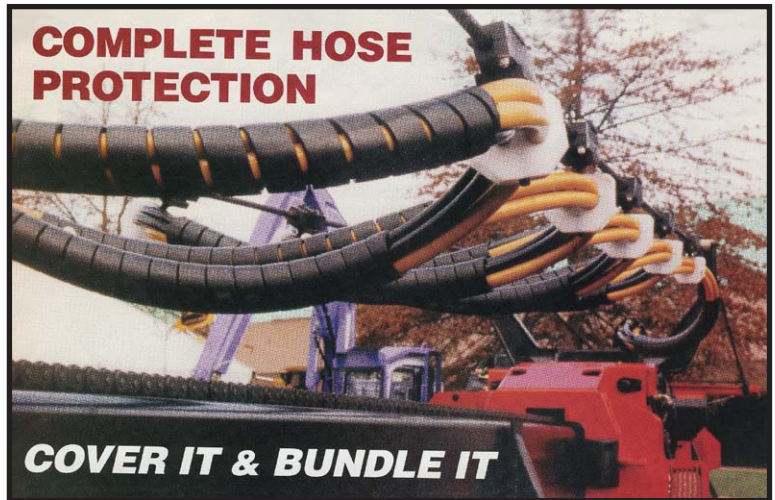

RATED FROM -180°F TO 250°F



BLACK WRAP IS **IN STOCK**.  
CUT LENGTHS AVAILABLE.

6 Other colors available in  
BOX QUANTITIES ONLY.

Part #	I.D. Inches	Box Quantity
93050	1/2" #4 Hose(1/4")	100 F.T.
93075	3/4" #6 Hose (3/8")	100 F.T.
93100	1" #8 & #10 Hose (1/2n & 5/8")	100 F.T.
93125	1-1/4" #12 Hose (3/4")	100 F.T.
93150	1-1/2" #16 & #20 Hose (1" & 1 Y4")	100 F.T.
93200	2" #24 Hose (1 1/2")	50 F.T.
93250	2-1/2" #32 Hose (2")	50 F.T.
93300	3" Used Mainly For Bundling	50 F.T.
93350	3-1/2" Used Mainly For Bundling	30 F.T.
93400	4" Used Mainly For Bundling	30 F.T.
93600	6" Used Mainly For Bundling	20 F.T.



# CENTRAL HYDRAULICS INC.

•Daytona Beach •Cocoa •Leesburg •Ocala •Tampa 1-800-264-9571

## Stainless Steel Products



Crimp Fittings



Adapters



Instrumentation  
Tube Fittings



Weld-Ons



Hose Barbs



Push-Ons



Reuseable



Flange Adapters



Metric Tubing



Valves



Custom Fittings









Accessories

# CENTRAL HYDRAULICS INC.

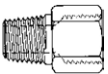
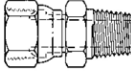
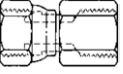
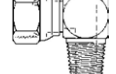
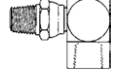
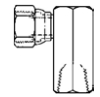
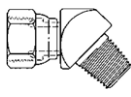
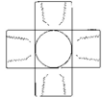

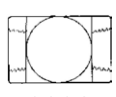

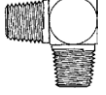
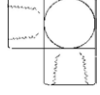
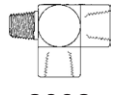
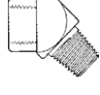

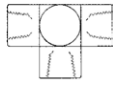
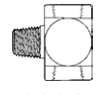

•Daytona Beach •Cocoa •Leesburg •Ocala •Tampa 1-800-264-9571

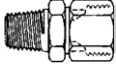
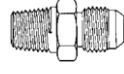
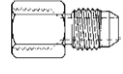
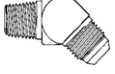
## Fittings and Adapters





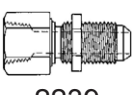
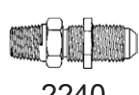
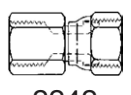

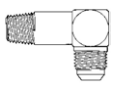
### NPT to NPT FITTINGS

 2040	 2045	 2046	 2047	 2252
 2048	 2049	 2080	 2081	 2096
 2082	 2083	 2085	 2087	 2092
 2088	 2089	 2090	 2091	

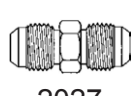
### NPT to JIC FITTINGS

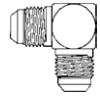
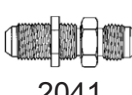
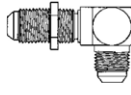
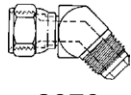
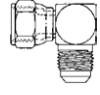
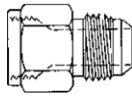
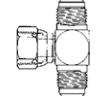
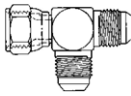
 2018	 2021	 2022	 2023
 2024	 2025	 2028	 2030
 2031	 2239	 2240	 2242
 2249	 2250	 202411	

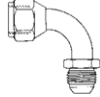
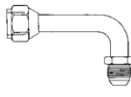
### JIC to JIC FITTINGS

 2020	 2027	 2033	 2039
 2041	 2043	 2070	 2071
 2406	 203101	 203102	 210292
 500454	 504095	 900599	

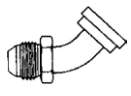
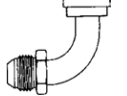
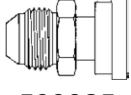

### CODE 61 to JIC

 500023	 500024
 500025	

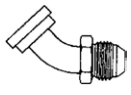
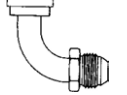
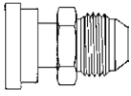

### CODE 62 to JIC

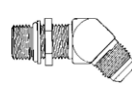
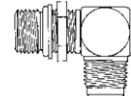
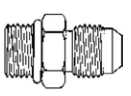
 ff5539	 ff5540
 ff5541	

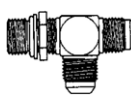
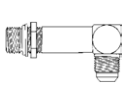
### ORB to JIC FITTINGS

 2061	 2062	 202702
 203003	 203005	 206209

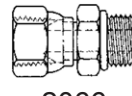
### NPT to ORB FITTINGS

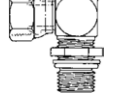
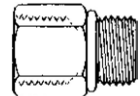
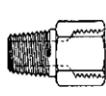
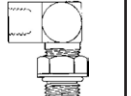
 2066	 2067	 2068
 2216	 2246	 206801

# CENTRAL HYDRAULICS INC.

•Daytona Beach •Cocoa •Leesburg •Ocala •Tampa 1-800-264-9571

## High Pressure Hydraulic Swivel Joints

### “S” Series/In-Line Swivel Joint

Sizes - ¼” through 2” pipe size

Connection types - JIC, pipe, SAE O-Ring face seal (male & female)

Operating pressures - vacuum & to 3,000 PSI

Operating temperatures - 40° to 200° F



### “9S” Series/90° Swivel Joint

Sizes - ¼” through 2” pipe size

Connection types - JIC & O-Ring (male), pipe and SAE O-Ring face seal

(male & female) & pipe union

Operating pressures - vacuum & to 3,000 PSI

Operating temperatures - 40° to 200° F



### “9SS” Series/Dual Plane Swivel Joint

Sizes - ¼” through 1¼” pipe size

Connection types - JIC & O-Ring (male), pipe & SAE

O-Ring face seal (male & female)

Operating Pressures - vacuum & to 3,000 PSI

Operating Temperatures - 40° to 200° F

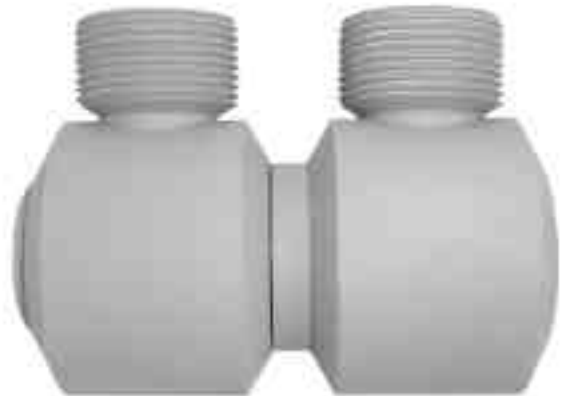

### “18S” Series/180° Swivel Joint

Sizes - ¼” through 2” pipe size

Connection types - JIC (male), pipe & SAE O-Ring face seal (male & female) & pipe union

Operating pressures - vacuum & to 3,000 PSI

Operating temperatures - 40° to 200° F





# CENTRAL HYDRAULICS INC.

•Daytona Beach •Cocoa •Leesburg •Ocala •Tampa 1-800-264-9571

## HYDRAULIC POWER UNITS

### Double-Power Unit

•M313-0147

#### Monarch M3551-0257

12v Power Up/Power Down Unit

2100#/1800# with Remote Control  
3gal Polytank

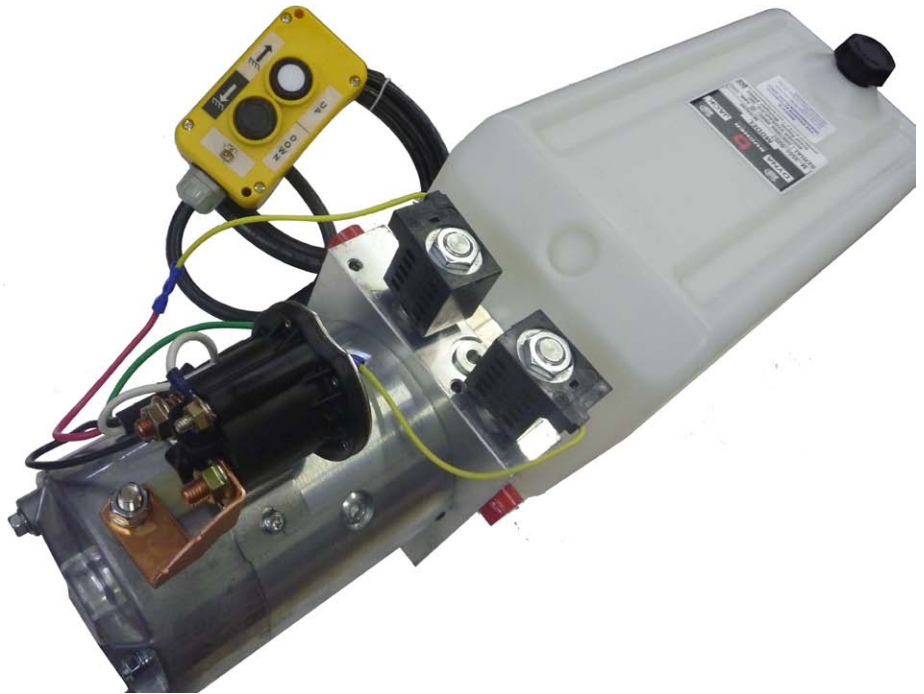

#### Monarch M313-0147

12v DC Manual Power-Up/Gravity Down

for Tommy Gate  
Small profile  
12v Tailgate Lift Power Unit



# CENTRAL HYDRAULICS INC.

•Daytona Beach •Cocoa •Leesburg •Ocala •Tampa 1-800-264-9571

## AC HYDRAULIC POWER UNITS

### Auto Hoist

•AC-10AH •AC-10FP-A

Power Up Button/  
Gravity Down Handle

#### AC-10AH 2-POST

230VAC 2hp 1ph Hoist 1.82gpm  
2750 psi 4gal verticle tank down

#### AC-10FP-A 4-POST

230VAC 3hp 1ph Hoist 2.82gpm  
2450 psi 6.3gal verticle tank down

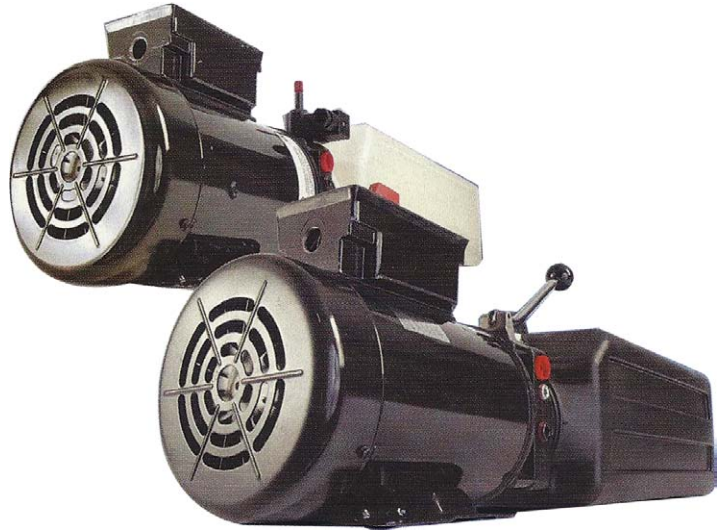

This power unit is designed specifically for use on 2 and 4 post auto hoists. This is for raise-hold-lower of the lift, with manual control of the lowering speed. A push-button, mounted on the unit, starts the motor to raise the lift. The unit features a fixed relief valve, so the lift cannot be overloaded, but (depending on cylinder size) can be used on most 7000 to 9000 lbs. capacity lifts.

**SPX** **STONE**

# CENTRAL HYDRAULICS INC.

•Daytona Beach •Cocoa •Leesburg •Ocala •Tampa 1-800-264-9571

## AC HYDRAULIC POWER UNITS

### Auto Hoist for Tire Changer

•AC-10TC

#### AC-10TC

115v AC 1PH Auto Hoist for Tire Changer  
Power Up/Gravity Down

3/4HP 115 VAC  
1.5 gal Tank is standard.  
Fixed relief set at 2300 psi.  
#6 ORB 9/16"-18 port  
.73 gpm

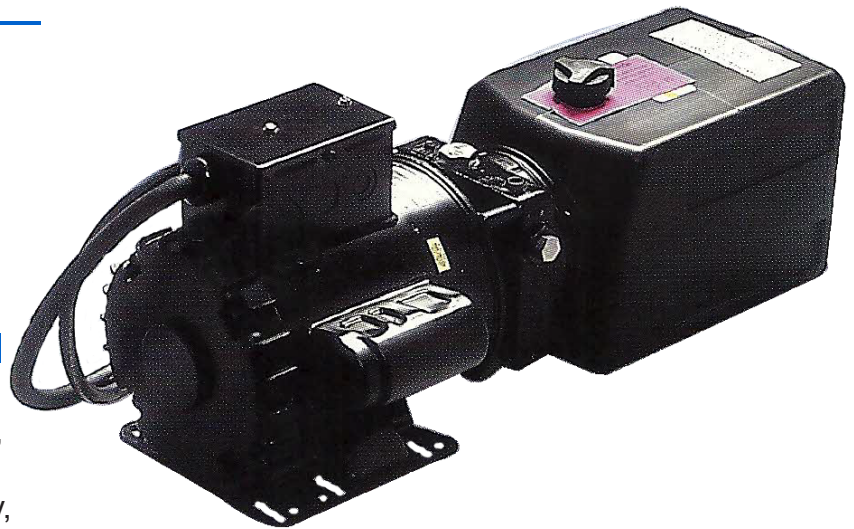

This power unit is designed for smaller, low-rise auto hoists and can be mounted either horizontally or vertically, operating on AC power. A push button on the motor starts the unit to raise the vehicle on the lift. To lower, a manually operated cartridge style release valve is used for fingertip control of lowering speed.



**SPX** **STONE**

# CENTRAL HYDRAULICS INC.

•Daytona Beach •Cocoa •Leesburg •Ocala •Tampa 1-800-264-9571

## DC HYDRAULIC POWER UNITS

### Dump Trailer •DC-41DTC



#### DC-41DTC-20-25P-25

12V DC Solenoid Operated  
Power Up/Power Down

2.5 gal Poly Tank is standard.  
High Pressure relief set at 2500lbs.  
Low Pressure relief set at 500lbs.  
Complete w/ Electric Controller.  
3/8" NPT Ports

This power unit is designed for use on a double acting dump trailer or dump bed application. Provides power lift-hold-power down operation. It can also be used to operate double-acting cylinder needs. All the Steel or Poly tank options are available in our stock.



**SPX** **STONE**

Fax: 386-257-5728 Tele. 1-800-264-9571 sales@centralhydraulics.com www.centralhydraulics.com

SPX-190-F-01

# CENTRAL HYDRAULICS INC.

•Daytona Beach •Cocoa •Leesburg •Ocala •Tampa 1-800-264-9571

## DC HYDRAULIC POWER UNITS

•Tail Gate •Truck Mounted Crane •Dump Truck  
•DC-20SF

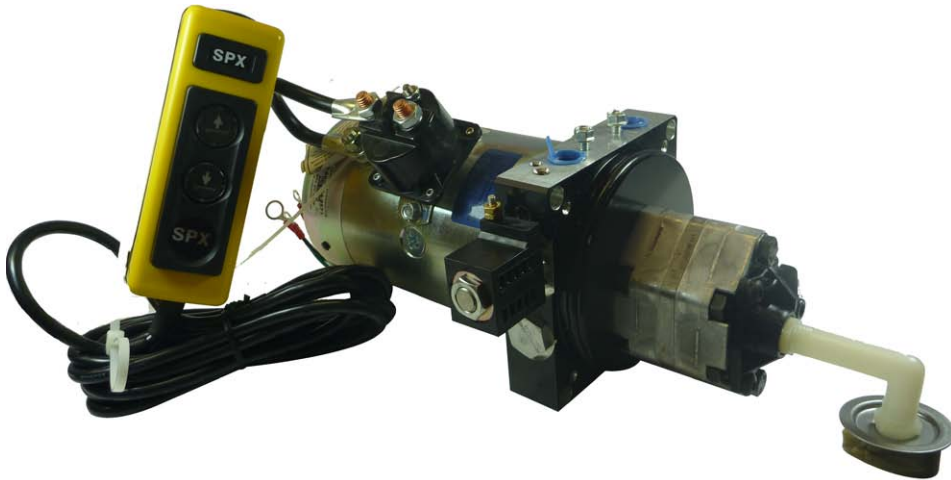

### DC-20SF (Base Unit)

12v DC Solenoid Operated  
Power Up/Gravity Down

Controller Included  
Adj. Relief set at 2500lbs.  
3/8" NPT Ports  
Tank Sold seperately

The most common, rugged and reliable piece of truck equipment is the tail gate. The original Stone unit, now manufactured by SPX Fluid Power, has been used by manufacturers of this equipment since the industry began. Our 12V and 24V DC power packs come in manual or solenoid-operated versions for basic power up/gravity down tail gates. Power packs also available for cantilever and tuck-away designs of tail gates. Two button hand control is available for many DC lift/hold/lower applications. Various steel or poly tank sizes can be supplied to suit hydraulic cylinder capacities.



**SPX** **STONE**

# CENTRAL HYDRAULICS INC.

•Daytona Beach •Cocoa •Leesburg •Ocala •Tampa 1-800-264-9571

## DC HYDRAULIC POWER UNITS

### Auxiliary Power Unit •DC-30APU

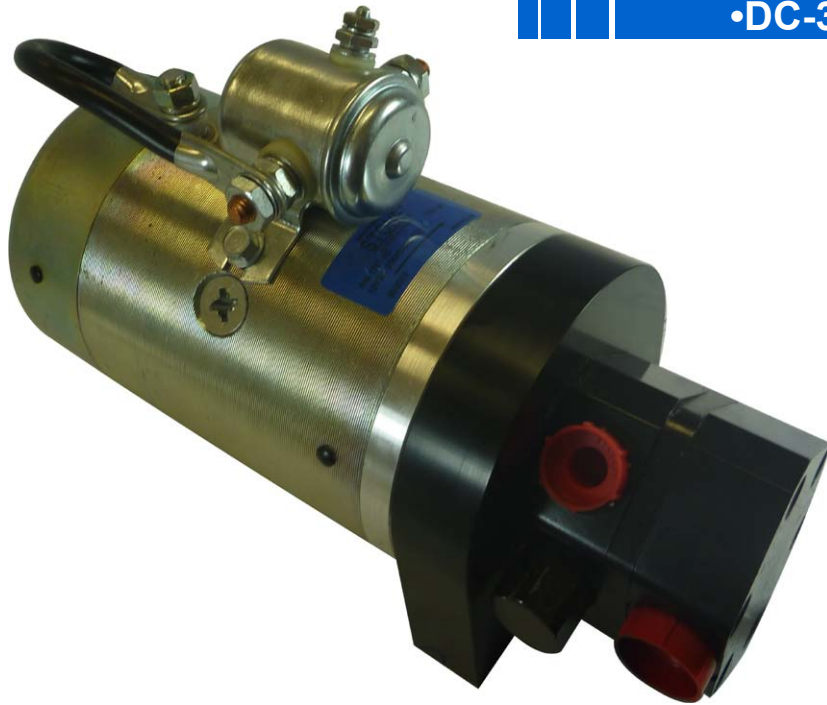

#### DC-30APU

12v DC 1T Std. Duty

Check and Adj. Relief set at 2500psi

3/4" SAE Side Inlet

9/16" SAE Side Outlet and Relief  
Drain Ports

2.2 gpm @ 500 psi

1.7 gpm @ 1000 psi

1.4 gpm @ 2000 psi

The power unit is intended to be used with remote directional control valving and reservoir. This unit has an adjustable relief valve and outlet check valve. They are designed for applications such as backup (auxiliary) hydraulic power for truck mounted or the other mobile equipment, including emergency power steering for off-highway vehicles, elevated platforms, aerial buckets and manlifts. It can also be used to power material handling functions and other intermittent duty applications.











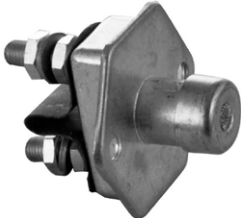

# CENTRAL HYDRAULICS INC.

•Daytona Beach •Cocoa •Leesburg •Ocala •Tampa 1-800-264-9571

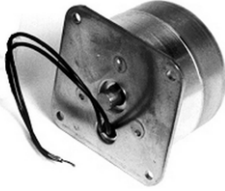
## Power Units

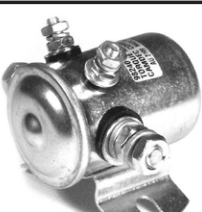
### Switches and Solenoids

	<b>APL2250</b> Push Button Start Switch	<b>APL3020</b> V3 Post Positive grounded Prestolite Solenoid	
	<b>APL2252</b> Canister Switch, Jam-type mount	<b>APL3051</b> Smart Start Solenoid SPX EF-1070	
	<b>APL3000</b> 3 post, positive to excite, grounded solenoid with flat base.	<b>APL3094</b> 3 Post positive grounded solenoid Maxon	
	<b>APL3004</b> 4 post insulated solenoid with flat base	<b>APL3390</b> Drain Solenoid	
	<b>APL3010</b> 3 post, positive to excite, grounded solenoid with curved base	<b>BPL2250</b> Monarch Canister Switch Screw-type	
	<b>APL3014</b> 4 post insulated solenoid with curved base	<b>BPL2254</b> Canister Switch for Condenser Valve	
		<b>BPL3000</b> 3 post, negative to excite, insulated solenoid with flat base	

# CENTRAL HYDRAULICS INC.

•Daytona Beach •Cocoa •Leesburg •Ocala •Tampa 1-800-264-9571

## RESERVOIRS

### TRANSITION STYLE STEEL 6.7"/170MM

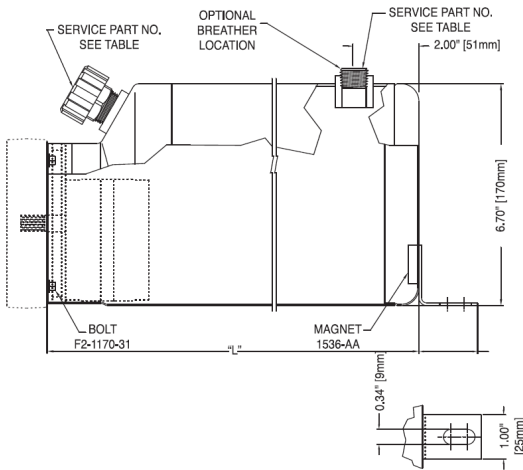

Kit #	Gallons	Length (in)	Useable Oil Capacity		Breather Part #	Plug Part #
			Vertical (ci)	Horizontal (ci)		
KR40	1.0	7.88	100	170	1214-AA	1465-AA
KR45	1.2	9.84	160	220	1214-AA	1465-AA
KR41	1.5	11.81	220	270	1683-AB	1896-AA
KR42	2.0	15.75	340	360	1683-AB	1896-AA
KR46	2.5	17.00	380	390	1683-AB	1896-AA
KR43	3.0	21.65	520	500	1683-AB	1896-AA
KR44	4.0	26.00	650	600	1683-AB	1896-AA

Foot included on 1.5 gallon and larger.

### ROUND STEEL 4.75"/120MM

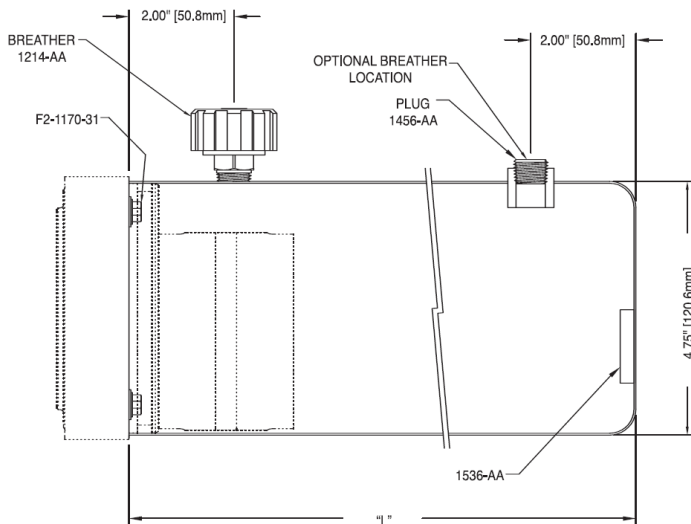

Kit #	Quarts	Length (in)	Useable Oil Capacity	
			Vertical (ci)	Horizontal (ci)
KR12	2	8.5	85	90
KR14	3	12.00	138	135
KR15	4	14.50	165	161





# CENTRAL HYDRAULICS INC.

•Daytona Beach •Cocoa •Leesburg •Ocala •Tampa 1-800-264-9571

## RESERVOIRS

### OFFSET PLASTIC 6.7"/170MM

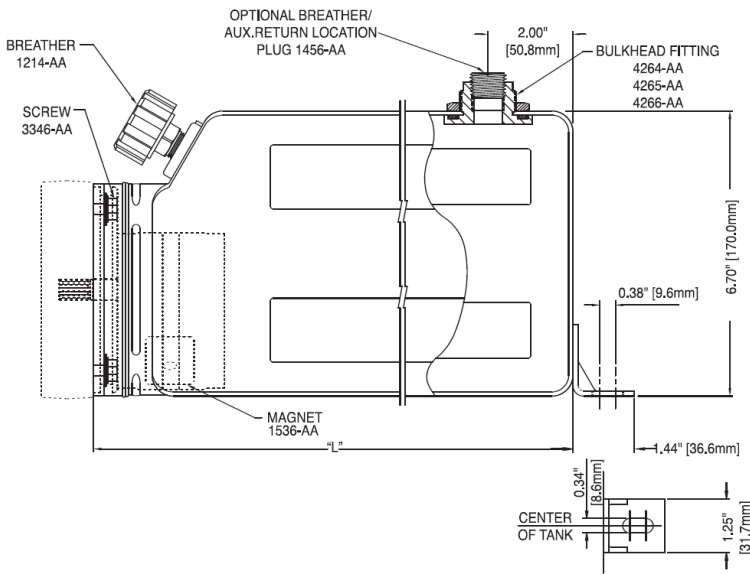

Kit #	Gallons	Length (in)	Useable Oil Capacity	
			Vertical (ci)	Horizontal (ci)
KR50	1.0	7.50	120	186
KR55	1.2	9.00	180	230
KR51	1.5	11.00	260	286
KR52	2.0	13.00	340	345
KR56	2.5	15.00	420	400
KR53	3.0	20.00	620	540
KR54	4.0	26.00	860	715

Foot included on 1.5 gallon and larger.

### SQUARE PLASTIC 5.0"/127MM

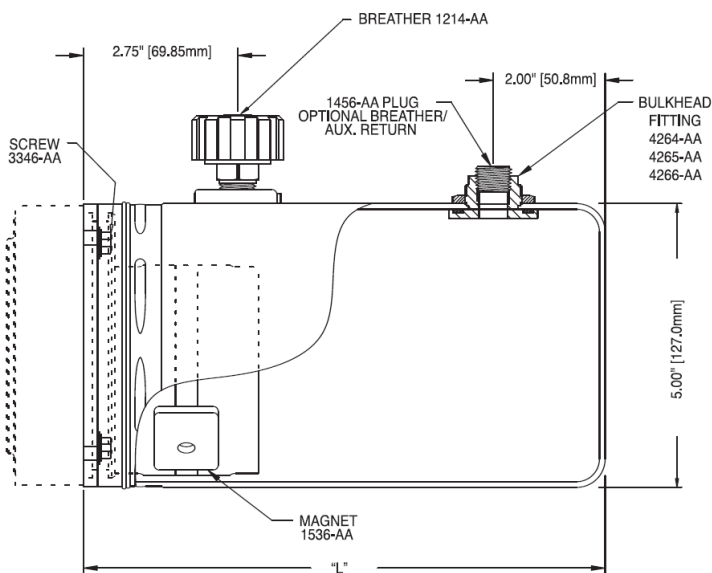

Kit #	Quarts	Length (in)	Useable Oil Capacity	
			Vertical (ci)	Horizontal (ci)
KR22	2	8.5	83	100
KR24	3	11.00	138	130
KR25	4	14.00	200	175

**SPX STONE**

# CENTRAL HYDRAULICS INC.

•Daytona Beach •Cocoa •Leesburg •Ocala •Tampa 1-800-264-9571

## PNEUMATIC Quick Disconnects



*The Right Connection™*



# CENTRAL HYDRAULICS INC.

•Daytona Beach •Cocoa •Leesburg •Ocala •Tampa 1-800-264-9571



# CENTRAL HYDRAULICS INC.

•Daytona Beach •Cocoa •Leesburg •Ocala •Tampa 1-800-264-9571



## Hydraulic Live Swivels

5000 psi



## Inline & 90° Swivels

Heavy Duty Ball Bearing, Rebuildable Design

---

Central Hydraulics Inc.

1-800-264-9517

[www.CentralHydraulics.com](http://www.CentralHydraulics.com)

# **CENTRAL HYDRAULICS INC.**

•Daytona Beach •Cocoa •Leesburg •Ocala •Tampa **1-800-264-9571**

---

## **Flexmaster**

---

# **1-800-264-9571**



**Eaton Aeroquip  
Flexmaster Pipe and Tube Couplers  
In Stock at the best prices available.**

# CENTRAL HYDRAULICS INC.

•Daytona Beach •Cocoa •Leesburg •Ocala •Tampa 1-800-264-9571

## Directional Control Valves

# YUKEN



12v - 24v - 110v - 220v  
D01 - D03 - D05 - etc...

**We can interchange**  
Vickers, Parker, Rexroth,  
Nachi, etc..

# Daman

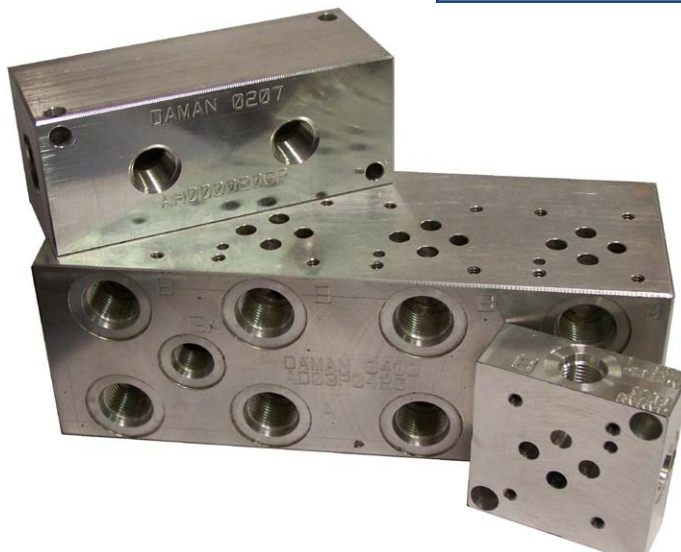

Subplates,  
manifolds,  
and header  
blocks

# CENTRAL HYDRAULICS INC.

•Daytona Beach •Cocoa •Leesburg •Ocala •Tampa 1-800-264-9571

## Spin-On Hydraulic Filters



Donaldson®  
Filtration Solutions

### 3/4" NPT

Flow Range to  
30gpm.  
Up to 150psi



[P561131](#)

Single Filter Head

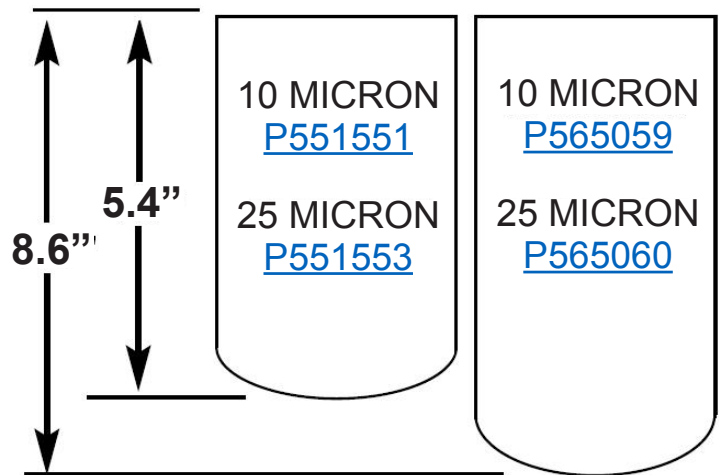

[P563298](#)



Color-Coded  
0-100psi  
Gage

### 1 1/4" NPT

Flow Range to  
60gpm.  
Up to 150psi



[P563268](#)

Single Filter Head

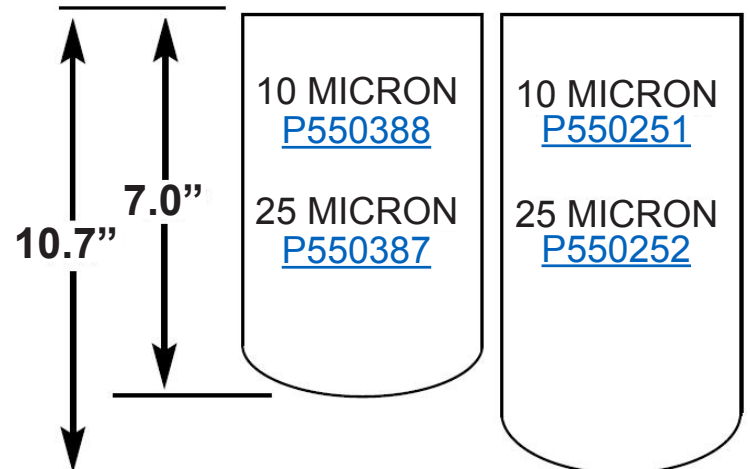

# CENTRAL HYDRAULICS INC.

•Daytona Beach •Cocoa •Leesburg •Ocala •Tampa 1-800-264-9571

## Spin-On Filters



### 1-1/2" NPT Head P563274

Part #	Micron Rating
P550388	10 Micron
P550387	25 Micron
P550251	10 Micron Long Element
P550252	25 Micron Long Element

<b>Working Pressures to:</b>	150 psi
<b>Rated Static Burst to:</b>	250 psi
<b>Flow Range to:</b>	100 gpm

## Features

SP80/90 double element head allows for double the flow capacity, with two filters to hold more contaminant. Aluminum casting and Buna-N seals standard.

### Beta Rating

- Performance to  $\beta_{6(c)} = 1000$

### Porting Sizes

- 1½" NPT, 2" SAE Flange, SAE-24

### Porting Sizes

- 6.7"
- 7.0"
- 10.7"

### Standard Bypass Ratings

- 25 psi
- 15 psi
- 5 psi
- No Bypass

### Operating Temperatures

- -22°F to 250°F / -30°C to 121°C

### Assembly Weight

- 10.0 lbs (short)
- 11.8 lbs (long)



# CENTRAL HYDRAULICS INC.

•Daytona Beach •Cocoa •Leesburg •Ocala •Tampa 1-800-264-9571

## Low to Medium Pressure Filters

**Working Pressure: 500 psi**

**Rated Static Burst to: 1000 psi**

**Flow Range to:** HMK04 HMK24  
35 gpm 60 gpm

**Porting Sizes:** HMK04 HMK24  
SAE-16 O-Ring SAE-20 O-Ring

**Replacement Filter Lengths: 6" and 8.12"**

**Standard Bypass Rating: 25psi, 50psi, No Bypass**

**Operating Temperatures: -20°F to 250°F**

### Features

HMK04 (single) and HMK24 (double) Duramax® spin-on filters both feature a die-cast aluminum head, a heavyduty steel body, with diecast aluminum top plate for added strength. A special head-to-canister O-Ring seal prevents leakage. BunaN seals are standard; Viton® seals are available on some models.

Since both HMK04 and HMK24 models use the same replacement filter elements, they make a great team for your application. Both filters feature identical pressure ratings, but HMK24 handles double the flow capacity as HMK04, so there's no need to inventory two different part numbers for replacement elements.

A full range of media options are available, using Donaldson's exclusive **Synteq®** synthetic media designed especially for liquid filtration. Likewise, select the exact indicator types and bypass options to suit your application.

**Working Pressure: 1000 psi**

**Rated Static Burst to: 2000 psi**

**Flow Range to: 25 gpm**

**Porting Sizes: 3/4" SAE O-Ring (standard)**

**Replacement Filter Lengths: 5.5" and 9.5"**

**Standard Bypass Rating: 50psi or No Bypass**

**Operating Temperatures: -20°F to 250°F**

### Features

HMK03 Series Duramax® spin-on filters offer twice the capacity of competitive filters, yet they are physically smaller than traditional housing/cartridge filter assemblies. It features a die cast aluminum head and a unique radial seal O-Ring gasket design that eliminates leakage.

Take advantage of Donaldson's Mix 'n Match system of in-stock heads, housings and media choices—so you can get exactly what you need.



HMK03

# CENTRAL HYDRAULICS INC.

•Daytona Beach •Cocoa •Leesburg •Ocala •Tampa 1-800-264-9571

## High Pressure Filters

**Working Pressure: 2000 psi**

**Rated Static Burst to: 4500 psi**

**Flow Range to: 20 gpm**

**T-Type Porting Sizes: SAE-12 O-Ring**

**Replacement Filter Lengths: 4.37" and 8.12"**

**Standard Bypass Rating: 50psi / No Bypass**

**Operating Temperatures: -20°F to 250°F**



HPK02

Housing  
P167452

Head  
P163681

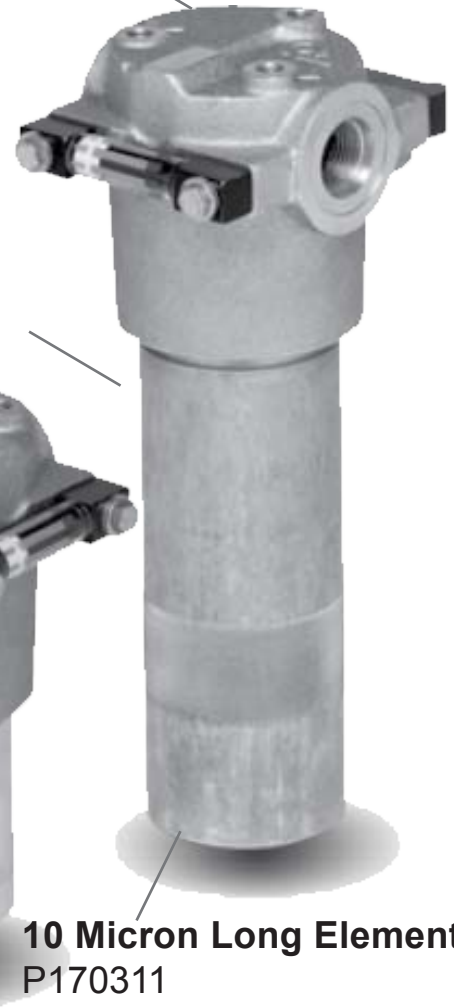

10 Micron Long Element  
P170311

The HPK02 is a heavy-duty filter built for high pressure applications, with cast aluminum head and impact-extruded aluminum housing for strength and durability at relatively light weight.

Take advantage of our Mix 'n Match system of in-stock heads, housings and cartridges—so you can get exactly what you need! HPK02 is available with your choice of visual or AC/DC electrical indicators. Likewise, choose the bypass option that's right for your application—50 psi bypass, or no bypass. Seals made of fluorocarbon (such as Viton® and Fluorel®) or BunaN are available with HPK02.

All HPK02 filters contain Synteq®, our synthetic filter media designed especially for liquid filtration.

# CENTRAL HYDRAULICS INC.

•Daytona Beach •Cocoa •Leesburg •Ocala •Tampa 1-800-264-9571

## Suction Strainers



Donaldson

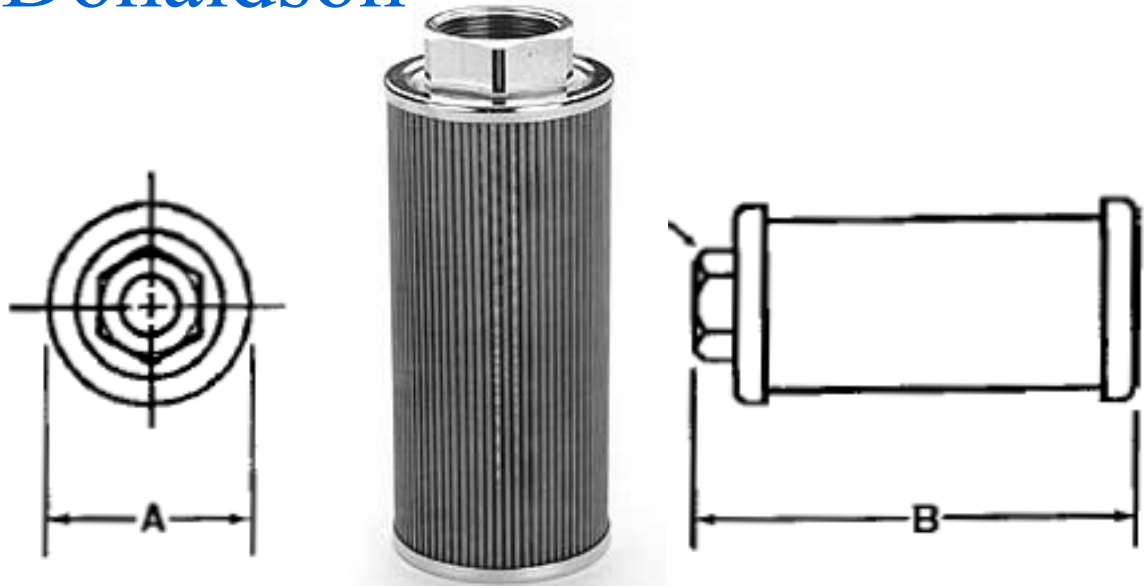

Part #	NPT Size	Dim. A	Dim. B	Max. Flow
P169013	3/4"	2.63	3.55	8
P169014	1"	2.63	5.35	10
P169015	1-1/4"	3.38	6.85	20
P169016	1-1/2"	3.38	8.01	30
P169017	1-1/2"	3.94	9.80	50
P169018	2"	3.94	9.80	50
P169019	2-1/2"	5.12	10.10	75
P169020	3"	5.12	11.78	100

### Many other sizes available!

Donaldson suction strainers are zinc-plated, with stainless steel mesh screens and rugged steel core centers epoxy bonded to heavy gauge connector and end caps. Suction strainers filter petroleum-based hydraulic fluids, phosphate esters, waters glycols, lubricating oils, coolants, fuels and water in fluid reservoirs, sumps and similar applications. They are cleanable and reusable. Clean by swishing in non-caustic solvent, then blow dry from inner diameter to outer diameter with compressed air.

# CENTRAL HYDRAULICS INC.

•Daytona Beach •Cocoa •Leesburg •Ocala •Tampa 1-800-264-9571

## Donaldson Filter Spreadsheet

Pressure	Thread	MAX Flow	Head	Hi-Pressure Housing	Micron	Standard Element	Long Element	Series
SUCTION	3/4"NPT	20 GPM	P561132		150 MESH	P550274		
SUCTION	1-1/4"NPT	40 GPM	P563491		150 MESH	P550275	P550276	SP50/60
150 PSI	3/4"NPT	30 GPM	P561131		10M	P551551	P565059	LPS04
					25M	P551553	P565060	
150 PSI	1-1/4"NPT	40 GPM	P563268		10M	P550388	P550251	SP50/60
					25M	P550387	P550252	
150 PSI	1-1/2"NPT	90 GPM	P563274		10M	P550388	P550251	SP80/90
			DUALFILTER		25M	P550387	P550252	
500 PSI	#16 ORB	35 GPM	P163681		10M		P176566	HMK04
	#24 ORB	60 GPM	P179609		20M	P164375		
					33M		P164384	
1000 PSI	#12 ORB	25 GPM	P170773		20M	P170310	P170311	HMK03
2000 PSI	#12 ORB	20 GPM	P167728	P167452	9M		P165043	HPK02
3000 PSI	#16 ORB	60 GPM	P166353	P179579	10M	P164166		HPK03
6000 PSI	Split Flange Code 62	100 GPM	P170057	P162451	10M	P164166		HPK04

# CENTRAL HYDRAULICS INC.

•Daytona Beach •Cocoa •Leesburg •Ocala •Tampa 1-800-264-9571

## Gear Pump Formulas

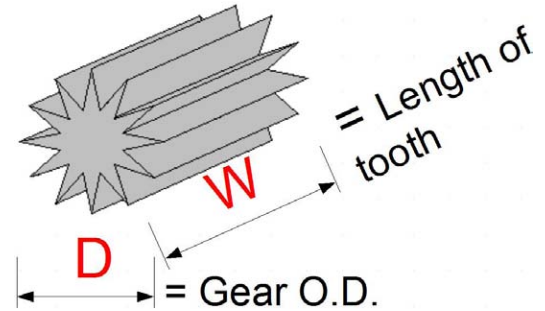
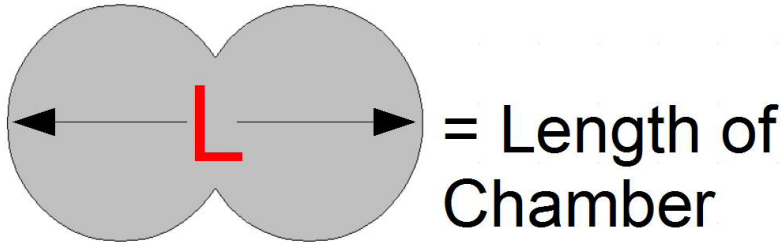

To calculate the GPM at 1800rpm by measurements of the pump.

$$47 \times W \times (2D - L) \times \frac{(L - D)}{2}$$

To calculate the cubic inch displacement if you have GPM & speed.

$$\frac{\text{GPM} \times 231}{\text{Speed}} = \text{Cubic Inch}$$

To calculate the GPM if you know displacement & speed.

$$\frac{\text{Cubic inch} \times \text{Speed}}{231} = \text{GPM}$$

To calculate the HP if you know the torque and speed of the motor.

$$\frac{\text{Inch lbs of torque} \times \text{RPM}}{63024} = \text{HP}$$

To calculate the HP required if you know the pressure and GPM of the pump.

$$\frac{\text{Pressure} \times \text{RPM}}{1714} = \text{HP Required to drive the pump}$$

\*Good rule of thumb\*

Allow for: 3/4hp per 1 gal. @ 1000psi  
 1-1/2hp per 1 gal. @ 2000psi  
 2hp per 1 gal. @ 3000psi

\*Fact\*

231 ci = 1 gal

# CENTRAL HYDRAULICS INC.

•Daytona Beach •Cocoa •Leesburg •Ocala •Tampa 1-800-264-9571

## White Drive Products

### WD (145)



WD motors have a smaller outline yet still provide high efficiency across a wide performance range and an economical solution for medium duty applications.

Typical applications include agriculture, conveyors, carwashes, sweepers and food processing.

**Displacement** - 1.5 - 23.5 in/rev  
**Max. Speed** - 1361 RPM  
**Max. Pressure** - 2000 psi  
**Max. Torque** - 4248 lb-in  
**Max. Flow** - 16 gpm

### WP (155)



WP motors deliver significant power in a compact package, important where application space is at a premium and torque cannot be sacrificed.

Typical applications include grain augers, spreaders, hay rakes, carwashes, combines and food processing.

**Displacement** - 1.5 - 24.4 in/rev  
**Max. Speed** - 1570 RPM  
**Max. Pressure** - 2320 psi  
**Max. Torque** - 4248 lb-in  
**Max. Flow** - 16 gpm



### RS (200)



WR motors are an upgrade to the RS motor used in light to medium duty applications and delivers greater performance in pressure, speed, and torque. Integral check valves offer improved seal life.

Typical applications include lightweight wheel drives, positioners, conveyors, swing drives, feed rollers, screw drives and spinners.

**Displacement** - 2.5 - 23.5 in/rev  
**Max. Speed** - 1110 RPM  
**Max. Pressure** - 2500 psi  
**Max. Torque** - 4873 lb-in  
**Max. Flow** - 16 gpm

### WR (255)



WR motors are an upgrade to the RS motor used in light to medium duty applications and delivers greater performance in pressure, speed, and torque. Integral check valves offer improved seal life.

Typical applications include lightweight wheel drives, positioners, conveyors, swing drives, feed rollers, screw drives and spinners.

**Displacement** - 2.5 - 23.5 in/rev  
**Max. Speed** - 1110 RPM  
**Max. Pressure** - 2500 psi  
**Max. Torque** - 4873 lb-in  
**Max. Flow** - 16 gpm

# CENTRAL HYDRAULICS INC.

•Daytona Beach •Cocoa •Leesburg •Ocala •Tampa 1-800-264-9571

## White Drive Products

### HK (315)



HK motor/brakes are a performance matched brake package utilizing BK brake and HB motor technologies.

The result is a proven, compact, intergrated package suitable for applications needing holding capability up to 10,000 lb-in along with smooth efficient drive motor performance.

**Displacement** - 3.2 - 24.9 in/rev  
**Max. Speed** - 700 RPM  
**Max. Pressure** - 3000 psi  
**Max. Torque** - 8400 lb-in  
**Max. Flow** - 20 gpm

### CE (400, 410, 420, 430)



CE motors are 10-25% lighter and more compact than comparable designs, providing the perfect solution for medium duty applications with space restrictions.

Typical applications include medium duty wheel drives, grapple heads, feed rollers and broom drives.

**Displacement** - 7.4 - 45.6 in/rev  
**Max. Speed** - 370 RPM  
**Max. Pressure** - 3000 psi  
**Max. Torque** - 9575 lb-in  
**Max. Flow** - 20 gpm



### WG (275, 277, 280)



WG motors incorporated a needle bearing to provide and espically solid platform for any medium duty application where side load ay present a concern.

Typical application include light to medium duty wheel drives, feed rollers, augers, brush drives and conveyors.

**Displacement** - 2.5 - 24.4 in/rev  
**Max. Speed** - 830 RPM  
**Max. Pressure** - 2000 psi  
**Max. Torque** - 4850 lb-in  
**Max. Flow** - 15 gpm

### HB (300, 310, 320)



HB motors are designed for applications requiring peak efficiency in continuous operation, while providing high performance at low flow rates.

Typical applications include medium duty wheel drives, spinners, chippers, broom drives, auger and machine tool indexers.

**Displacement** - 3.2 - 24.9 in/rev  
**Max. Speed** - 700 RPM  
**Max. Pressure** - 3000 psi  
**Max. Torque** - 8400 lb-in  
**Max. Flow** - 20 gpm

# CENTRAL HYDRAULICS INC.

•Daytona Beach •Cocoa •Leesburg •Ocala •Tampa 1-800-264-9571

## White Drive Products

### DT

(700, 701, 710, 740)



DT motors provides tremendous torque for medium to heavy duty applications. Heavy duty shaft bearings allow high load carrying capabilities, while many shaft options provide solutions for a wide variety of applications.

Typical applications include heavy duty wheel drives, concrete mixing machines, pumping units, conveyors, boring machines and rotators.

**Displacement** - 18.3 - 127.7 in/rev  
**Max. Speed** - 320 RPM  
**Max. Pressure** - 3000 psi  
**Max. Torque** - 23550 lb-in  
**Max. Flow** - 25 gpm

### WS

(350, 355, 357)



WS motors feature a robust design for medium duty applications and high flow rates--a three zone commutator valve for higher flow capacity; heavy duty tapered roller bearings for increased side load; and a larger drive link to better withstand pressure and torque spikes.

Typical applications include skid steer attachments, augers, mowers, and harvesting equipment.

**Displacement** - 4.8 - 30.3 in/rev  
**Max. Speed** - 870 RPM  
**Max. Pressure** - 3000 psi  
**Max. Torque** - 7295 lb-in  
**Max. Flow** - 20 gpm

### RE

(500, 510, 520, 530, 540)



RE motors provide excellent value for medium to heavy duty applications. The patented balance plate design assures high volumetric efficiency at start-up and high torque in running conditions.

Typical applications include medium duty wheel drives, mixers, augers, grapple heads, winch drives, swing drives and broom drives

**Displacement** - 7.4 - 45.6 in/rev  
**Max. Speed** - 370 RPM  
**Max. Pressure** - 3000 psi  
**Max. Torque** - 9700 lb-in  
**Max. Flow** - 20 gpm

### DR

(600, 610, 620, 630, 640)



HB motors are designed for applications requiring peak efficiency in continuous operation, while providing high performance at low flow rates.

Typical applications include medium duty wheel drives, spinners, chippers, broom drives, auger and machine tool indexers.

**Displacement** - 12.4 - 45.6 in/rev  
**Max. Speed** - 470 RPM  
**Max. Pressure** - 3000 psi  
**Max. Torque** - 9800 lb-in  
**Max. Flow** - 25 gpm



# CENTRAL HYDRAULICS INC.

•Daytona Beach •Cocoa •Leesburg •Ocala •Tampa 1-800-264-9571

## White Drive Products

### BK

(910, 914)



BK brakes provide up to 10,000 lb-in. of holding torque. This compact spring-applied, hydraulically released brake eliminates the cables, linkages, cylinders and brackets used in other brake systems, providing a simpler, more cost-effective solution.

Typical applications include wheel drives, positioners, conveyors, door openers and swing drives.

**Max. Speed** - 870 RPM

**Release Pressure** - 400 psi

**Max. Rel. Pressure** - 3000 psi

**Release Volume** - 0.7 cu.in.

### D9

(800)



D9 motors are the strongest in the product line, ruggedly constructed and able to operate in extreme conditions in a variety of applications, offering higher flow capabilities and greater axial and radial load capacities.

Typical applications include construction machinery, agricultural machinery and associated attachments.

**Displacement** - 15.6 - 62.7 in<sup>3</sup>/rev

**Max. Speed** - 370 RPM

**Max. Pressure** - 3000 psi

**Max. Torque** - 9575 lb-in

**Max. Flow** - 20 gpm

### SB

(930)



SB brakes feature a multiple-wet-disc design for superior performance in an extremely compact package, providing a holding capacity in excess of 5,500 lb-in.

SB brakes are easily mated to a variety of global industry standard motor mounting and shaft options, and can be used as a stand-alone brake without an input drive motor

### FD

(950)



The FD flow divider is the most accurate available. Our patented Roller Stator design reduces internal leakage and friction, resulting in higher efficiency and providing more accurate output flows and quieter operation.

Typical applications include cylinder synchronization, parallel motor circuits and pressure intensification

**Holding Torque** - 2000-5000 lb-in

**Release Volume** - 0.51 cu.in.

**Release Pressure** - 290 psi

**Max. Rel. Pressure** - 3625 psi

**Flow** - 2 -40 gpm

**Max. Pressure** - 3000 psi

**Max. Pressure Differential Between Ports** - 2500 psi

# CENTRAL HYDRAULICS INC.

•Daytona Beach •Cocoa •Leesburg •Ocala •Tampa 1-800-264-9571

## Dump Pumps and Accessories

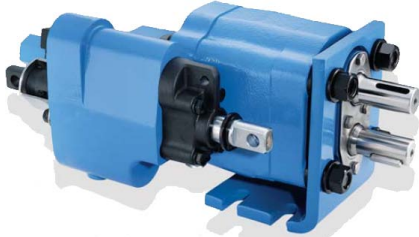

Pump/valve assembly for heavy and medium duty dump trucks and dump trailers



**DMD-25 (C102)**

**DM-640 (C101)**

Central Hydraulic Series	IN	GPM/900 rpm/ 2000 psi	GPM/1500 rpm/ 2000 PSI	GPM/1500rpm / 2000 psi
DM-640-25/DMD-25	6.4	21.0	29.0	37.5

**Permco Dump Pump Features** • Direct mount SAE “B” 4 bolt or twin shafted remote mount with bracket (DM-640) or built-in mounting bracket (DMR-400) • Manual shift, “OEM” air shift (DM-640 and DMD-25 only), or after market air shift, each with full metering capabilities • 100% factory tested • Heavy duty “controlled stress” roller bearings • Pump and cylinder protected in the raise and neutral position of the spool • 2 or 3 line configurations available • 2 extended studs for easy installation of pump support bracket on direct mount (DMD-20 and DMD-25 only) • Built-in load check maintains dump body angle and is installed in the cylinder port for superior self-cleaning • Built-in direct acting relief valve set at factory • Neutral lock-out safety cap for use with pull-out cable • High strength alloy steel gear and shaft set



**DMD-400**

Pump/valve assembly for heavy and medium duty dump trucks and dump trailers



**DMR-400**

Central Hydraulic Series	IN	GPM/900 rpm/ 2000 psi	GPM/1500 rpm/ 2000 PSI	GPM/1500rpm / 2000 psi
DMR/DMD-300	3.0	10.0	14.0	17.5
DMR/D,D-400	4.0	13.5	19.0	24.0

The **PRM P1229** air valve controls both the Dump Pump and the PTO in one lever. There are options for detent of the lever controlling the pump and a PTO kickout.



The APS C-3505-DM is an air shift cylinder that fits the DMD-25 and DM-640 Dump Pump as well as all other units of similar design.



# CENTRAL HYDRAULICS INC.

•Daytona Beach •Cocoa •Leesburg •Ocala •Tampa 1-800-264-9571

## Hydraulic Gear Pump

### CGP CBN 1/2" Shaft HI/LO Log Splitter Pump 1.78" Pilot



**Model GP-CBN** is a HI/LO Hydraulic Gear Pump with 12 displacement combinations with maximum pressures of 900 psi for the low pressure pump and 3000 psi for the high pressure pump. The change from LO to HI pressure is automatic with the LO side pressure pre set from 400 psi to 900 psi. The HI/LO pump is all cast Iron.

Applications for the HI/LO pump are log splitters, presses etc. where rapid movement of the cylinder at low pressure is required prior to automatically switching to the high pressure mode to meet load requirements.

Part #	Displ. cu.in/rev		Pressure		MAX RPM	MAX GPM@ 3600	Req. HP@ 3600	Ports
	LO pressure	HI pressure	LO	HI				
CBN080	0.384	0.128	400/900	3000	3600	8	5	INLET Barb 1"  OUTLET NPT 1/2"
CBN105	0.537	0.183	400/900	3000	3600	10.5	6	
CBN110	0.537	0.189	400/900	3000	3600	11	8	
CBN130	0.646	0.189	400/900	3000	3600	13	8	
CBN160	0.775	0.256	400/900	3000	3600	16	10	

# CENTRAL HYDRAULICS INC.

•Daytona Beach •Cocoa •Leesburg •Ocala •Tampa 1-800-264-9571

## Hydraulic Gear Pump



### **CGP CBN 5/8" Shaft HI / LO Log Splitter Pump 2 Bolt "A" 3.25" Pilot**

**Model GP-CBN** is a HI/LO Hydraulic Gear Pump offers maximum pressures of 900 psi for the low pressure pump and 3000 psi for the high pressure pump. The change from LO to HI pressure is automatic with the LO side pressure pre set from 400 psi to 900 psi. The HI/LO section of the pump is all cast Iron. The standard mounting flange is SAE A - 2 bolt. Applications for the HI/LO pump are log splitters, presses etc. where rapid movement of the cylinder at low pressure is required prior to automatically switching to the high pressure mode to meet load requirements.

Part #	Displ. cu.in/rev		Pressure		MAX RPM	MAX GPM@ 3600	Ports
	LO pressure	HI pressure	LO	HI			
CBN220	0.464	0.93	400/ 900	3000	3600	22	INLET NPT 1"
CBN280	0.464	1.397	400/ 900	3000	3600	28	OUTLET NPT 3/4"

# CENTRAL HYDRAULICS INC.

•Daytona Beach •Cocoa •Leesburg •Ocala •Tampa 1-800-264-9571

## Hydraulic Gear Pump



Model GP-F20 offers aluminium body and cast Iron end plate construction, high pressure Hydraulic Gear Pump with 11 displacement sizes from 0.24 to 1.95 cu.in/rev.

### F20 - 5/8" 9 TOOTH SPLINE SHAFT SAE A - 2 Bolt Flange Mount

PART #	cu.in/ rev	Rotation	MAX psi	MAX RPM	GPM@ 1800rpm	SAE Ports
GP-F20-04-S9-A	0.24	C.C.W.	3650	3600	1.87	<b>INLET</b> #12 ORB 1-1/16"-12  <b>OUTLET</b> #10 ORB 7/8"-14
GP-F20-04-S9-C	0.24	C.W.	3650	3600	1.87	
GP-F20-06-S9-A	0.36	C.C.W.	3650	3600	2.81	
GP-F20-06-S9-C	0.36	C.W.	3650	3600	2.81	
GP-F20-08-S9-A	0.48	C.C.W.	3650	3600	3.74	
GP-F20-08-S9-C	0.48	C.W.	3650	3600	3.74	
GP-F20-10-S9-A	0.61	C.C.W.	3650	3600	4.75	
GP-F20-10-S9-C	0.61	C.W.	3650	3600	4.75	
GP-F20-12-S9-A	0.73	C.C.W.	3650	3600	5.69	
GP-F20-12-S9-C	0.73	C.W.	3650	3600	5.69	
GP-F20-14-S9-A	0.85	C.C.W.	3650	3600	6.62	
GP-F20-14-S9-C	0.85	C.W.	3650	3600	6.62	
GP-F20-16-S9-A	0.97	C.C.W.	2900	3600	7.56	
GP-F20-16-S9-C	0.97	C.W.	2900	3600	7.56	
GP-F20-20-S9-A	1.22	C.C.W.	2900	3600	9.51	
GP-F20-20-S9-C	1.22	C.W.	2900	3600	9.51	
GP-F20-25-S9-A	1.52	C.C.W.	2900	3600	11.84	
GP-F20-25-S9-C	1.52	C.W.	2900	3600	11.84	
GP-F20-30-S9-A	1.83	C.C.W.	2300	3600	14.26	<b>INLET</b> #16 ORB 1-5/16"-12 <b>OUTLET</b> #12 ORB 1-1/16"-12
GP-F20-30-S9-C	1.83	C.W.	2300	3600	14.26	
GP-F20-32-S9-A	1.95	C.C.W.	2300	3600	15.20	
GP-F20-32-S9-C	1.95	C.W.	2300	3600	15.20	

# CENTRAL HYDRAULICS INC.

•Daytona Beach •Cocoa •Leesburg •Ocala •Tampa 1-800-264-9571

## Hydraulic Gear Pump

**Model GP-F20** offers aluminium body and cast Iron end plate construction, high pressure Hydraulic Gear Pump with 11 displacement sizes from 0.24 to 1.95 cu.in/rev.



### F20 - 5/8" KEYED SHAFT SAE A - 2 Bolt Flange Mount

PART #	cu.in/ rev	Rotation	MAX psi	MAX RPM	GPM@ 1800rpm	SAE Ports
GP-F20-04-P-A	0.24	C.C.W.	3650	3600	1.87	<b>INLET</b> #12 ORB 1-1/16"-12
GP-F20-04-P-C	0.24	C.W.	3650	3600	1.87	
GP-F20-06-P-A	0.36	C.C.W.	3650	3600	2.81	
GP-F20-06-P-C	0.36	C.W.	3650	3600	2.81	
GP-F20-08-P-A	0.48	C.C.W.	3650	3600	3.74	
GP-F20-08-P-C	0.48	C.W.	3650	3600	3.74	
GP-F20-10-P-A	0.61	C.C.W.	3650	3600	4.75	
GP-F20-10-P-C	0.61	C.W.	3650	3600	4.75	
GP-F20-12-P-A	0.73	C.C.W.	3650	3600	5.69	
GP-F20-12-P-C	0.73	C.W.	3650	3600	5.69	
GP-F20-14-P-A	0.85	C.C.W.	3650	3600	6.62	
GP-F20-14-P-C	0.85	C.W.	3650	3600	6.62	
GP-F20-16-P-A	0.97	C.C.W.	2900	3600	7.56	
GP-F20-16-P-C	0.97	C.W.	2900	3600	7.56	
GP-F20-20-P-A	1.22	C.C.W.	2900	3600	9.51	
GP-F20-20-P-C	1.22	C.W.	2900	3600	9.51	
GP-F20-25-P-A	1.52	C.C.W.	2900	3600	11.84	
GP-F20-25-P-C	1.52	C.W.	2900	3600	11.84	
GP-F20-30-P-A	1.83	C.C.W.	2300	3600	14.26	<b>INLET</b> #16 ORB 1-5/16"-12
GP-F20-30-P-C	1.83	C.W.	2300	3600	14.26	
GP-F20-32-P-A	1.95	C.C.W.	2300	3600	15.20	
GP-F20-32-P-C	1.95	C.W.	2300	3600	15.20	<b>OUTLET</b> #12 ORB 1-1/16"-12

# CENTRAL HYDRAULICS INC.

•Daytona Beach •Cocoa •Leesburg •Ocala •Tampa 1-800-264-9571

## Hydraulic Gear Pump

### 3/4" LONG KEYED SHAFT



#### Performance Data

PART # (L)CW (R)CCW	ci.	Max PSI	GPM@ 1800rpm	PORT
2GG9U05L	.30	4200	2.34	INLET #20 ORB 1-5/8"-12
2GG9U05R	.30	4200	2.34	
2GG9U07L	.43	4200	3.35	
2GG9U07R	.43	4200	3.35	
2GG9U08L	.52	4200	4.05	
2GG9U08R	.52	4200	4.05	
2GG9U09L	.58	4200	4.52	
2GG9U09R	.58	4200	4.52	
2GG9U11L	.69	4200	5.38	
2GG9U11R	.69	4200	5.38	
2GG9U14L	.85	4200	6.62	
2GG9U14R	.85	4200	6.62	
2GG9U16L	.98	4200	7.63	
2GG9U16R	.98	4200	7.63	
2GG9U18L	1.10	4200	8.57	
2GG9U18R	1.10	4200	8.57	
2GG9U20L	1.20	4200	9.35	
2GG9U20R	1.20	4200	9.35	
2GG9U22L	1.31	4200	10.20	
2GG9U22R	1.31	4200	10.20	
2GG9U24L	1.44	3000	11.22	
2GG9U24R	1.44	3000	11.22	
2GG9U26L	1.53	3000	11.92	
2GG9U26R	1.53	3000	11.92	
2GG9U28L	1.71	3000	13.32	
2GG9U28R	1.71	3000	13.32	
2GG9U30L	1.84	3000	14.34	
2GG9U30R	1.84	3000	14.34	
2GG9U33L	2.02	3000	15.74	
2GG9U33R	2.02	3000	15.74	

OUTLET  
#16 ORB  
1-5/16"-12

INLET  
#16 ORB  
1-5/16"-12

OUTLET  
#12 ORB  
1-1/16"-12

2G cast iron pump covers ensure up to 3500 psi working pressure. The extruded body and pressure loaded bearing blocks are made from the highest quality aluminum. Precision machined ne peice steel gears guarantee the highest performance standard available. Honor gear pumps are well suited for both industrial and mobile applications, and are very competetive so you can meet the competition with a good price advantage.

# CENTRAL HYDRAULICS INC.

•Daytona Beach •Cocoa •Leesburg •Ocala •Tampa 1-800-264-9571

## Hydraulic Gear Pump

**F10 - 1/2" Dia. Straight  
SAE AA - 2 Bolt Flange Mount  
2" Pilot**



Model GP-F10 is an all aluminium construction, high pressure Hydraulic Gear Pump with 7 displacement sizes from 0.07 to 0.48 cu.in/rev. (1.3 to 8.0 cm<sup>3</sup>/rev). The standard mounting flange is SAE AA – 2 bolt, standard ports are SAE-8 inlet and SAE-6 outlet, and standard drive shaft is 1/2 inch straight shaft with 1/8 inch key.

PART #	cu.in/ rev	Rotation	MAX psi	MAX RPM	GPM@ 1800rpm	SAE Ports
GP-F10-13-P-A	0.08	C.C.W.	3650	5000	0.62	<b>INLET</b> #8 ORB 3/4"-16  <b>OUTLET</b> #6 ORB 9/16"-18
GP-F10-13-P-C	0.08	C.W.	3650	5000	0.62	
GP-F10-20-P-A	0.12	C.C.W.	3650	5000	0.94	
GP-F10-20-P-C	0.12	C.W.	3650	5000	0.94	
GP-F10-27-P-A	0.16	C.C.W.	3650	5000	1.25	
GP-F10-27-P-C	0.16	C.W.	3650	5000	1.25	
GP-F10-34-P-A	0.20	C.C.W.	3650	5000	1.56	
GP-F10-34-P-C	0.20	C.W.	3650	5000	1.56	
GP-F10-41-P-A	0.25	C.C.W.	3650	4000	1.95	
GP-F10-41-P-C	0.25	C.W.	3650	4000	1.95	
GP-F10-51-P-A	0.31	C.C.W.	3650	4000	2.42	
GP-F10-51-P-C	0.31	C.W.	3650	4000	2.42	
GP-F10-61-P-A	0.37	C.C.W.	2900	4000	2.88	
GP-F10-61-P-C	0.37	C.W.	2900	4000	2.88	
GP-F10-80-P-A	0.48	C.C.W.	2900	4000	3.74	
GP-F10-80-P-C	0.48	C.W.	2900	4000	3.74	



# CENTRAL HYDRAULICS INC.

•Daytona Beach •Cocoa •Leesburg •Ocala •Tampa 1-800-264-9571

## Hydraulic Gear Pump



Model GP-F20 offers aluminium body and cast Iron end plate construction, high pressure Hydraulic Gear Pump with 11 displacement sizes from 0.24 to 1.95 cu.in/rev.

### F20 - 3/4" Dia. Straight SAE A - 2 Bolt Flange Mount

Part #	cu.in/rev	Rotation	PSI	MAX RPM	GPM@ 1800	SAE Ports
GP-F20-04-P1-A	0.24	C.C.W.	3650	3600	1.87	<b>INLET</b> #12 ORB 1-1/16"-12  <b>OUTLET</b> #10 ORB 7/8"-14
GP-F20-04-P1-C	0.24	C.W.	3650	3600	1.87	
GP-F20-06-P1-A	0.36	C.C.W.	3650	3600	2.81	
GP-F20-06-P1-C	0.36	C.W.	3650	3600	2.81	
GP-F20-08-P1-A	0.48	C.C.W.	3650	3600	3.74	
GP-F20-08-P1-C	0.48	C.W.	3650	3600	3.74	
GP-F20-10-P1-A	0.61	C.C.W.	3650	3600	4.75	
GP-F20-10-P1-C	0.61	C.W.	3650	3600	4.75	
GP-F20-12-P1-A	0.73	C.C.W.	3650	3600	5.69	
GP-F20-12-P1-C	0.73	C.W.	3650	3600	5.69	
GP-F20-14-P1-A	0.85	C.C.W.	3650	3600	6.62	
GP-F20-14-P1-C	0.85	C.W.	3650	3600	6.62	
GP-F20-16-P1-A	0.97	C.C.W.	2900	3600	7.56	
GP-F20-16-P1-C	0.97	C.W.	2900	3600	7.56	
GP-F20-20-P1-A	1.22	C.C.W.	2900	3600	9.50	
GP-F20-20-P1-C	1.22	C.W.	2900	3600	9.50	
GP-F20-25-P1-A	1.52	C.C.W.	2900	3600	11.84	
GP-F20-25-P1-C	1.52	C.W.	2900	3600	11.84	
GP-F20-30-P1-A	1.83	C.C.W.	2300	3600	14.26	<b>INLET</b> #16 ORB 1-5/16"-12 <b>OUTLET</b> #12 ORB 1-1/16"-12
GP-F20-30-P1-C	1.83	C.W.	2300	3600	14.26	
GP-F20-32-P1-A	1.95	C.C.W.	2300	3600	15.19	
GP-F20-32-P1-C	1.95	C.W.	2300	3600	15.19	

# CENTRAL HYDRAULICS INC.

•Daytona Beach •Cocoa •Leesburg •Ocala •Tampa 1-800-264-9571

## Hydraulic Gear Pump



### F25 7/8" Keyed Shaft 2 Bolt "B" Flange 4" Pilot Side Ported

**Model GP-F25** is a aluminium center section and cast iron end plate construction, high pressure Hydraulic Gear Pump with 10 displacement sizes from 1.34 to 5.43 cu. in/rev.

Part #	cu.in/rev	Rotation	PSI	MAX RPM	SAE ORB Ports
GP-F25-22-P-C	1.34	C.W.	3625	3000	<b>INLET</b> #16 ORB 1-5/16"-12  <b>OUTLET</b> #12 ORB 1-1/16"-12
GP-F25-22-P-A	1.34	C.C.W.	3625	3000	
GP-F25-25-P-C	1.59	C.W.	3625	3000	
GP-F25-25-P-A	1.59	C.C.W.	3625	3000	
GP-F25-34-P-C	2.07	C.W.	3625	3000	
GP-F25-34-P-A	2.07	C.C.W.	3625	3000	
GP-F25-39-P-C	2.38	C.W.	3625	3000	
GP-F25-39-P-A	2.38	C.C.W.	3625	3000	
GP-F25-43-P-C	2.62	C.W.	3625	2800	
GP-F25-43-P-A	2.62	C.C.W.	3625	2800	
GP-F25-51-P-C	3.11	C.W.	3625	2800	
GP-F25-51-P-A	3.11	C.C.W.	3625	2800	
GP-F25-60-P-C	3.84	C.W.	2900	2800	
GP-F25-60-P-A	3.84	C.C.W.	2900	2800	
*GP-F25-70-P-C	4.27	C.W.	2900	2500	<b>INLET</b> #20 ORB 1-5/8"-12  <b>OUTLET</b> #16 ORB 1-5/16"-12
*GP-F25-70-P-A	4.27	C.C.W.	2900	2500	
*GP-F25-78-P-C	4.76	C.W.	2900	2300	
*GP-F25-78-P-A	4.76	C.C.W.	2900	2300	
*GP-F25-89-P-C	5.43	C.W.	2300	2000	
*GP-F25-89-P-A	5.43	C.C.W.	2300	2000	

# CENTRAL HYDRAULICS INC.

•Daytona Beach •Cocoa •Leesburg •Ocala •Tampa 1-800-264-9571

## Hydraulic Gear Pump

### F25 7/8-13tooth Spline Shaft 2 Bolt "B" Flange 4" Pilot Side Ported

**Model GP-F25** is a aluminium center section and cast iron end plate construction, high pressure Hydraulic Gear Pump with 10 displacement sizes from 1.34 to 5.43 cu. in/rev.



Part #	cu.in/rev	Rotation	PSI	Max RPM	SAE ORB Ports
GP-F25-22-S13-C	1.34	C.W.	3625	3000	<b>INLET</b> #16 ORB 1-5/16"-12
GP-F25-22-S13-A	1.34	C.C.W.	3625	3000	
GP-F25-25-S13-C	1.59	C.W.	3625	3000	
GP-F25-25-S13-A	1.59	C.C.W.	3625	3000	
GP-F25-34-S13-C	2.07	C.W.	3625	3000	
GP-F25-34-S13-A	2.07	C.C.W.	3625	3000	
GP-F25-39-S13-C	2.38	C.W.	3625	3000	
GP-F25-39-S13-A	2.38	C.C.W.	3625	3000	
GP-F25-43-S13-C	2.62	C.W.	3625	2800	
GP-F25-43-S13-A	2.62	C.C.W.	3625	2800	
GP-F25-51-S13-C	3.11	C.W.	3625	2800	
GP-F25-51-S13-A	3.11	C.C.W.	3625	2800	
GP-F25-60-S13-C	3.84	C.W.	2900	2800	
GP-F25-60-S13-A	3.84	C.C.W.	2900	2800	
*GP-F25-70-S13-C	4.27	C.W.	2900	2500	<b>INLET</b> #20 ORB 1-5/8"-12
*GP-F25-70-S13-A	4.27	C.C.W.	2900	2500	
*GP-F25-78-S13-C	4.76	C.W.	2900	2300	
*GP-F25-78-S13-A	4.76	C.C.W.	2900	2300	
*GP-F25-89-S13-C	5.43	C.W.	2300	2000	
*GP-F25-89-S13-A	5.43	C.C.W.	2300	2000	

# CENTRAL HYDRAULICS INC.

•Daytona Beach •Cocoa •Leesburg •Ocala •Tampa 1-800-264-9571

## Lift Gate Motors

### 12v Heavy Duty

#### MONARCH

*\*Position 3/9 Bolts*



#### MON8111

CCW, TANG  
Heavy Duty  
SERIES  
MDY, MHA, MHN,  
MMY, MUE

7027	7068	4001	4001-A
7057	7059	7004	6106
6001	6001-S	7006	BMT0021
8111-D	8111-A	4005	8112

#### FENNER (spx)



#### SPX KMD-1

CW, 9-SPLINE  
Heavy Duty  
SERIES  
MDY, MFX, MMY

6116-S	7032-A	7039	7061
7022	7032-B	7039-S	7063
7031	7037	7042	7066
7032	7037-S	7042-A	7066-S
4002	4001-S	4001	

#### FENNER (spx)



#### AMT0077

CW, TANG  
Heavy Duty

1175-AC	1197-AC	1787-AC	1789-AC
1185-AC	1931-AC	1785-AC	

#### MAXON

*\*Position 5/11 Bolts*



#### BMT0167

CCW, TANG  
Heavy Duty

	6119
229272	250093
P33818	39200398
MYD7057	6104

*\*position of mounting bolt when facing the drive & hot post is at 12:00\**

# CENTRAL HYDRAULICS INC.

•Daytona Beach •Cocoa •Leesburg •Ocala •Tampa 1-800-264-9571

## Hydraulic Valves

Single Spool



Double Spool



Triple Spool



**SBA Series-** The Cross SBA series valve is a 3-position, 4-way valve in 1, 2, or 3 spool versions with float option available. Fully balanced select-fit honed spools with excellent metering characteristics give a maximum load holding capability.

### Features

- 2500 psi operating pressure\*
- 30 gpm flow rating
- 3/4" NPT inlet & outlet ports
- 1/2" NPT work ports
- 2000 psi adjustable relief valve
- Open center, spring centered
- Load holding cylinder port check valves

Part Number	Options
1V0208	Power Beyond Sleeve
1V0206	Closed Center Plug
1V0294	3-Position Detent
1V0096	3-way 3-Pos Spool



Made in the U.S.A.



**MANUFACTURING, INC.**

### USES

- Double-acting cylinder or motor.
- Float position allows a dozer blade to ride the contours of the ground.

Part #	Description
<b>SBA2</b>	Single Spool, 3-position, 4-way
<b>SBA22</b>	Double Spool, both 3-position, 4-way
<b>SBA222</b>	Triple Spool, all 3-position, 4-way
<b>SBAF2</b>	Double Spool, 1st spool 4-position, with detent in float, 2nd spool 3-position
<b>SBAF22</b>	Triple Spool, 1st spool 4-position, with detent in float, 2nd & 3rd spools 3-pos.

Fax: 386-257-5728 Tele. 1-800-264-9571 sales@centralhydraulics.com www.centralhydraulics.com

**CRO-175-F-01**

# CENTRAL HYDRAULICS INC.

•Daytona Beach •Cocoa •Leesburg •Ocala •Tampa 1-800-264-9571



**Monobloc and sectional directional control valves**

Custom designs available

We keep the Monobloc styles in stock!

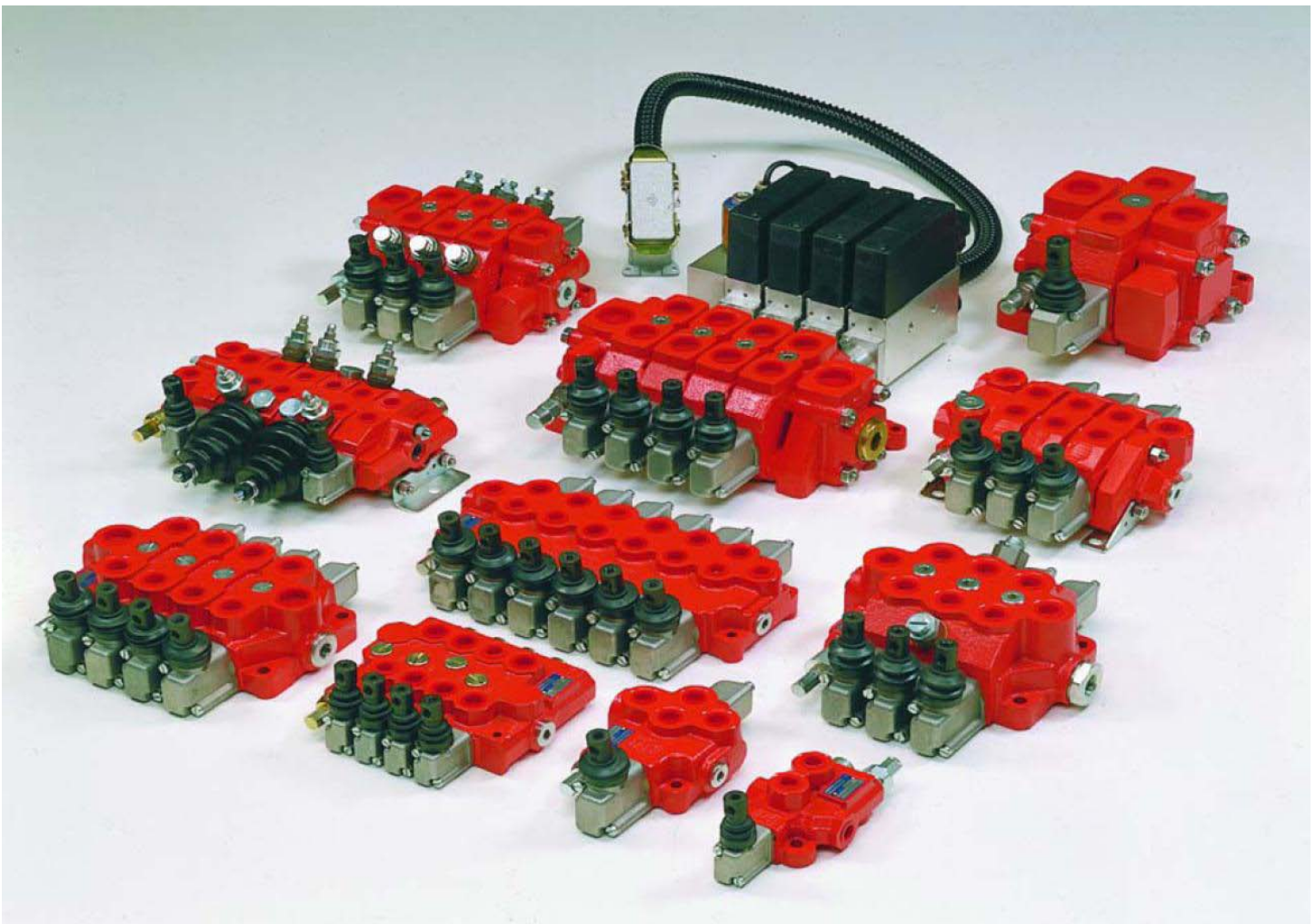

Fax: 386-257-5728 Tele. 1-800-264-9571 sales@centralhydraulics.com www.centralhydraulics.com

# CENTRAL HYDRAULICS INC.

•Daytona Beach •Cocoa •Leesburg •Ocala •Tampa 1-800-264-9571

## MANUAL CONTROL VALVES

4-way 3-Position S/C to neutral

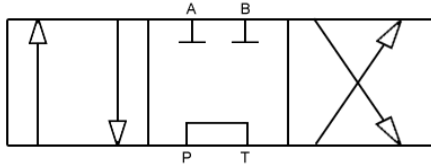

**HDM140 - 1 spool**  
P/N 200051417006



**BUCHER**  
HYDRAULICS

**Monoblock - 8 O-Ring Boss**  
**Max. 10gpm - 3600psi**  
(SOLD SEPERATELY)

6" Handle  
P/N 200702210190

Detent Kit  
P/N 200768520010

**IN STOCK!**

**HDM11P - 2 spool**  
P/N 200061127007

**HDM11P - 3 spool**  
P/N 200061137011

**HDM11P - 4 spool**  
P/N 200061147007

**HDM11P - 5 spool**  
P/N 200061157003

**HDM11P - 6 spool**  
P/N 200061167007

**Monoblock - 8 O-Ring Boss**  
**Max. 12gpm - 3600psi**

(SOLD SEPERATELY)

6" Handle  
P/N 200702210190

3 POS DETENT  
P/N 200768520010

Power Beyond Option  
P/N 200527160201



**IN STOCK!**

**IN STOCK!**



**Monoblock - 10 O-Ring Boss**

**Max. 18gpm - 5000psi**

(SOLD SEPERATELY)

7-1/4" Handle  
P/N 200702220010

Detent Kit  
P/N 200968620140

Power Beyond Option  
P/N 200770000460

**HDM18 - 1 spool**  
P/N 200071818007

**HDM18 - 2 spool**  
P/N 200071828010

**HDM18 - 3 spool**  
P/N 200071838025

**HDM18 - 4 spool**  
P/N 200071848007

# CENTRAL HYDRAULICS INC.

•Daytona Beach •Cocoa •Leesburg •Ocala •Tampa 1-800-264-9571

## Sectional Electric Control Valves

**12vDC HDS11**

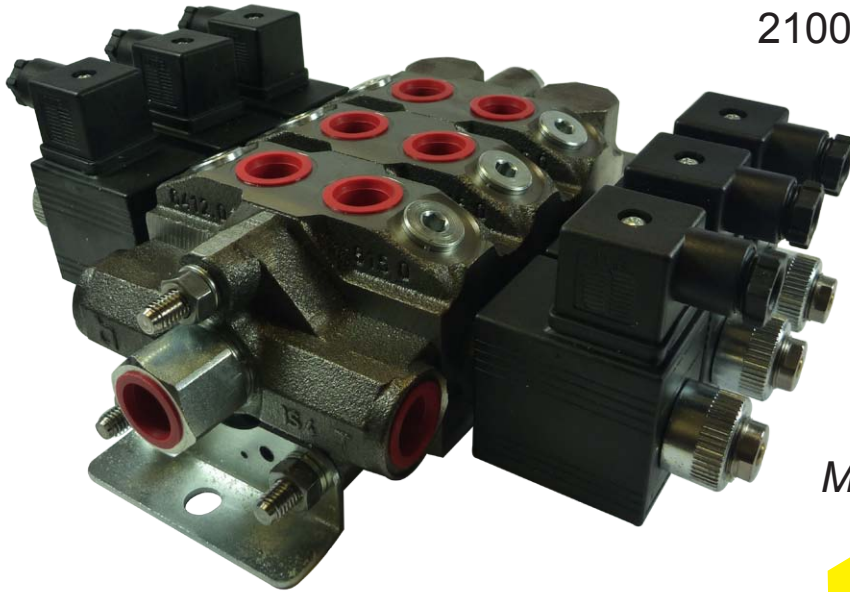

12gpm Max Flow

2100 - 3600 psi Relief Standard  
up to 5000 psi available

1-6 Spools Assemblies

#8 ORB Ports

4-Way 3-Pos is Standard

*Many Spool Options Available!*

**Custom  
Built from  
Stock in  
24 Hours!**

Inlet w/Relief	200931070030
Outlet - Standard	200630070010
Outlet with Power Beyond HPCO	200930070020
Section 4way 3position A/B closed	200741270017
Mounting Bracket	200677200421
-- -- 2 Section Assembly	20001127002
-- -- 3 Section Assembly	530020300
-- -- 3 Section w/Power Beyond	530021817

\* Bolt Kits Based on Number of Spools

 **BUCHER**  
HYDRAULICS



# CENTRAL HYDRAULICS INC.

•Daytona Beach •Cocoa •Leesburg •Ocala •Tampa 1-800-264-9571

## Sectional Directional Control Valves



**Custom  
Built from  
Stock in  
24 Hours!**

### HDS20

25gpm Max Flow  
3600 Max operating pressure  
1-10 Spools Assemblies  
Adjustable Direct Acting Relief Valve

#12 ORB Inlet/Outlet  
#10 ORB Work Ports  
4-Way 3-Position is Standard

*Many Spool Options Available!*

#12 ORB LH Inlet w/relief	200787400800
#12 ORB RH Outlet w/HPCO	200930490080
#12 ORB RH Outlet Standard	200930490020
#10 ORB 4-Way 3-Pos Cylinder Spool Section	200741480001
#10 ORB MTR Spool Section ABT Common	200741480005
3 Position Detent Kit	200968620020
7.25" Handle	200702220010

\* Bolt Kits Based on Number of Spools



# CENTRAL HYDRAULICS INC.

•Daytona Beach •Cocoa •Leesburg •Ocala •Tampa 1-800-264-9571

## Sectional Directional Control Valves



**Custom  
Built from  
Stock in  
24 Hours!**

### HDS30

35 Gpm Max Flow

3600 Max operating pressure

1-10 Spools Assemblies

#16 ORB Inlet/Outlet

#12 ORB Work Ports

4-Way 3-Position is Standard

*Many Spool Options Available!*

#16 ORB LH Inlet w/relief	200931690020
#16 ORB RH Outlet w/HPCO	200930490040
#16 ORB RH Outlet Standard	200630690030
#12 ORB 4-Way 3-Pos Cylinder Spool Section	200741690001
#12 ORB MTR Spool Section ABT Common	600130100549
3 Position Detent Kit	200968620020
7.25" Handle	200702220010

\* Bolt Kits Based on Number of Spools

**b** **BUCHER**  
HYDRAULICS

Fax: 386-257-5728 Tele. 1-800-264-9571 sales@centralhydraulics.com www.centralhydraulics.com

# CENTRAL HYDRAULICS INC.

•Daytona Beach •Cocoa •Leesburg •Ocala •Tampa 1-800-264-9571

## Rotary-Actuated Control Valves



The valve handle is rotated to actuate the spool, as opposed to shifting the spool axially. This provides finer metering control. These valves incorporate a mechanical detent in the neutral position.

- Flows up to 30 gpm max
- Pressure up to 2,500psi

**20050** -- 3/4" In/Out 1/2" Work Ports  
**20051** -- 3/4" In/Out 3/4" Work Ports

**WARNING:** These valves do not contain load checks and therefore should not be used in lifting applications unless some other means of holding the load is provided.

### Rotary - Actuated SERIES Valves

**IN STOCK!**

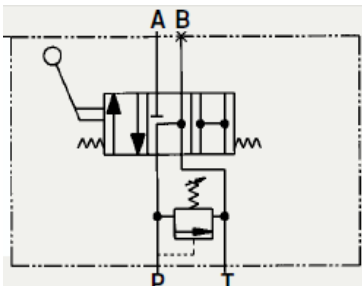

**Rotary Spool Three-Way Tandem Center with Relief Valve**  
 MODEL NUMBER  
**20048-1/2" NPTF Ports**  
**20049-3/4" NPTF Ports**  
 (SAE ORB Ports also Available)

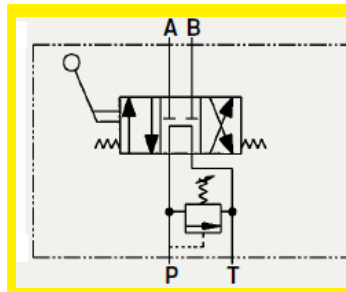

**Rotary Spool Four-Way Tandem Center with Relief Valve**  
 MODEL NUMBER  
**20050-1/2" NPTF Ports**  
**20051-3/4" NPTF Ports**  
 (SAE ORB Ports also Available)

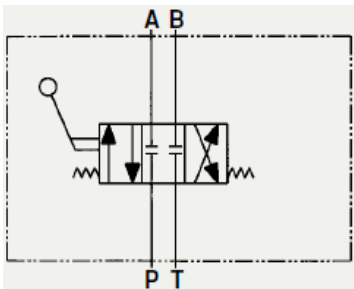

**Rotary Spool Three-Way Closed Center no Relief Valve**  
 MODEL NUMBER  
**10217-1/2" NPTF Ports**  
**10218-3/4" NPTF Ports**  
 (SAE ORB Ports also Available)

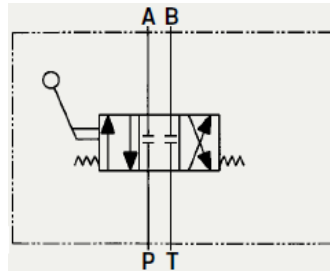

**Rotary Spool Four-Way Closed Center no Relief Valve**  
 MODEL NUMBER  
**10219-1/2" NPTF Ports**  
**10220-3/4" NPTF Ports**  
 (SAE ORB Ports also Available)

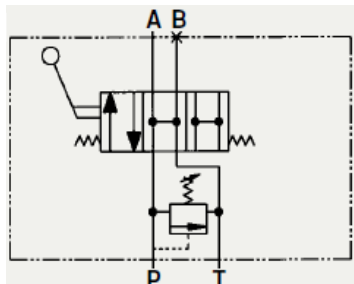

**Rotary Spool Three-Way Open Center with Relief Valve**  
 MODEL NUMBER  
**10238-1/2" NPTF Ports**  
**10239-3/4" NPTF Ports**  
 (SAE ORB Ports also Available)

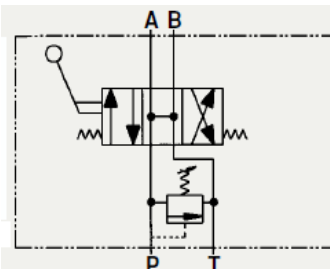

**Rotary Spool Four-Way Open Center with Relief Valve**  
 MODEL NUMBER  
**10240-1/2" NPTF Ports**  
**10241-3/4" NPTF Ports**  
 (SAE ORB Ports also Available)

# CENTRAL HYDRAULICS INC.

•Daytona Beach •Cocoa •Leesburg •Ocala •Tampa 1-800-264-9571

## 4-Way Directional Control Valve

### Common "DC SERIES" Stock #'s

DC	75	T	3	L	B	S
DC	75	T	4	H	E	B
DC	16	O	4	L	B	D
DC	16	T	3	L	B	D
DC	16	T	3	L	B	S
DC	16	T	4	L	B	D
DC	16	T	4	L	B	S
	<b>1</b>	<b>2</b>	<b>3</b>	<b>4</b>	<b>5</b>	<b>6</b>

### 1 SERIES

DC – 4-way directional control valve

### 2 PORT SIZE

75 – 3/4" inlet/outlet and work ports

16 – #16 SAE inlet/outlet and work ports

### 3 SPOOL TYPE

T3 – Tandem center 3-way (DC only)  
(Omit 4)

C – Closed center (DC only)

T – Tandem center (DC only)

O – Open center (DC only)

M – Fine metering

TM – Tandem metering

### 4 3-WAY or 4-WAY

3 – 3-way (Tandem spool and DC only)

4 – 4-way

### 5 ACTUATORS

L – Lever handle (B port is active when handle is pushed)

H – Rotary handle (Used in conjunction

with rotary ball friction detent (E))

### 6 SPOOL ATTACHMENTS

S – Spring center

D – Three-position detent

F1 – Ball friction detent

B – High lift ball spring relief for DC (TS-B)

E – Rotary ball friction detent

45 gpm  
3000 psi  
#16 SAE ORB  
3/4" NPT

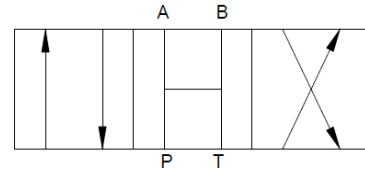
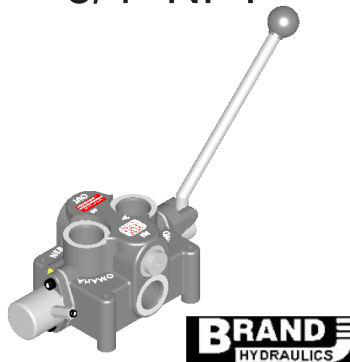

**Open Center (O)** - All of the ports are connected to tank when the spool is in neutral. Allows cylinder to move or motor to rotate when spool is in neutral. This spool is not designed for DCF valve.

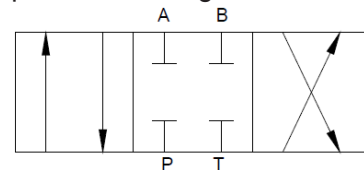

**Closed Center (C)** - All ports are blocked in neutral. Blocks cylinder or motor in neutral. Required for use with pressure compensated pump. This is not available for DCF valve.

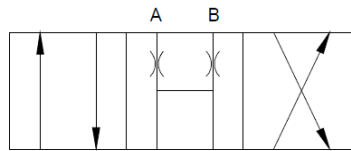

**Fine Metering Spool (M)** - The pressure drop in neutral is higher than the (TM) spool. Requires external locking valves to hold cylinder, because ports A and B are open (orificed) in the neutral position. Extremely fine metering control. This spool is designed for the DCF valve and acts as closed center in DC valve.

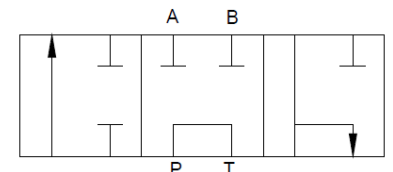

**Tandem Three Way (T3)** - Powers the cylinder in one direction. Pump unloads to tank when spool is in neutral, or when spool is being reversed. Cylinder is blocked when spool is in neutral. Port "B" is plugged. This spool is designed for the DC valve.

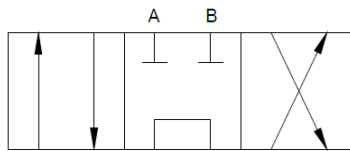

**Tandem Metering Spool (TM)** - Similar to (T) spool except much finer metering control. The pressure drop in neutral is lower than the (M) spool. Cylinder or motor blocked in neutral and pump unloads to tank. This spool is designed for DCF valve.

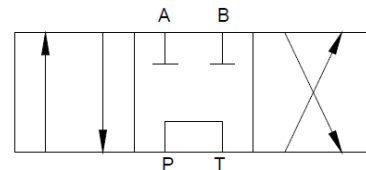

**Tandem Center (T)** - Powers cylinder or motor in both directions (metering capability is very limited). Pump unloads to tank when spool is in neutral. Cylinder or motor blocked when spool in neutral. This spool is not designed for DCF valve.

# CENTRAL HYDRAULICS INC.

•Daytona Beach •Cocoa •Leesburg •Ocala •Tampa 1-800-264-9571

## FINALLY!

A **DIRECT** replacement for the  
**Gresen/Parker SPW4HP Rotary Spool Valve**

- Same bolt mounting pattern!
- Flows up to 30gpm
- Adj. Pressure up to 2500psi
- 3/4" npt in/out 1/2" npt work ports

**\*\*New valve includes a handle!**

*\*Load Check Sold Separately!*

Part # **HOS SPW4HP-20050**



American-made in the U.S.A.!

# CENTRAL HYDRAULICS INC.

•Daytona Beach •Cocoa •Leesburg •Ocala •Tampa 1-800-264-9571

## DELTROL

*fluid products*

DIVISION OF DELTROL CORP



### Cartridge Valves

Spool and  
Poppet types



Fax: 386-257-5728 Tele. 1-800-264-9571 sales@centralhydraulics.com www.centralhydraulics.com

# CENTRAL HYDRAULICS INC.

•Daytona Beach •Cocoa •Leesburg •Ocala •Tampa 1-800-264-9571



## 2-Way 2-Position Cartridge Valves

**Poppet Type**  
(10v 12v 110v 220v)

Part #	Description
<p><b>NORMALLY CLOSED</b></p> <p><b>DSV-080-2NCP-N</b> Up to 5gpm</p> <p><b>DSV2-100-2NCP-N</b> Up to 16gpm</p>	<p>A cartridge valve designed with positive shut off to be used in load holding applications.</p> <p><b>OPERATION</b></p> <p>When <i>de-energized</i>, the DSV-2NCP acts as a check valve, allowing flow from ① to ②, while blocking flow from ② to ①.</p> <p>When <i>energized</i>, the poppet lifts to open the ② to ① flow path.</p>

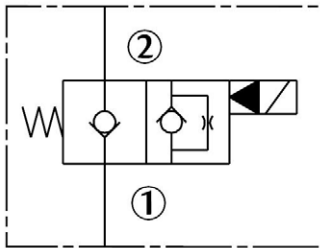
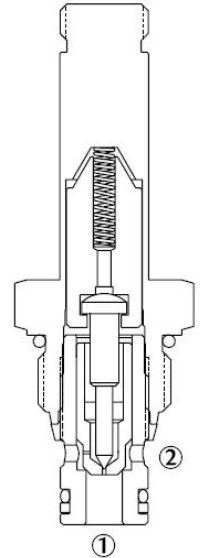

**DELTROL**  
*fluid products*  
DIVISION OF DELTROL CORP 

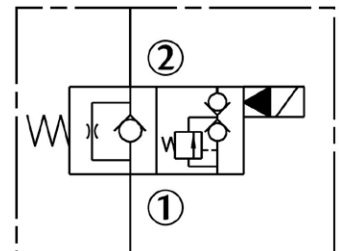

Part #	Description
<p><b>NORMALLY OPEN</b></p> <p><b>DSV-080-2NOP-N</b> Up to 5gpm</p> <p><b>DSV2-100-2NOP-N</b> Up to 16gpm</p>	<p>A cartridge valve designed with positive shut off to be used in load holding applications.</p> <p><b>OPERATION</b></p> <p>When <i>de-energized</i>, the DSV-2NOP is open to allow flow from ② to ①.</p> <p>When <i>energized</i>, the poppet closes to block the flow from ② to ①. In this condition, the cartridge allows reverse flow from ① to ②.</p>

# CENTRAL HYDRAULICS INC.

•Daytona Beach •Cocoa •Leesburg •Ocala •Tampa 1-800-264-9571



## 2-Way 2-Position Cartridge Valves

**Spool Type**  
(10v 12v 110v 220v)

Part #	Description
<b>NORMALLY CLOSED</b>	A cartridge valve designed to operate as a bidirectional blocking valve.
<b>DSV2-080-2NCS-N</b> Up to 3gpm	<b>OPERATION</b> When <i>de-energized</i> , the DSV-2NCS blocks flow in both directions.
<b>DSV2-100-2NCS-N</b> Up to 3gpm	When <i>energized</i> , the cartridge's spool shifts to allow flow in either direction.

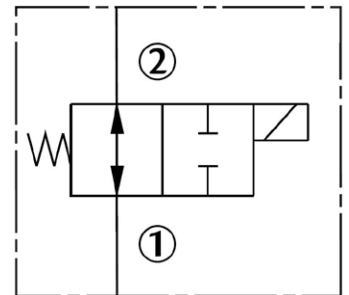
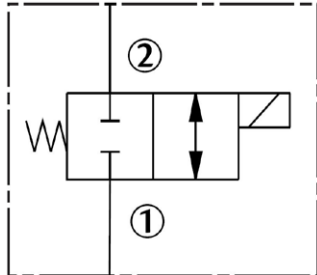
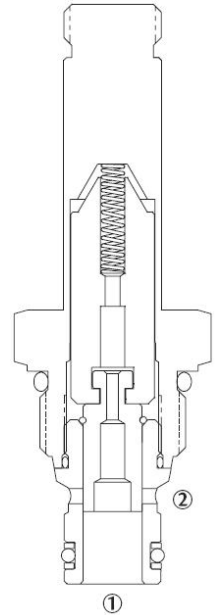

Part #	Description
<b>NORMALLY OPEN</b>	A cartridge valve designed to operate as a bidirectional blocking valve.
<b>DSV2-080-2NOS-N</b> Up to 3gpm	<b>OPERATION</b> When <i>de-energized</i> , the DSV-2NOS allows flow in both directions.
<b>DSV2-100-2NOS-N</b> Up to 6gpm	When <i>energized</i> , the cartridge's spool shifts to block flow in either direction.



# CENTRAL HYDRAULICS INC.

•Daytona Beach •Cocoa •Leesburg •Ocala •Tampa **1-800-264-9571**



## 3-Way 2-Position Cartridge Valves

**Spool Type**  
(10v 12v 110v 220v)

Part #	Description
<b>DSV2-080-3-N</b> Up to 4gpm	<p>A cartridge valve designed as a three-way, spool-type, directional control valve.</p> <p><b>OPERATION</b></p> <p>When <i>de-energized</i>, the DSV-3 allows flow between ② and ①, while blocking flow at ③.</p> <p>When <i>energized</i>, the cartridge's spool shifts to allow flow between ① and ③ while blocking flow at ②.</p>
<b>DSV2-100-3-N</b> Up to 6gpm	

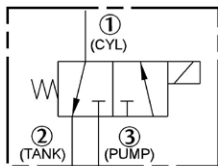
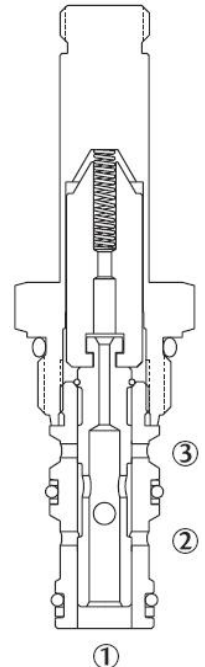

NORMALLY CLOSED

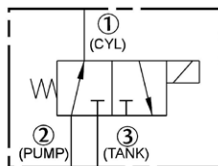

NORMALLY OPEN

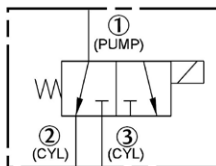

SELECTOR

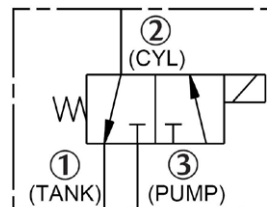

NORMALLY CLOSED

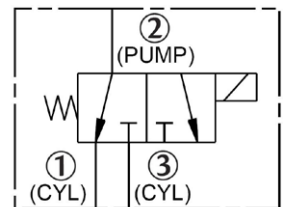

SELECTOR

Part #	Description
<b>DSV2-080-3B-N</b> Up to 5gpm	<p>A cartridge valve designed as a three-way, spool-type, directional control valve.</p> <p><b>OPERATION</b></p> <p>When <i>de-energized</i>, the DSV-3B allows flow between ② and ①, while blocking flow at ③.</p> <p>When <i>energized</i>, the cartridge's spool shifts to allow flow between ② and ③ while blocking flow at ①.</p>
<b>DSV2-100-3B-N</b> Up to 6gpm	

# CENTRAL HYDRAULICS INC.

•Daytona Beach •Cocoa •Leesburg •Ocala •Tampa **1-800-264-9571**



## 4-Way 2-Position Cartridge Valves

**Spool Type**  
(10v 12v 110v 220v)

Part #	Description
<b>NORMALLY CLOSED</b>	Spool-type, directional control valve with all ports normally-closed
<b>DSV2-080-4NC-N</b> Up to 3gpm	<b>OPERATION</b> When <i>de-energized</i> , the DSV2-4NC flow paths are blocked.
<b>DSV2-100-4NC-N</b> Up to 6gpm	When <i>energized</i> , the cartridge's spool shifts and allows flow from ③ to ④ and from ② to ①.

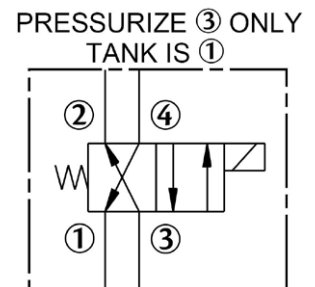
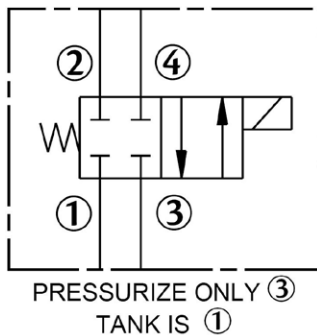
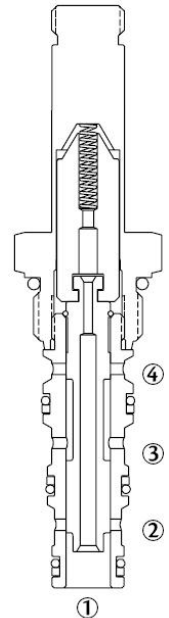

Part #	Description
<b>NORMALLY CLOSED</b>	Spool-type, directional control valve with all ports normally-open.
<b>DSV2-080-4CO-N</b> Up to 3gpm	<b>OPERATION</b> When <i>de-energized</i> , the DSV2-4CO allows flow from ③ to ②, and from ④ to ①.
<b>DSV2-100-4CO-N</b> Up to 6gpm	When <i>energized</i> , the cartridge's spool shifts to allow flow between ③ and ④ and from ② to ①.

# CENTRAL HYDRAULICS INC.

•Daytona Beach •Cocoa •Leesburg •Ocala •Tampa 1-800-264-9571



## 4-Way 2-Position Cartridge Valves

**Spool Type**  
(10v 12v 110v 220v)

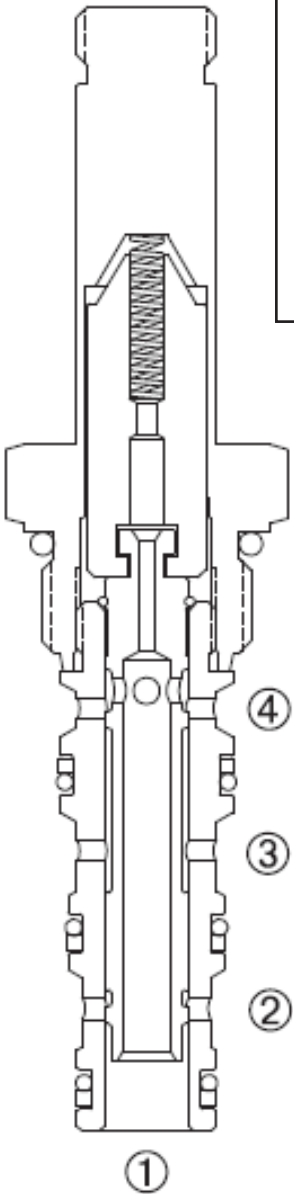

Part Number	Description
DSV2-080-4TC-N Up to 3gpm	Spool-type, directional control valve with two ports normally-closed and two ports normally-open` <b>OPERATION</b> When <i>de-energized</i> , the DSV2-4TC allows flow from ④ to ① and is blocked at ② and ③.  When <i>energized</i> , the cartridge's spool shifts and allows flow from ④ to ③ and from ② to ① .
DSV2-100-4TC-N Up to 6gpm	

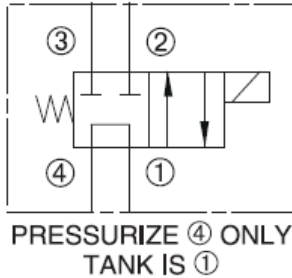

# DELTROL

Part Number	Description
DSV2-080-4NO-N Up to 3gpm	A cartridge valve designed as a four-way, spool-type, directional control valve with all ports normally-open. This valve is commonly used in a circuit to allow flow to and from a double-acting cylinder or motor. <b>OPERATION</b> When <i>energized</i> , the spool shifts and all flow paths are blocked. When <i>de-energized</i> , the cartridge's spool allows flow from ③ to ④ and from ② and ①.
DSV2-100-4NO-N Up to 3gpm	

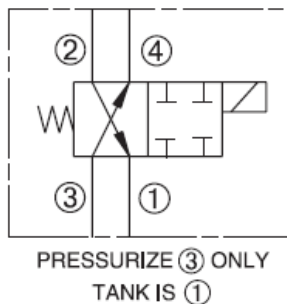

# CENTRAL HYDRAULICS INC.

•Daytona Beach •Cocoa •Leesburg •Ocala •Tampa 1-800-264-9571



## 4-Way 3-Position Motor Center or Tandem Center Cartridge Valves

Spool Type

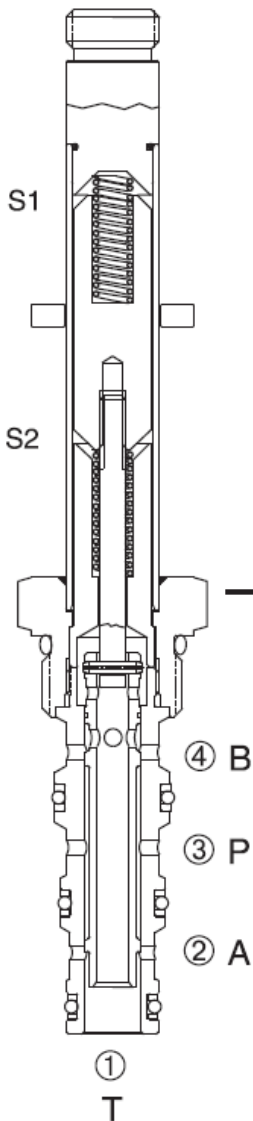

Part #	Description
DSV-080-34M-N Up to 3.5gpm	A cartridge valve designed as a three position, four-way solenoid valve. <b>OPERATION</b> When <i>de-energized</i> , the valve allows flow between the ①, ②, and ④ ports with the ③ port blocked. When the upper solenoid (S1) is <i>energized</i> , the valve allows flow between ② and ① ports and the ③ and ④ ports. When the lower solenoid (S2) is <i>energized</i> , the valve allows flow between the ④ and ① ports and the ③ and ② ports.
DSV-100-34M-N Up to 6gpm	

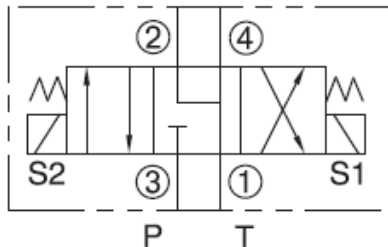

# DELTROL

Part #	Description
DSV-080-34T-N Up to 3gpm	A cartridge valve designed as a three position, four-way solenoid valve. <b>OPERATION</b> When <i>de-energized</i> , the valve allows flow between the ③ and ① ports with ports ② and ④ blocked. When the lower solenoid (S2) is <i>energized</i> , the valve allows flow between the ① and ② ports and the ③ and ④ ports. When the upper (S1) solenoid is <i>energized</i> , the valve allows flow between the ① and ④ ports and the ② and ③ ports.
DSV-100-34T-N Up to 5gpm	

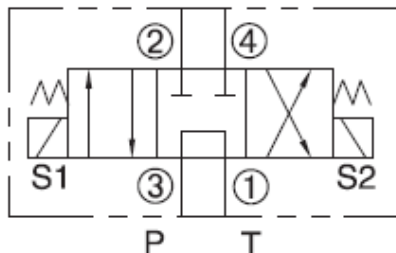

# CENTRAL HYDRAULICS INC.

•Daytona Beach •Cocoa •Leesburg •Ocala •Tampa 1-800-264-9571



## 4-Way 3-Position Closed Center or Open Center Cartridge Valves

Spool Type

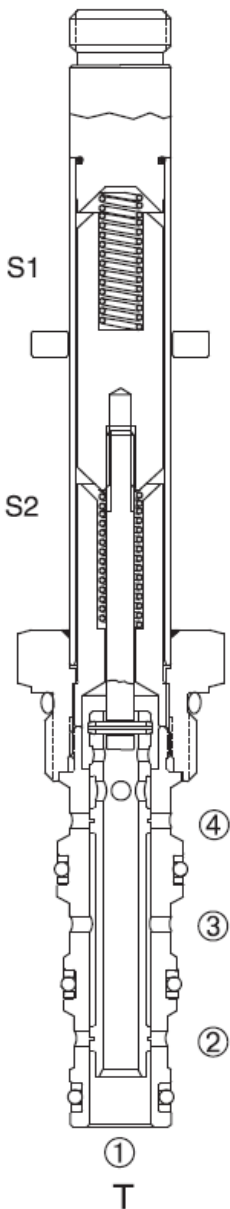

Part #	Description
DSV-080-34C-N Up to 3gpm	A B A cartridge valve designed as a three position, four-way solenoid valve. <b>OPERATION</b> When <i>de-energized</i> , the valve prevents flow at all ports. When the upper solenoid (S1) is <i>energized</i> , the valve allows flow between the ② and ① ports and the ③ and ④ ports. When the lower solenoid (S2) is <i>energized</i> , the valve allows flow between the ④ and ① ports and the ③ and ② ports.
DSV-100-34C-N Up to 6gpm	

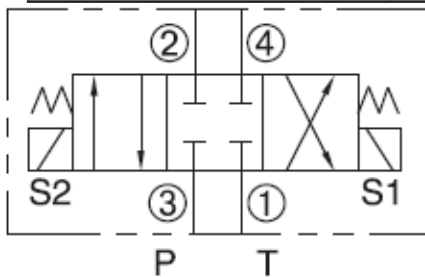

# DELTROL

Part #	Description
DSV-080-34O-N Up to 2gpm	A B A cartridge valve designed as a three position, four-way solenoid valve. <b>OPERATION</b> When <i>de-energized</i> , the valve allows flow at all ports. When the upper solenoid (S1) is <i>energized</i> , the valve allows flow between the ③ and ② ports and the ④ and ① ports. When the lower solenoid (S2) is <i>energized</i> , the valve allows flow between the ③ and ④ ports and the ② and ① ports.
DSV-100-34O-N Up to 3gpm	

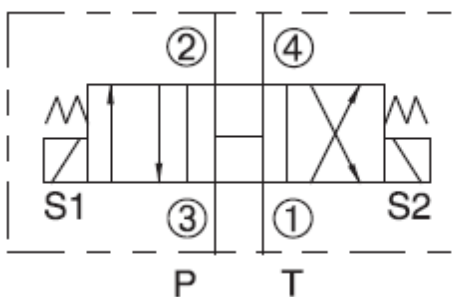

**fluid products**  
DIVISION OF DELTROL CORP 

# CENTRAL HYDRAULICS INC.

•Daytona Beach •Cocoa •Leesburg •Ocala •Tampa 1-800-264-9571

## Aluminum Cartridge Blocks

### 3000 PSI

#### Two Way Two Position

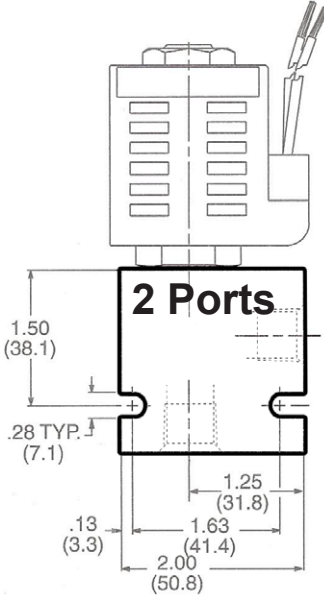

Part #	Description
10138-44	B-080-2-2N 2W/2POS 1/4" NPT
10138-47	B-080-2-6T 2W/2POS #6 ORB
10138-48	B-100-2-2N 2W/2POS 1/4" NPT
10138-49	B-100-2-3N 2W/2POS 3/8" NPT
10138-51	B-100-2-8T 2W/2POS #8 ORB

(All cartridge valves & coils sold separately)

#### Three Way Two Position

Part #	Description
10134-93	B-080-3-6T 3W/2POS #6 ORB
10134-98	B-100-3-6T 3W/2POS #6 ORB
10134-99	B-100-3-8T 3W/2POS #8 ORB

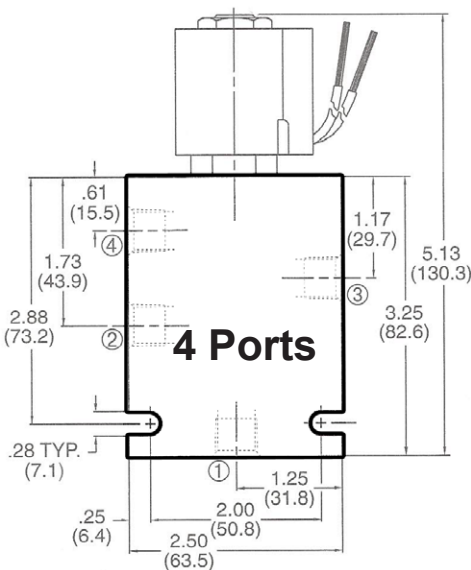
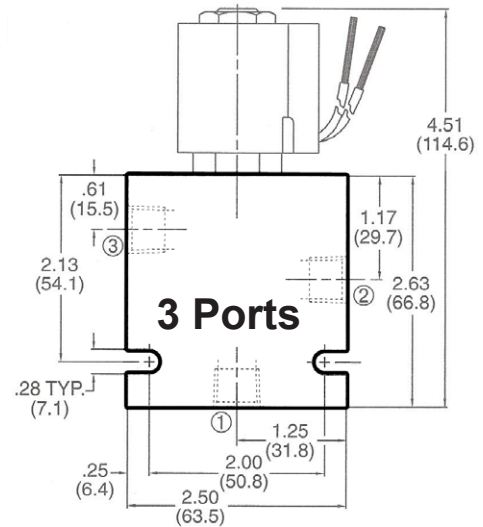

#### Four Way Two Position

Part #	Description
10134-35	B-080-4-2N 4W/2 POS 1/4" NPT
10134-38	B-080-4-6T 4W/2 POS #6 ORB
10134-39	B-100-4-2N 4W/2 POS 1/4" NPT
10134-40	B-100-4-3N 4W/2 POS 3/8" NPT
10134-42	B-100-4-8T 4W/2 POS #8 ORB

# CENTRAL HYDRAULICS INC.

•Daytona Beach •Cocoa •Leesburg •Ocala •Tampa 1-800-264-9571

## Aluminum Cartridge Blocks

### 3000 PSI

(All cartridge valves & coils sold separately)

#### Four Way Three Position

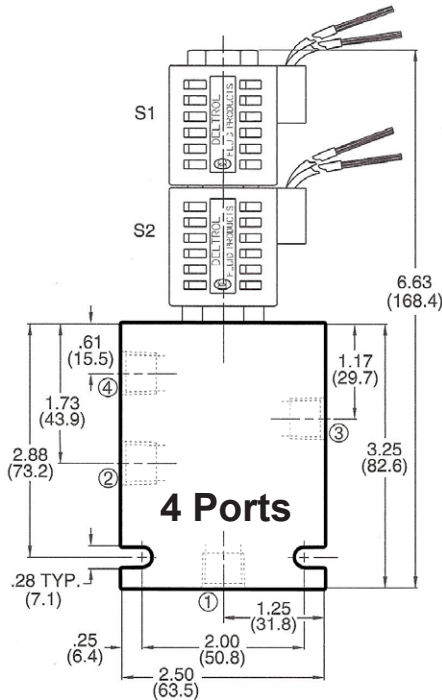

Part #	Description
10134-35	B-080-4-2N 4W/3 POS 1/4" NPT
10134-38	B-080-4-6T 4W/3 POS #6 ORB
10134-39	B-100-4-2N 4W/3 POS 1/4" NPT
10134-40	B-100-4-3N 4W/3 POS 3/8" NPT
10134-42	B-100-4-8T 4W/3 POS #8 ORB

# DELTROL

*fluid products*

DIVISION OF DELTROL CORP



# CENTRAL HYDRAULICS INC.

•Daytona Beach •Cocoa •Leesburg •Ocala •Tampa 1-800-264-9571

## Solenoid Coil Data

### 80 Series - 1/2" ID Center Hole

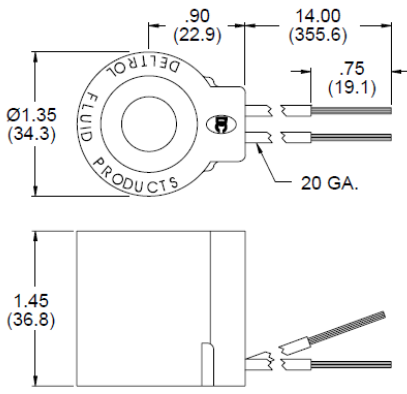

**\*\*D**  
DOUBLE LEADS

PART #	VOLTS	WATTS
10148-57	120v	
10184-42	12v	
10226-37	10v	
10231-42	24v	
10238-66	12v	
10148-51	12v	

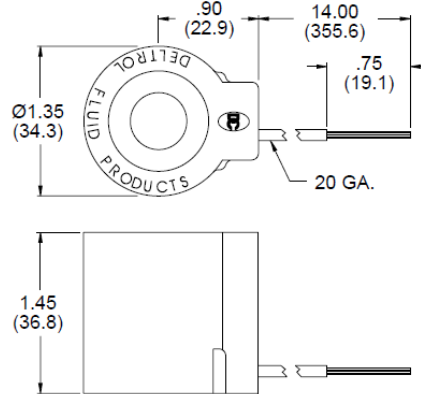

**\*\*S**  
SINGLE LEAD (D'S ONLY)

PART #	VOLTS	WATTS
10116-30	12v	
10148-52	12v	

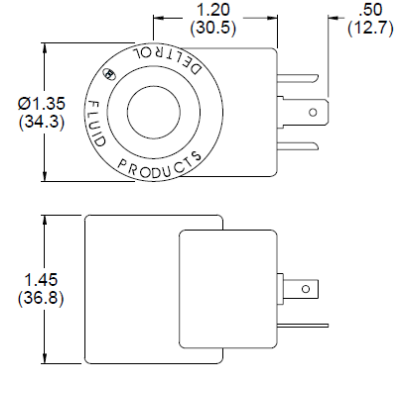

**\*\*H**  
HIRSCHMANN® GSR 200  
(2 POLE + GROUND APPLI-  
ANCE PLUG) TO DIN 43650

PART #	VOLTS	WATTS
10148-79	240v	
10148-80	120v	
10148-81	24v	

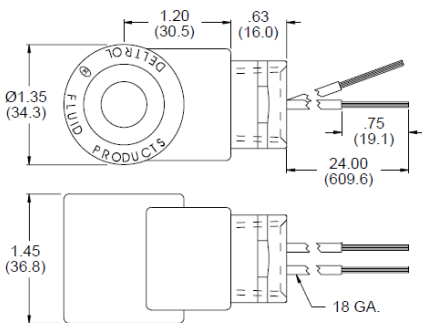

**\*\*C**  
CONDUIT (FEMALE 1/2-14 NPT)

PART #	VOLTS	WATTS
10148-70	120v	

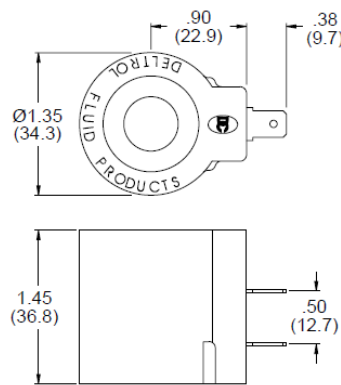

**\*\*B**  
DOUBLE SPADE  
1/4" MALE QUICK-CONNECT  
PER SAE J858A (TYPE 1B)

PART #	VOLTS	WATTS
10148-53	12v	
10148-56	120v	
10149-62	24v	
10166-25	20v	16w
10226-37	10v	

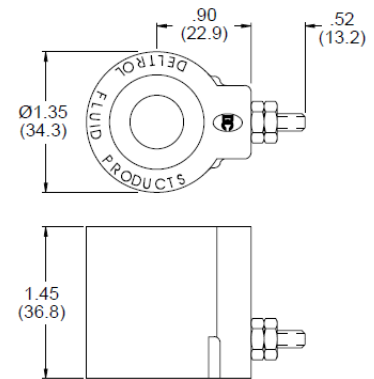

**\*\*E**  
SINGLE STUD  
8-32 MALE STUD  
WITH 2 BRASS NUTS

PART #	VOLTS	WATTS
10196-61	12v	
10196-62	24v	



# CENTRAL HYDRAULICS INC.

•Daytona Beach •Cocoa •Leesburg •Ocala •Tampa 1-800-264-9571

## Solenoid Coil Data

### 100 Series - 5/8" ID Center Hole

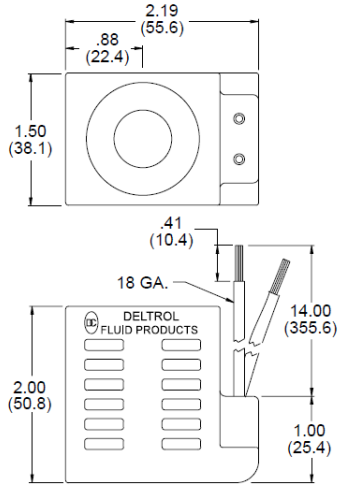

**\*\*D**  
DOUBLE LEADS

PART #	VOLTS	WATTS
10162-76	12vDC	
10162-77	24vDC	
10162-82	110/120v	

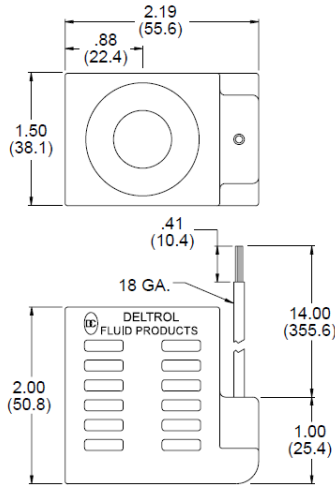

**\*\*S**  
SINGLE LEAD (D'S ONLY)

PART #	VOLTS	WATTS
10164-10	12vDC	

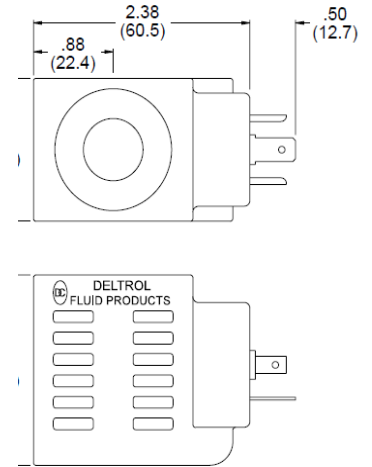

**\*\*H**  
HIRSCHMANN® GSR 200  
1/2 POLE ± GROUND & 1/2 L.

PART #	VOLTS	WATTS
10162-78	12v	
10162-79	24v	
10162-84	120v	
10162-85	240vAC	

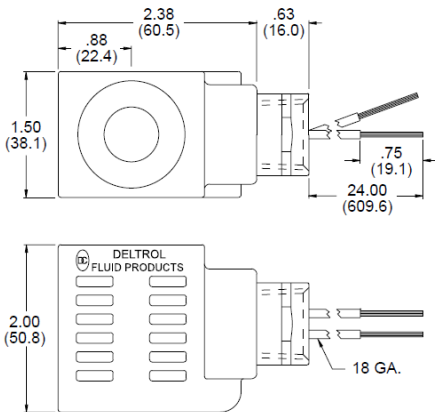

**\*\*C**  
CONDUIT (FEMALE 1/2-14 NPT)

PART #	VOLTS	WATTS
10162-86	110v	
10162-87	240vAC	

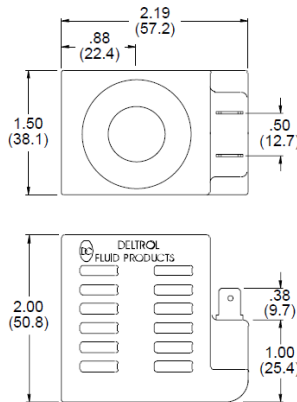

**\*\*B**  
DOUBLE SPADE  
1/4" MALE QUICK-CONNECT  
PER SAE J858A (TYPE 1B)

PART #	VOLTS	WATTS
10162-90	120v	
10162-91	12v	
10162-92	24v	
10164-09	240vDC	

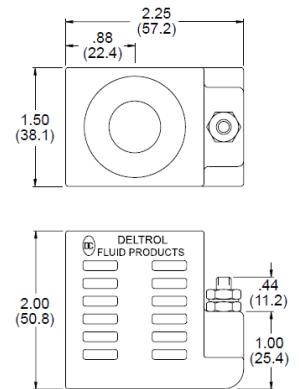

**\*\*E**  
SINGLE STUD  
10-32 MALE STUD WITH  
2 BRASS NUTS AND 1 STEEL  
EXTERNAL TOOTH LOCKWASHER

PART #	VOLTS	WATTS
10164-13	12vDC	
10164-14	24vDC	
10164-73	12vDC	

# CENTRAL HYDRAULICS INC.

•Daytona Beach •Cocoa •Leesburg •Ocala •Tampa 1-800-264-9571



### Normal Operating Pressures

Brass - 2,000psi

Carbon Steel - 5,000psi

Stainless Steel - 5,000psi

(UNLESS OTHERWISE SPECIFIED)

## Flow Control Valves Easy Read

SIZE	BRASS	CARBON STEEL
1/8"	EF10B	EF10S
1/4"	EF20B	EF20S
3/8"	EF25B	EF25S
1/2"	EF30B	EF30S
3/4"	EF35B	EF35S
1"	EF40B	EF40S



Color Band  
Flow Control

## Needle Valves Easy Read

SIZE	BRASS	CARBON STEEL
1/8"	EN10B	EN10S
1/4"	EN20B	EN20S
3/8"	EN25B	EN25S
1/2"	EN30B	EN30S
3/4"	EN35B	EN35S
1"	EN40B	EN40S



Color Band  
Needle Valve

## Ball Check Valves

SIZE	BRASS	CARBON STEEL
1/8"	EC10B	-----
1/4"	EC20B	EC20S
3/8"	EDC25B	EDC25S
1/2"	EDC30B	EDC30S
3/4"	EDC35B	EDC35S
1"	EC40B	EC40S



Check Valve

Cracking Pressure 1-2.5psi

## Globe Check Valves

SIZE	CARBON STEEL
1/4"	S250S1
3/8"	S350S1
3/8"	S450S1
1/2"	S650S1
1"	S850S1

Carbon Steel - 10,000psi



Globe Needle  
Valves

Fax: 386-257-5728 Tele. 1-800-264-9571 sales@centralhydraulics.com www.centralhydraulics.com

# CENTRAL HYDRAULICS INC.

•Daytona Beach •Cocoa •Leesburg •Ocala •Tampa 1-800-264-9571

## Ball Valves

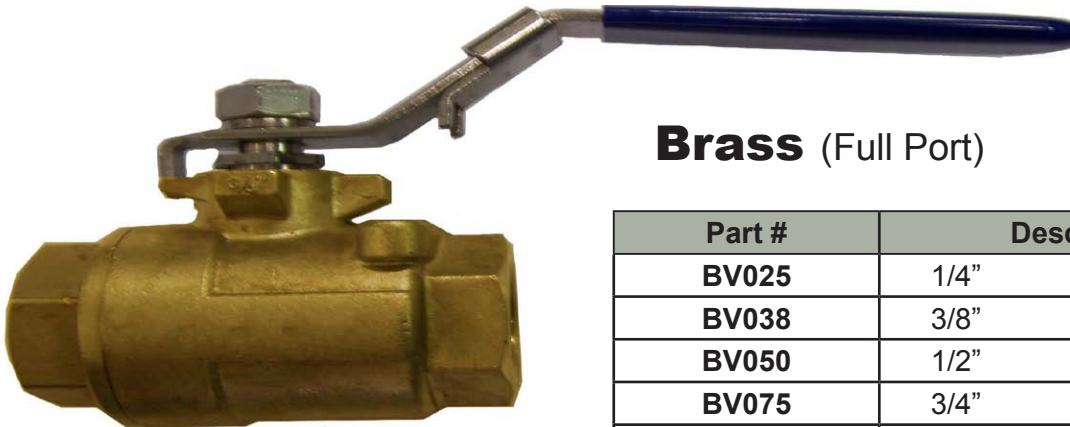

### Brass (Full Port)

Part #	Description	
BV025	1/4"	600 PSI
BV038	3/8"	600 PSI
BV050	1/2"	600 PSI
BV075	3/4"	600 PSI
BV100	1"	600 PSI
BV125	1-1/4"	600 PSI
BV150	1-1/2"	600 PSI
BV200	2"	600 PSI
BV250	2-1/2"	400 PSI
BV300	3"	400 PSI
BV400	4"	400 PSI

All stainless ball valves have locking handles, Teflon seals, and blow-out proof stems.  
Female NPT threads.

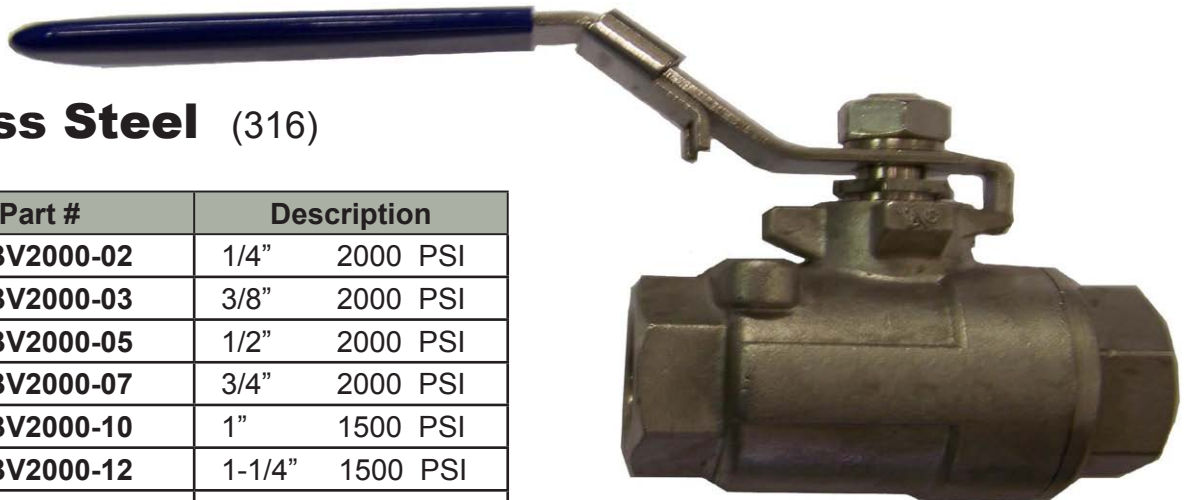

### Stainless Steel (316)

Part #	Description	
SSBV2000-02	1/4"	2000 PSI
SSBV2000-03	3/8"	2000 PSI
SSBV2000-05	1/2"	2000 PSI
SSBV2000-07	3/4"	2000 PSI
SSBV2000-10	1"	1500 PSI
SSBV2000-12	1-1/4"	1500 PSI
SSBV2000-15	1-1/2"	1500 PSI

# CENTRAL HYDRAULICS INC.

•Daytona Beach •Cocoa •Leesburg •Ocala •Tampa 1-800-264-9571

## High Pressure Ball Valves



**DE2**



**DB2**

	Part Number	Thread	PSI
	DE2-14-NPT	1/4" NPT	7250
	DE2-38-NPT	3/8" NPT	7250
	DE2-12-NPT	1/2" NPT	7250
	DE2-34-NPT	3/4" NPT	5800
	DE2-1-NPT	1" NPT	5000
Reduced Port	DE2-114R-NPT	1 1/4" NPT	5000
	DE2-112R-NPT	1 1/2" NPT	5000
Full Port	DB2-114-NPT	1 1/4" NPT	5000
	DB2-112-NPT	1 1/2" NPT	5000
	DB2-2-NPT	2 NPT	5000

- Rugged Carbon Steel Construction
- Mounting holes standard
- 1/4" - 2" Sizes and SAE
- Up to 7000 PSI
- Blow-Out Proof Stems
- Various Seal Materials Available
- Full and Reduced Port

	Part Number	Thread	PSI
Full Port	DE2-04-SAE	7/16"-20	7250
	DE2-06-SAE	9/16-18	7250
	DE2-08-SAE	3/4-16	7250
	DE2-12-SAE	1 1/16-12	5800
	DE2-16-SAE	1 5/16-12	5000
Reduced Port	DE2-20R-SAE	1 5/8-12	5000
	DE2-24R-SAE	1 7/8-12	5000
Full Port	DB2-20-SAE	1 5/8-12	5000
	DB2-24-SAE	1 7/8-12	5000
	DB2-32-SAE	2 1/2-12	5000

# CENTRAL HYDRAULICS INC.

•Daytona Beach •Cocoa •Leesburg •Ocala •Tampa 1-800-264-9571

## High Pressure 3-Way Ball Valves



### DE3L/DB3L 3 - Way

	Part Number	Thread	PSI
Full Port	DE3L-14-NPT	1/4" NPT	4500
	DE3L-38-NPT	3/8" NPT	4500
	DE3L-12-NPT	1/2" NPT	4500
	DE3L-34-NPT	3/4" NPT	4500
	DE3L-1-NPT	1" NPT	4500
Reduced Port	DE3L-114R-NPT	1 1/4" NPT	4500
	DE3L-112R-NPT	1 1/2" NPT	4500
Full Port	DB3L-114-NPT	1 1/4" NPT	4500
	DB3L-112-NPT	1 1/2" NPT	4500
	DB3L-2-NPT	2 NPT	4500

- Rugged Carbon Steel Construction
- 1/4" - 2" Sizes
- Up to 4500 PSI
- Blow-Out Proof Stems
- Full and Reduced Port
- NPT and SAE Threads Available

	Part Number	Thread	PSI
Full Port	DE3L-04-SAE	7/16"-20	4500
	DE3L-06-SAE	9/16-18	4500
	DE3L-08-SAE	3/4-16	4500
	DE3L-12-SAE	1 1/16-12	4500
	DE3L-16-SAE	1 5/16-12	4500
Reduced Port	DE3L-20R-SAE	1 5/8-12	4500
	DE3L-24R-SAE	1 7/8-12	4500
Full Port	DB3L-20-SAE	1 5/8-12	4500
	DB3L-24-SAE	1 7/8-12	4500
	DB3L-32-SAE	2 1/2-12	4500

# CENTRAL HYDRAULICS INC.

•Daytona Beach •Cocoa •Leesburg •Ocala •Tampa 1-800-264-9571

## 3500 PSI Flow Meters

# HEDLAND

Aluminum Flow Meters



for Petroleum Fluids

### FEATURES

- Direct reading
- Install in any position
- 360° rotatable guard/scale
- Easier-to-read linear scale
- No flow straighteners or special piping required
- Relatively insensitive to and shock and vibration
- Good viscosity stability
- Temperature up to 240 °F
- Accuracy  $\pm 2\%$  full scale
- Repeatability  $\pm 1\%$
- Special scales available
- Calibrated for .876 S.G.

NOMINAL PORT SIZE	GPM	Part #
1/4" SAE 6	0.1 - 1.0	H200A - 010
	0.2 - 2.0	H200A - 020
1/2" SAE 10	0.1 - 1.0	H600A - 001
	0.2 - 2.0	H600A - 002
	0.5 - 5.0	H600A - 005
	1 - 10	H600A - 010
	1 - 15	H600A - 015
3/4" SAE 12	0.2 - 2.0	H700A - 002
	.05 - 5.0	H700A - 005
	1 - 10	H700A - 010
	2 - 20	H700A - 020
	3 - 30	H700A - 030
1" SAE 16	0.2 - 2.0	H760A - 002
	.05 - 5.0	H760A - 005
	1 - 10	H760A - 010
	2 - 20	H760A - 020
	3 - 30	H760A - 030
	4 - 40	H760A - 040
1-1/4" SAE 20	5 - 50	H800A - 030
	10 - 75	H800A - 050
	10 - 100	H800A - 075
	10 - 100	H800A - 100
	10 - 150	H800A - 150
1-1/2" SAE 24	3 - 30	H860A - 030
	5 - 50	H860A - 050
	10 - 75	H860A - 075
	10 - 100	H860A - 100
	10 - 150	H860A - 150

**THREADS:**

**SAE O-RING BOSS**

**TEMPERATURE RANGE:**

-20 to +240 °F (-29 to +116 °C)

# CENTRAL HYDRAULICS INC.

•Daytona Beach •Cocoa •Leesburg •Ocala •Tampa 1-800-264-9571

## Gauges

- Stainless Steel Case & Bezel
- Brass & Phosphor Bronze Bourdon Tube
- Vacuum to 6,000psi Range
- Dual Scale PSI & BAR
- Accuracy  $\pm 1.6\%$  FSD
- Temperature Range  $-40^{\circ}$  to  $180^{\circ}$  F
- Brass Connection

### CF Series 1-1/2, 2 and 2-1/2 Glycerin Filled



### INSTALLATION DATA

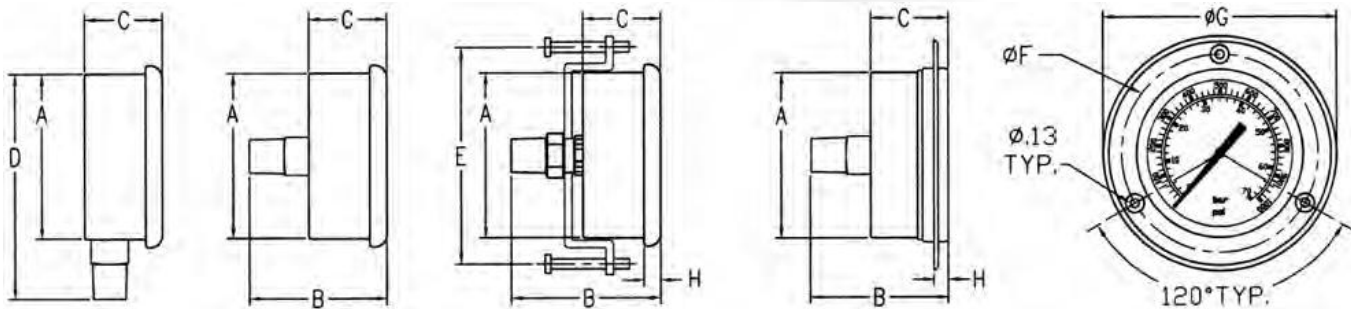

Size	A	B	C	D	E	F	G	H
1 - 1/2"	1.61	1.75	1.00	-	-	-	-	.20
2"	2.00	2.25	1.16	3.09	2.36	2.51	2.87	.21
2 - 1/2"	2.44	2.25	1.14	3.42	3.17	2.93	3.43	.24

<b>Ordering Example:</b>		<b>CF</b>	-	<b>1</b>	<b>P</b>	-	<b>004</b>	-	<b>A</b>
<b>Model</b>	<b>Size</b>	<b>Type</b>	<b>Range</b>						<b>Style</b>
CF	1 to 2-1/2 dia.	C - compound	002 - 30" Hg - 30psi	070 - 1000psi	A - stem				
Designation	5 to 2 dia.	V - vacuum	000 - 30 Hg" - 0psi	100 - 1500psi	B - panel clamp				
for glycerine	*4 to 1-1/2 dia.	P - pressure	001 - 15psi	140 - 2000psi	D - ctr. back				
filled gauges			002 - 30psi	210 - 3000psi	E - panel flange				
			004 - 60psi	280 - 4000psi					
			007 - 100psi	350 - 5000psi					
			010 - 160psi	420 - 6000psi					
			015 - 200psi						
			020 - 300psi						
			040 - 600psi						

\*Note: 1-1/2" available only as a center back mount  
port size - 1/8npt. Limited to 5000psi.

Port Sizes for 2" and 2-1/2" are 1/4npt  
Special sizes subject to minimum order qty.

# CENTRAL HYDRAULICS INC.

•Daytona Beach •Cocoa •Leesburg •Ocala •Tampa 1-800-264-9571

## Metric Conversion Adapters

### NPT Female/Metric Male

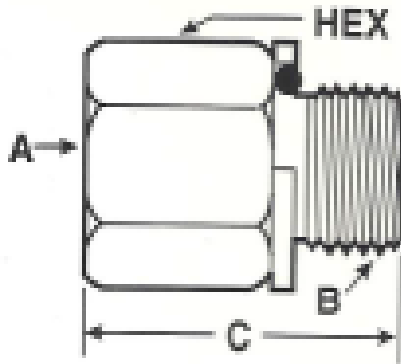

Part #	A	B	C	HEX
PM0210	1/8	10X1	1.18	9/16
PM0412	1/4	12X1.5	1.38	3/4
PM0414	1/4	14X1.5	1.38	3/4
PM0616	3/8	16X1.5	1.47	7/8
PM0618	3/8	18X1.5	1.51	15/16
PM0816	1/2	16X1.5	1.67	1-1/8
PM0818	1/2	18X1.5	1.69	1-1/8
PM0822	1/2	22X1.5	1.77	1-1/8
PM1226	3/4	26X1.5	1.80	1-3/8
PM1227	3/4	27X2	1.80	1-3/8
PM1633	1	33X2	2.00	1-5/8

### NPT Female/BSPP Male

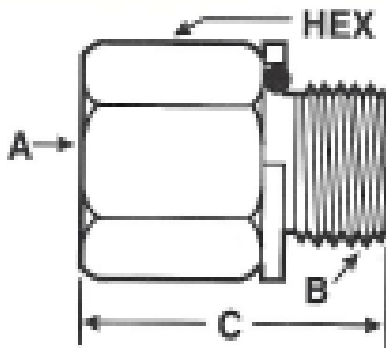

Part #	A	B	C	HEX
PB0202	1/8	1/8	1.06	9/16
PB0204	1/8	1/4	1.20	3/4
PB0402	1/4	1/8	1.22	3/4
PB0404	1/4	1/8	1.42	3/4
PB0606	3/8	3/8	1.46	7/8
PB0808	1/2	1/2	1.77	1-1/8
PB1212	3/4	3/4	1.85	1-3/8
PB1616	1	1	2.00	1-5/8
PB2020	1-1/4	1-1/4	2.21	2-1/8
PB2424	1-1/2	1-1/2	2.51	2-3/8

### NPT Female/BSPT Male

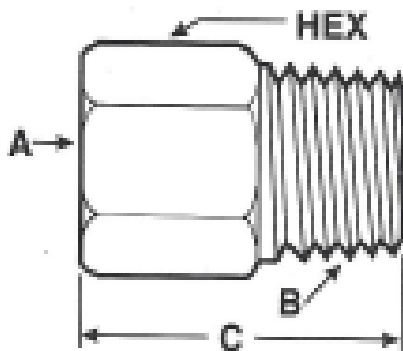

Part #	A	B	C	HEX
PB0202-K	1/8	1/8	.99	9/16
PB0404-K	1/4	1/8	1.34	3/4
PB0606-K	3/8	3/8	1.38	7/8
PB0808-K	1/2	1/2	1.85	1-1/8
PB1212-K	3/4	3/4	1.72	1-3/8
PB1616-K	1	1	1.94	1-5/8
PB2020	1-1/4	1-1/4	2.49	2
PB2424	1-1/2	1-1/2	2.65	2-1/4



# CENTRAL HYDRAULICS INC.

•Daytona Beach •Cocoa •Leesburg •Ocala •Tampa 1-800-264-9571

## Metric Conversion Adapters

### JIC Male/BSPT Male

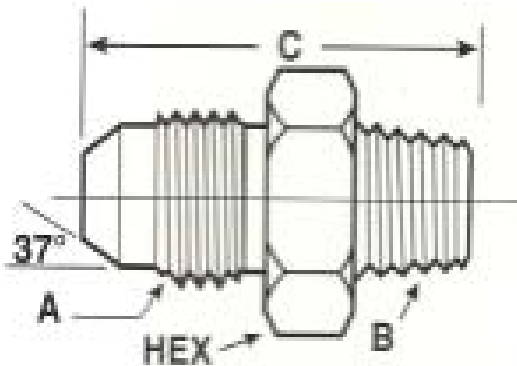

### JIC Male/BSPT Male - 90° Elbow

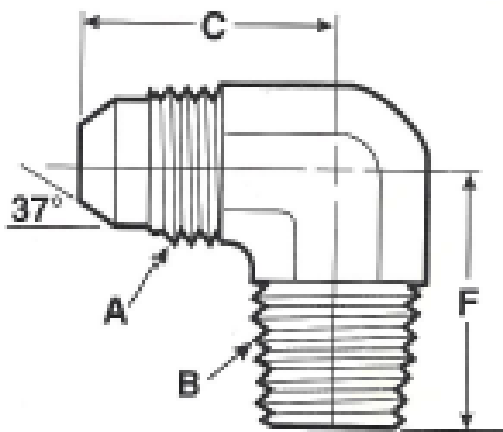

Part #	A	B	C	HEX
JB0202-K	5/16-24	1/8	1.00	7/16
JB0402-K	7/16-20	1/8	1.10	1/2
JB0404-K	7/16-20	1/4	1.22	9/16
JB0406-K	7/16-20	3/8	1.28	3/4
JB0504-K	1/2-20	1/4	1.22	9/16
JB0604-K	9/16-18	1/4	1.21	5/8
JB0606-K	9/16-18	3/8	1.29	3/4
JB0608-K	9/16-18	1/2	1.46	7/8
JB0806-K	3/4-16	3/8	1.41	13/16
JB0808-K	3/4-16	1/2	1.59	15/16
JB1008-K	7/8-14	1/2	1.66	15/16
JB1012-K	7/8-14	3/4	1.83	1-1/8
JB1212-K	1-1/16-12	3/4	1.93	1-1/8
JB1616-K	1-15/16-12	1	2.13	1-1/3
JB2020-K	1-5/8-12	1-1/4	2.34	1-11/16
JB2424-K	1-7/8-12	1-1/2	2.64	2

Part #	A	B	C	F
JB0202-K	5/16-24	1/8	.77	.72
JB0402-K	7/16-20	1/8	.89	.78
JB0404-K	7/16-20	1/4	1.05	1.09
JB0406-K	7/16-20	3/8	1.05	1.22
JB0504-K	1/2-20	1/4	1.05	1.09
JB0604-K	9/16-18	1/4	1.06	1.09
JB0606-K	9/16-18	3/8	1.14	1.22
JB0608-K	9/16-18	1/2	1.22	1.47
JB0806-K	3/4-16	3/8	1.25	1.22
JB0808-K	3/4-16	1/2	1.33	1.47
JB1008-K	7/8-14	1/2	1.45	1.47
JB1012-K	7/8-14	3/4	1.54	1.59
JB1212-K	1-1/16-12	3/4	1.66	1.59
JB1616-K	1-15/16-12	1	1.81	1.97
JB2020-K	1-5/8-12	1-1/4	2.06	2.38
JB2424-K	1-7/8-12	1-1/2	2.33	2.64

# CENTRAL HYDRAULICS INC.

•Daytona Beach •Cocoa •Leesburg •Ocala •Tampa 1-800-264-9571

## Metric Conversion Adapters

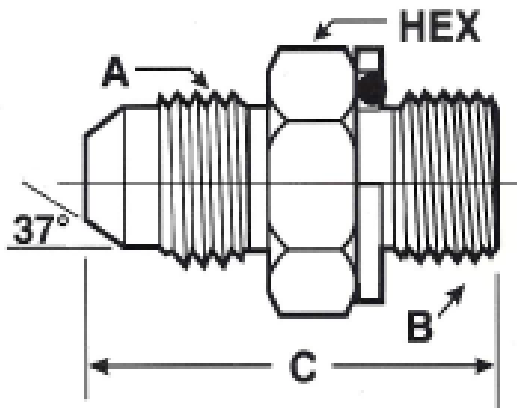

**JIC Male/Metric Male**

Part #	A	B	C	HEX
JM0410	7/16-20	10x1	1.18	5/8
JM0412	7/16-20	12x1.5	1.22	3/4
JM0414	7/16-20	14x1.25	1.25	3/4
JM0614	9/16-18	14x1.5	1.22	3/4
JM0616	9/16-18	16x1.5	1.32	7/8
JM0816	3/4-16	16x1.5	1.42	7/8
JM0818	3/4-16	18x1.5	1.51	1
JM0820	3/4-16	20x1.5	1.65	1
JM0822	3/4-16	22x1.5	1.61	1-1/16
JM1018	7/8-14	18x1.5	1.58	15/16
JM1020	7/8-14	20x1.5	1.71	1
JM1022	7/8-14	22x1.5	1.71	1-1/16
JM1222	1-1/16-12	22x1.5	1.81	1-1/8
JM1226	1-1/16-12	26x1.5	1.91	1-1/4
JM1227	1-1/16-12	27x2	1.95	1-1/4
JM1633	1-5/16-12	33x2	2.03	1-5/8
JM2042	1-5/8-12	42x2	2.19	2

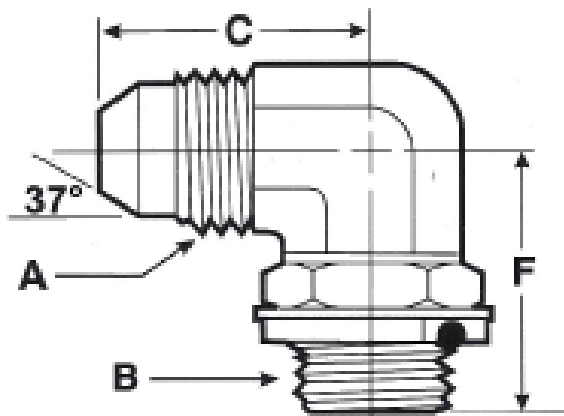

**JIC Male/Metric Male - 90° Elbow**

Part #	A	B	C	F
JM0410-90	7/16-20	10X1	.89	1.03
JM0412-90	7/16-20	12X1.5	.95	1.09
JM0414-90	7/16-20	14X1.25	.95	1.25
JM0614-90	9/16-18	14X1.5	1.06	1.25
JM0616-90	9/16-18	16X1.5	1.14	1.45
JM0816-90	3/4-16	16X1.5	1.25	1.45
JM0818-90	3/4-16	18X1.5	1.26	1.47
JM0822-90	3/4-16	22X1.5	1.33	1.70
JM1018-90	7/8-14	18X1.5	1.41	1.60
JM1020-90	7/8-14	20X1.5	1.45	1.70
JM1022-90	7/8-14	22X1.5	1.45	1.70
JM1222-90	1-1/16-12	22X1.5	1.66	1.78
JM1227-90	1-1/16-12	27X2	1.66	1.94
JM1633-90	1-5/16-12	33X2	1.81	2.05

# CENTRAL HYDRAULICS INC.

•Daytona Beach •Cocoa •Leesburg •Ocala •Tampa **1-800-264-9571**

## Metric Conversion Adapters

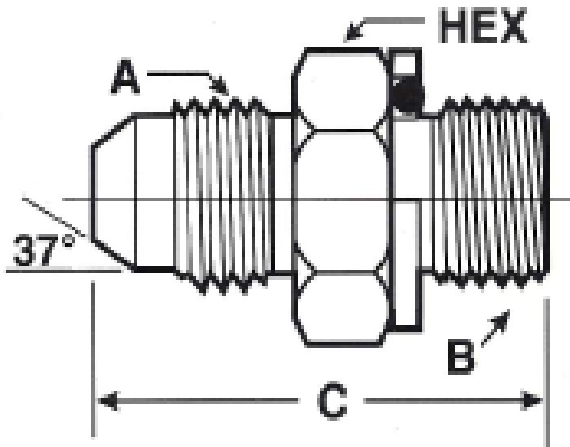

**JIC Male/BSPP Male**

Part #	A	B	C	HEX
JB0402	7/16-20	1/8	1.10	5/8
JB0404	7/16-20	1/4	1.24	3/4
JB0406	7/16-20	3/8	1.30	7/8
JB0504	1/2-20	1/4	1.24	3/4
JB0604	9/16-18	1/4	1.25	3/4
JB0606	9/16-18	3/8	1.34	15/16
JB0608	9/16-18	1/2	1.51	1-1/8
JB0806	3/4-16	3/8	1.48	7/8
JB0808	3/4-16	1/2	1.67	1-1/8
JB1008	7/8-14	1/2	1.71	1-1/8
JB1012	7/8-14	3/4	1.83	1-3/8
JB1212	1-1/16-12	3/4	1.93	1-3/8
JB1612	1-5/16-12	3/4	2.05	1-3/4
JB1616	1-5/16-12	1	2.20	1-3/4
JB1620	1-5/16-12	1-1/4	2.27	2
JB2020	1-5/8-12	1-1/4	2.24	2
JB2024	1-5/8-12	1-1/2	2.44	2-3/8
JB2420	1-7/8-12	1-1/4	2.44	2
JB2424	1-7/8-12	1-1/2	2.44	2-3/8

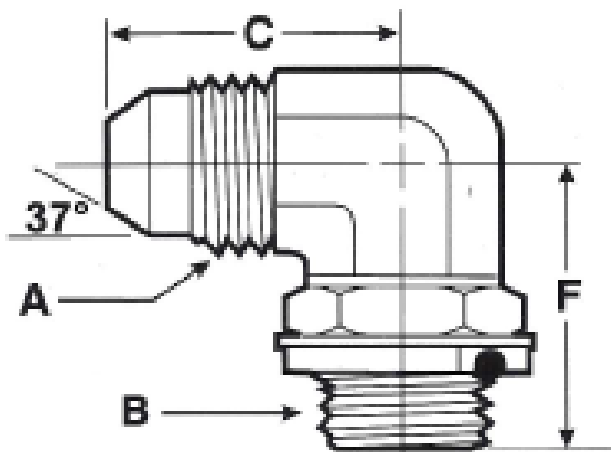

**JIC Male/BSPP Male - 90° Elbow**

Part #	A	B	C	F
JB0402-90	7/16-20	1/8	.89	1.03
JB0404-90	7/16-20	1/4	1.05	1.25
JB0504-90	1/2-20	1/4	1.05	1.29
JB0604-90	9/16-18	1/4	1.06	1.25
JB0606-90	9/16-18	3/8	1.14	1.45
JB0608-90	9/16-18	1/2	1.22	1.70
JB0806-90	3/4-16	3/8	1.25	1.45
JB0808-90	3/4-16	1/2	1.33	1.70
JB0812-90	3/4-16	3/4	1.42	1.94
JB1008-90	7/8-14	1/2	1.45	1.70
JB1012-90	7/8-14	3/4	1.34	1.94
JB1212-90	1-1/16-12	3/4	1.66	1.94
JB1612-90	1-5/16-12	3/4	1.81	2.05
JB1616-90	1-5/16-12	1	1.81	2.05
JB2020-90	1-5/8-12	1-1/4	2.06	2.25
JB2424-90	1-7/8-12	1-1/2	2.33	2.39

# CENTRAL HYDRAULICS INC.

•Daytona Beach •Cocoa •Leesburg •Ocala •Tampa 1-800-264-9571

## Metric Conversion Adapters

### JIC Male/Metric Stand Pipe

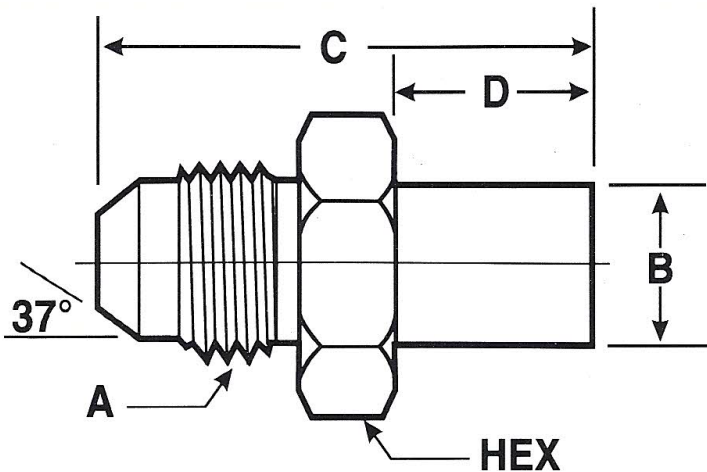

Part #	A	B	C	D	HEX
JT0406	7/16-20	6MM	1.58	.75	9/16
JT0408	7/16-20	8MM	1.68	.88	9/16
JT0610	9/16-18	10MM	1.67	.85	3/4
JT0812	3/4-16	12MM	1.97	1.00	7/8
JT0814	3/4-16	14MM	1.89	.93	7/8
JT1015	7/8-14	15MM	2.03	.91	1
JT1016	7/8-14	16MM	2.07	.95	1
JT1216	1-1/16-12	16MM	2.22	.95	1-1/4
JT1218	1-1/16-12	18MM	2.12	.85	1-1/4
JT1220	1-1/16-12	20MM	2.38	1.11	1-1/4
JT1622	1-5/16-12	22MM	2.21	.89	1-1/2
JT1625	1-5/16-12	25MM	2.54	1.22	1-1/2
JT1630	1-5/16-12	30MM	2.75	34MM	1-1/2
JT1638	1-5/16-12	38MM	2.99	40MM	1-1/2
JT2030	1-5/8-12	30MM	2.88	34MM	1-3/4
JT2038	1-5/8-12	38MM	3.11	40MM	1-3/4

### JIC Male/24° Metric Tube Seal

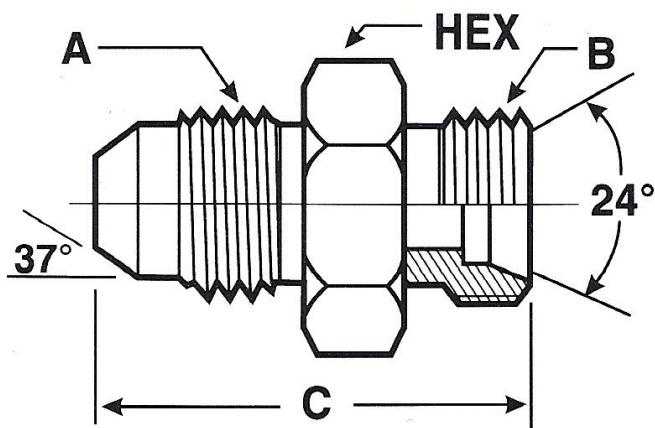

Part #	A	B	C	HEX	TUBE
JM0406-TL	7/16-20	12X1.5	1.21	5/8	6L
JM0608-TL	9/16-18	14X1.5	1.22	3/4	8L
JM0810-TL	3/4-16	16X1.5	1.41	7/8	10L
JM0812-TL	3/4-16	18X1.5	1.48	15/16	12L
JM1015-TL	7/8-14	22X1.5	1.70	1-1/16	15L
JM1218-TL	1-1/16-12	26X1.5	1.91	1-3/4	18L
JM0606-TS	9/16-18	14X1.5	1.22	3/4	6S
JM0608-TS	9/16-18	16X1.5	1.30	3/4	8S
JM0810-TS	3/4-16	18X1.5	1.48	15/16	10S
JM0812-TS	3/4-16	20X1.5	1.49	7/8	12S
JM1014-TS	7/8-14	22X1.5	1.70	1-1/16	14S
JM1216-TS	1-1/16-12	24X1.5	1.77	1-1/8	16S

# CENTRAL HYDRAULICS INC.

•Daytona Beach •Cocoa •Leesburg •Ocala •Tampa 1-800-264-9571

## AeroQuip Quick Disconnects

### AIR COUPLINGS

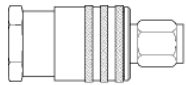

FD40 Series

MIL-C-4109 Interchange—  
Automatic Sleeve

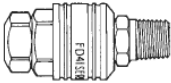

FD41 Series

ARO-210 Interchange

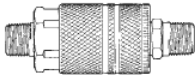

FD43 Series

MIL-C-4109 Interchange—  
Manual Sleeve

### HYDRAULIC—FARM



FD71 Series

Push to Connect  
ISO Interchange



FD72 Series

Push to Connect  
Connect Under Pressure—  
Male ISO Interchange



FD70 Series

Deere Interchange

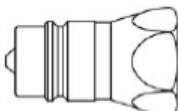

FD76 Series

ISO Standard

### FLUID TRANSFER and HYDRAULIC



5600 Series

General Purpose Industrial  
Interchange  
ISO 7241/1 Series A

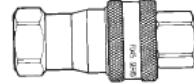

vFD45 Series

Steel...

Bra

Stainless Steel...

Industrial Interchange

ISO 7241/1 Series B

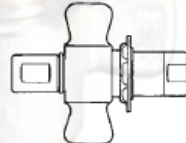

5100 Series

Thread Together—Low Spill

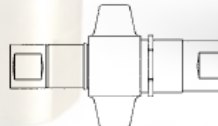

FD86 Series

5000 psi High Impulse—  
DryBreak



FD49 Series

Flush Face—No Spill  
HTMA Interchange

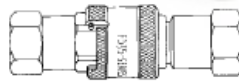

FD35 Series

High Pressure—“Arc Latch™”

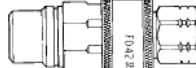

FD42 Series

Pioneer 4000-2 Interchange



FD48 Series

Bruning SM-250 Interchange

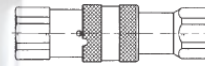

FD89 Series

ISO 16028 Interchange

### FLUID TRANSFER and REFRIGERANT



5400 Series

Low Spill—Low Air Inclusion

### SPECIAL APPLICATION



FD69 Series

Water Blast “Arc Latch™”



FD90 Series

Diagnostic SAE J1502  
Interchange



FD14 Serie

Drain Coupling

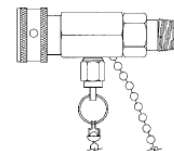

FD15 Series

Oil Sampling Valve

# CENTRAL HYDRAULICS INC.

•Daytona Beach •Cocoa •Leesburg •Ocala •Tampa 1-800-264-9571

## Control Cables



BBU SERIES  
(BULKHEAD TO BULKHEAD)  
INCLUDES NUTS AND WASHERS

### 5200 Series

1/4" -28 Thread S.S. Rod  
3" Travel 8" Bend Radius  
.125 Core  
40-100LB Load Range

Length	Part #
36"	5203BBU036
48"	5203BBU036
60"	5203BBU036
72"	5203BBU036
84"	5203BBU036
96"	5203BBU036
108"	5203BBU036
120"	5203BBU036
144"	5203BBU036

### 6200 Series

5/16" -24 Thread S.S. Rod  
3" Travel 10" Bend Radius  
.188 Core  
110-200LB Load Range

Length	Part #
48"	5203BBU036
60"	5203BBU036
72"	5203BBU036
84"	5203BBU036
96"	5203BBU036
108"	5203BBU036
120"	5203BBU036

# CENTRAL HYDRAULICS INC.

•Daytona Beach •Cocoa •Leesburg •Ocala •Tampa 1-800-264-9571

## DOT Air Brake Fittings

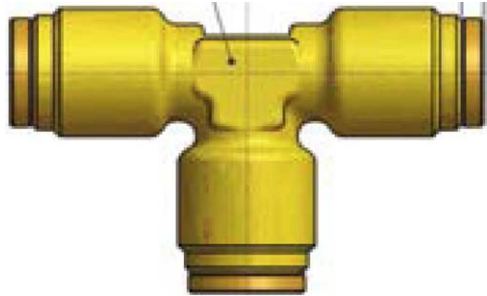

### BRASS FITTINGS

“Push - To - Connect”

Part #	Tube O.D.
AQ64-DOT-4	1/4"
AQ64-DOT-6	3/8"
AQ64-DOT-8	1/2"



Part #	Tube O.D.
AQ62-DOT-4	1/4"
AQ62-DOT-6	3/8"
AQ62-DOT-8	1/2"

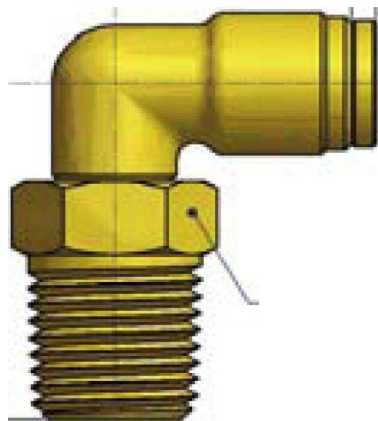

Part #	Tube O.D.	Thread
AQ69-DOTS-4X2	1/4"	1/8"
AQ69-DOTS-4X4	1/4"	1/4"
AQ69-DOTS-4X6	1/4"	3/8"
AQ69-DOTS-6X2	3/8"	1/8"
AQ69-DOTS-6X4	3/8"	1/4"
AQ69-DOTS-6X6	3/8"	3/8"
AQ69-DOTS-6X8	3/8"	1/2"
AQ69-DOTS-8X4	1/2"	1/4"
AQ69-DOTS-8X6	1/2"	3/8"
AQ69-DOTS-8X8	1/2"	1/2"
AQ69-DOTS-10X8	5/8"	1/2"

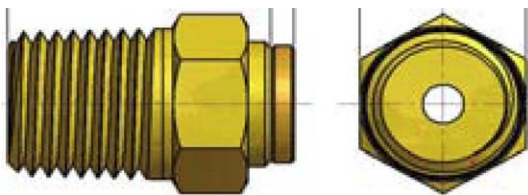

Part #	Tube O.D.	Thread
AQ68-DOTS-4X2	1/4"	1/8"
AQ68-DOTS-4X4	1/4"	1/4"
AQ68-DOTS-6X4	3/8"	1/4"
AQ68-DOTS-6X6	3/8"	3/8"
AQ68-DOTS-6X8	3/8"	1/2"
AQ68-DOTS-8X4	1/2"	1/4"
AQ68-DOTS-8X6	1/2"	3/8"
AQ68-DOTS-8X8	1/2"	1/2"
AQ68-DOTS-10X6	5/8"	3/8"
AQ68-DOTS-10X8	5/8"	1/2"



# CENTRAL HYDRAULICS INC.

•Daytona Beach •Cocoa •Leesburg •Ocala •Tampa 1-800-264-9571

## Camlocks



Size	Part #
<b>A</b>	
1/2"	A050-A
3/4"	A075-A
1"	A100-A
1-1/4"	A125-A
1-1/2"	A150-A
2"	A200-A
2-1/2"	A250-A
3"	A300-A
4"	A400-A
5"	A500-A
6"	A600-A
8"	A800-A



Size	Part #
<b>B</b>	
1/2"	B050-A
3/4"	B075-A
1"	B100-A
1-1/4"	B125-A
1-1/2"	B150-A
2"	B200-A
2-1/2"	B250-A
3"	B300-A
4"	B400-A
5"	B500-A
6"	B600-A
8"	B800-A



Size	Part #
<b>C</b>	
1/2"	C050-A
3/4"	C075-A
1"	C100-A
1-1/4"	C125-A
1-1/2"	C150-A
2"	C200-A
2-1/2"	C250-A
3"	C300-A
4"	C400-A
5"	C500-A
6"	C600-A
8"	C800-A



Size	Part #
<b>D</b>	
1/2"	D050-A
3/4"	D075-A
1"	D100-A
1-1/4"	D125-A
1-1/2"	D150-A
2"	D200-A
2-1/2"	D250-A
3"	D300-A
4"	D400-A
5"	D500-A
6"	D600-A
8"	D800-A



Size	Part #
<b>E</b>	
1/2"	E050-A
3/4"	E075-A
1"	E100-A
1-1/4"	E125-A
1-1/2"	E150-A
2"	E200-A
2-1/2"	E250-A
3"	E300-A
4"	E400-A
5"	E500-A
6"	E600-A
8"	E800-A



Size	Part #
<b>F</b>	
1/2"	F050-A
3/4"	F075-A
1"	F100-A
1-1/4"	F125-A
1-1/2"	F150-A
2"	F200-A
2-1/2"	F250-A
3"	F300-A
4"	F400-A
5"	F500-A
6"	F600-A
8"	F800-A



# CENTRAL HYDRAULICS INC.

•Daytona Beach •Cocoa •Leesburg •Ocala •Tampa 1-800-264-9571

## Camlocks



Size	Part #
<b>V</b>	
1/2"	V050-A
3/4"	V075-A
1"	V100-A
1-1/4"	V125-A
1-1/2"	V150-A
2"	V200-A
2-1/2"	V250-A
3"	V300-A
4"	V400-A
5"	V500-A
6"	V600-A
8"	V800-A



Size	Part #
<b>W</b>	
1/2"	W050-A
3/4"	W075-A
1"	W100-A
1-1/4"	W125-A
1-1/2"	W150-A
2"	W200-A
2-1/2"	W250-A
3"	W300-A
4"	W400-A
5"	W500-A
6"	W600-A
8"	W800-A

### KING NIPPLE



Size	Part #
<b>NPT</b>	
1/2"	ST1
3/4"	ST5
1"	ST10
1-1/4"	ST15
1-1/2"	ST20
2"	ST25
2-1/2"	ST30
3"	ST35
4"	ST40
6"	ST60
8"	ST80



### SUCTION STRAINER

Size	Part #
<b>NPT</b>	
1-1/2"	RHS150
2"	RHS200
2-1/2"	RHS250
3"	RHS300
4"	RHS400
6"	RHS600

### PLATED IRON MALE PIN LUG



Size	Part #
<b>NPSH</b>	
1-1/4"	S15
1-1/2"	S20
2"	S25
2-1/2"	S30
3"	S35
4"	S40



### PLATED IRON FEMALE PIN LUG

Size	Part #
<b>NPSH</b>	
1-1/4"	S17
1-1/2"	S22
2"	S27
2-1/2"	S32
3"	S38
4"	S42

Size	Part #
<b>NST</b>	<b>STEEL</b>
1-1/2"	S201
2-1/2"	S301

Size	Part #
<b>NST</b>	<b>STEEL w/ IRON NUT</b>
1-1/2"	S22N
2-1/2"	S32N

# CENTRAL HYDRAULICS INC.

•Daytona Beach •Cocoa •Leesburg •Ocala •Tampa 1-800-264-9571

## Fuel Nozzles and Accessories



**337004**  
18 GPM  
for 12v pumps



**159404**  
10GPM  
Unleaded



### 3/4" Automatic Shut-off



**2273**  
Disposable  
Breakaway



**3360**  
Reuseable  
Breakaway



**0350**  
3/4" Z  
Swivel

### 1" Automatic Shut-off



**173310**  
75GPM  
Diesel 45psi



**045704**  
15GPM  
Unleaded



**2276**  
Reuseable  
Breakaway



**0087**  
1" Z Swivel

### 1.5" Automatic Shut-off



**169010**  
100 GPM  
45psi



**3/4" or 1"**  
custom length  
curb pump hoses



**1", 1-1/4", 1-1/2"**  
Diesel fuel oil  
hose with custom  
lengths made.

# CENTRAL HYDRAULICS INC.

•Daytona Beach •Cocoa •Leesburg •Ocala •Tampa 1-800-264-9571

## Hose Reels



### Alemite Heavy Duty Reels



#### Oil Reel #8078-D

With hose type:  
1/2" x 50' (1,500psi)

#### Grease Reel #8078-B

With hose type:  
1/4" x 50' (5,000psi)

#### Air/Water Reel #8078-F

With hose type:  
3/8" x 50' (200psi)

#### Air/Water Reel #8078-M

With hose type:  
1/2" x 50' (200psi)



# CENTRAL HYDRAULICS INC.

•Daytona Beach •Cocoa •Leesburg •Ocala •Tampa 1-800-264-9571

## Diaphragm Pumps



### 1:1 Air Powered Double Diaphragm Pumps

1/4" 8301 Alemite 4gpm

3/8" 7gpm Free Flow Rate

Acetal Plastic Housing / Hytrel Diaphragm

Graco-Part # - D31255

1/2" 8322 Alemite 15gpm

Applications:

- Oil Transfer
- Water / Anti-freeze
- Windshield Washer Fluid

3/4" 16gpm Free Flow Rate

Aluminum Housing / Buna N Diaphragm

Graco- Part # - 241906

Applications:

- Oil Transfer
- Oil Evacuation
- Water / Anti-freeze
- Windshield Washer Fluid

1" 40gpm Free Flow Rate

Aluminum Housing / Hytrel Diaphragm

Graco- Part # - 647666

1" #8323 Alemite 45gpm Buna

Applications:

- Oil Transfer
- Oil Evacuation
- Water / Anti-freeze

1" 40gpm Free Flow Rate

Aluminum Housing / Hytrel Diaphragm

Graco- Part # - 647016

1" #8325 Alemite 45gpm Buna UL Listed

Applications:

- Diesel Fuel Transfer
- Oil Evacuation
- Water / Anti-freeze
- Harder Check Balls for Thermal Expansion

1.5" 90gpm Free Flow Rate

Aluminum Housing / Hytrel Diaphragm

Graco- Part # - DB3525

1" #8324 Alemite 106gpm Buna

Applications:

- Oil Transfer
- Oil Evacuation
- Water / Anti-freeze

### Accessories:

55 Gallon Drum  
Adapter  
DTBUSHING



Air Regulator  
109075



Telescoping  
Suction Tube  
100KTG8127

# CENTRAL HYDRAULICS INC.

•Daytona Beach •Cocoa •Leesburg •Ocala •Tampa 1-800-264-9571

## Clean Up Products

**Issue:** Potential safety hazards are present where leaks, drips, sprays or spills are most likely to occur.

**Solution:** A spill control plan should be developed with absorbent products readily available to control daily leaks and spills in and around your plant or to use in case of an emergency.

**Description:** Our premium clay absorbents undergo a superior moisture extraction process that increases absorption power and minimizes dust. Oil-Dri® Premium Absorbent is available in two types of packaging – poly bags and paper bags. Our paper bags are constructed of high performance multi-wall grade papers and our poly bags are made of heavy duty polyethylene.

### Features & Benefits:

- Versatile - Use for all non-aggressive fluids
- Superior Retention - Hold liquids in
- Strong - Won't breakdown and turn to mud
- Virtually Dust Free - Lower airborne contamination
- Low Density - More scoops per pound saves money

### Disposal Information:

Oil-Dri products must be disposed of in compliance with local, state and federal regulations. Since various fluids absorbed may be of toxic or hazardous in nature, Oil-Dri does not recommend disposal procedures.

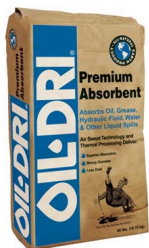

### OIL-DRI® PREMIUM ABSORBENTS - POLY BAGS

ITEM #	DESCRIPTION	PACKAGING
I06040-G50	40 lb. Poly Bag	50 bags/pallet
I05090-G40	50 lb. Poly Bag	40 bags/pallet
I18002-G50	40 lb. Poly Bag	50 bags/pallet

### OIL-DRI® PREMIUM ABSORBENTS - PAPER BAGS

ITEM #	DESCRIPTION	PACKAGING
I01040-G50	50 lb. Poly Bag	50 bags/pallet
I01050-G40	40 lb. Poly Bag	40 bags/pallet
I08030-G78	10 lb. Poly Bag	234 bags/pallet

# CENTRAL HYDRAULICS INC.

•Daytona Beach •Cocoa •Leesburg •Ocala •Tampa 1-800-264-9571

## Sample Hydraulic Systems

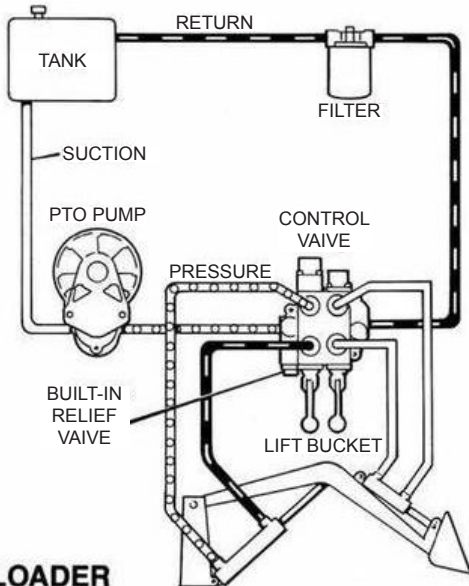

**LOADER**

The above system shows a front end loader powered by a PTO driven pump. A 2-spool directional control valve with built-in relief controls the lift and bucket cylinders of the loader. A return line filter is used to prevent contamination.

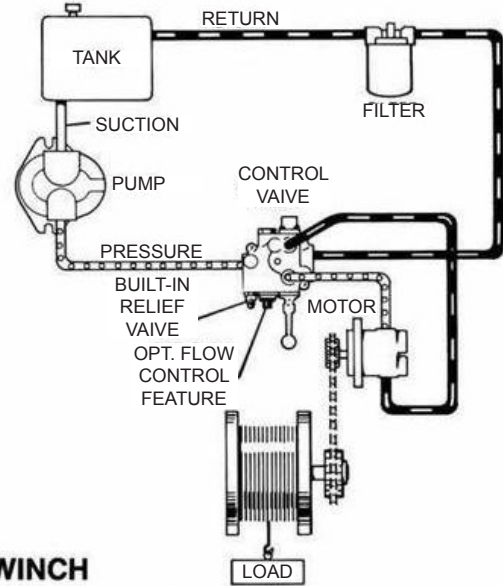

**WINCH**

The diagram shows a winch powered by a hydraulic motor. The directional control valve with built-in relief features optional flow control to control the speed of the winch. The hydraulic pump and motor must be matched to the torque requirements of the winch.

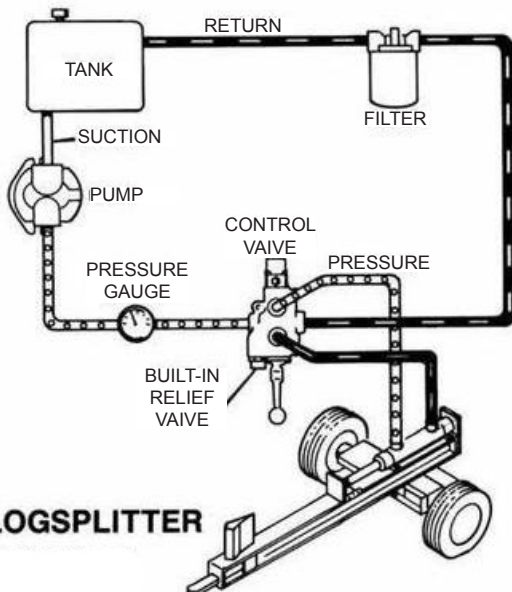

**LOGSPLITTER**

A directional control valve with optional pressure kickout feature controls a double acting cylinder. A pressure gauge is recommended to help spot potential system problems. The tank should be at least one and a half times the pump gpm output and the oil level must remain above the pump intake at all times.

### Useful Formulas

PSI	=	$\frac{\text{FORCE}}{\text{AREA}}$
CYL. AREA (sq. in.)	=	$\pi r^2$
FORCE (lbs.)	=	PSI x AREA
CYL. SPEED (ft. per second)	=	$\frac{.3208 \times \text{GPM}}{\text{AREA}}$
HORSE POWER	=	$\frac{\text{PSI} \times \text{GPM}}{1714}$
HORSE POWER (Fluid motor)	=	$\frac{\text{TORQUE}(\text{in. lbs.}) \times \text{RPM}}{63025}$
TORQUE (in lbs.)	=	$\frac{\text{PSI} \times \text{DISP.}(\text{cu.in.})}{2 \pi}$
RPM	=	$\frac{231 \times \text{GPM}}{\text{DISP.}(\text{cu.in.})}$
GPM (pump outflow)	=	$\frac{\text{RPM} \times \text{DISP.}(\text{cu.in.})}{231}$

# CENTRAL HYDRAULICS INC.

•Daytona Beach •Cocoa •Leesburg •Ocala •Tampa 1-800-264-9571

## Hydraulic Oil



**5 Gallon Pail**

Part #	Oil Type
AW325	5 GAL 5 WT HYD OIL
AW465	5 GAL 10 WT HYD OIL
AW685	5 GAL 20 WT STANDARD HYD OIL
AW1005	5 GAL 30 WT HYD OIL
UTF5	5 GAL UNIVERSAL TRACTOR FLUID
UTF-ULT5	5 GAL JD20 TRACTOR FLUID
DEX5	5 GAL DEXTRON 3
BIO5	5 GAL BIODEGRADABLE HYD OIL
DTE13M5	5 GAL NON CONDUCTIVE AERIAL FLUID
UTF-ULT5	5 GAL J20C UTF OIL



**55 Gallon Drum**

Part #	Oil Type
AW4655	55 GAL 10 WT HYD OIL
AW6855	55 GAL 20 WT HYD OIL
UTF55	55 GAL UNIVERSAL TRACTOR FLUID
BIO55	55 GAL BIODEGRADABLE HYD OIL

# CENTRAL HYDRAULICS INC.

•Daytona Beach •Cocoa •Leesburg •Ocala •Tampa 1-800-264-9571

## Fuel Transfer Pumps

**FILL-RITE.**



Model FR1210C

15 GPM

12 Volt DC  
Rotary Vane Pump

**P/N FR1210C**

- 1/4 H.P. 20 amp motor
- U/L listed
- Cast iron bump housing
- 1" inlet 3/4" outlet with a 2" tank adapter

15  
GPM

### Included In Box:

- Pump
- Owners Manual
- Pipe Fiting
- Teflon tape
- Steel telescoping suction tube
- 3/4" Manual nozzle
- 18' power cable
- 3/4" X 12' static guard hose

### Typical Application

- Diesel fuel
- Gasoline
- Kerosene
- Mineral spirits
- Stoddard solvents
- Heptane

### Optional Accessories:

Filter Element  
CIM 70002



Filter Head  
CIM 50003



3/4" Z Swivel  
0350



FR807C



FR901

3/4" Automatic  
Shut off nozzle  
337004





# CENTRAL HYDRAULICS INC.

•Daytona Beach •Cocoa •Leesburg •Ocala •Tampa 1-800-264-9571

## Fuel Transfer Pumps

**FILL-RITE.**



Model FR4210

20 GPM

DC High Flow Pump

12 Volt DC  
Rotary Vane Pump

**P/N FR4210**

- 1/4 H.P. 22 amp motor
- U/L listed
- Cast iron bump housing
- 1" inlet 1" outlet with a 2" tank adapter

20  
GPM

### Included In Box:

- Pump
- Owners Manual
- Pipe Fitting
- Teflon tape
- Steel telescoping suction tube
- 1" Manual nozzle
- 18' power cable
- 1" X 12' static guard hose

### Typical Application

- Diesel fuel
- Gasoline
- Kerosene
- Mineral spirits
- Stoddard solvents
- Heptane

### Optional Accessories:

Filter Element  
CIM 70002



Filter Head  
CIM 50002



1" Z Swivel  
0087



FR807C



FR901

1" Automatic  
Shut off nozzle  
045704



# CENTRAL HYDRAULICS INC.

•Daytona Beach •Cocoa •Leesburg •Ocala •Tampa 1-800-264-9571

## Fuel Transfer Pumps

**FILL-RITE.**



Model FR700

20 GPM

AC Utility Rotary Vane Pump

115 Volt AC High Flow  
Rotary Vane Pump

**P/N FR700**

- 1/3 H.P.
- U/L listed
- Cast iron bump housing
- 1" inlet 3/4" outlet with a 2" tank adapter

**20  
GPM**

### Included In Box:

- Pump
- Owners Manual
- 2" Tank Adapter
- Teflon tape
- Steel telescoping suction tube
- 3/4" Manual nozzle
- 3/4" X 12' static guard hose

### Typical Application

- Diesel fuel
- Gasoline
- Kerosene
- Mineral spirits
- Stoddard solvents
- Heptane

### Optional Accessories:

Filter Element  
CIM 70002



Filter Head  
CIM 50003

3/4" Z Swivel  
0350



FR807C



FR901

3/4" Automatic  
Shut off nozzle  
337004



# CENTRAL HYDRAULICS INC.

•Daytona Beach •Cocoa •Leesburg •Ocala •Tampa 1-800-264-9571

## Fuel Transfer Pumps

**FILL-RITE.**



Model FR152

Piston Hand Pump

**Piston Hand Pump**  
20gal per 100 strokes

### P/N FR152

- U/L listed
- Aluminum body with stainless steel liner
- 1" inlet 3/4" outlet with a 2" tank adapter

- Pump
- Owners Manual
- 2" Tank Adapter
- Teflon tape
- Steel telescoping suction tube
- 3/4" nozzle
- 3/4" X 8' static guard hose

### Typical Application

- Diesel fuel
- Gasoline
- Kerosene
- Most non-corrosive
- Light Oils

### Optional Accessories:



3/4" Z Swivel  
0350



**NAS NS10**  
Filter Element  
with drain for  
gasoline and  
diesel fuel



# CENTRAL HYDRAULICS INC.

•Daytona Beach •Cocoa •Leesburg •Ocala •Tampa 1-800-264-9571

## Fuel Transfer Pumps

**FILL-RITE.**



Model FR112

Rotary Hand Pump

### Included In Box:

- Pump
- Owners Manual
- 2" Tank Adapter
- Teflon tape
- telescoping suction tube
- 3/4" nozzle
- 3/4" X 8' static guard hose
- Pipe fittings
- Water Deflector

**Rotary Hand Pump**  
10gal per 100 revolutions

### P/N FR112

- U/L listed
- Aluminum body with stainless steel liner
- 1" inlet 3/4" outlet with a 2" tank adapter

### Typical Application

- Diesel fuel
- Gasoline
- Kerosene
- Most non-corrosive
- Light Oils
- Motor Oils
- Hydraulic Oils
- Line Oils

### Optional Accessories:



3/4" Z Swivel  
0350



**NAS NS10**  
Filter Element  
with drain for  
gasoline and  
diesel fuel



# CENTRAL HYDRAULICS INC.

•Daytona Beach •Cocoa •Leesburg •Ocala •Tampa 1-800-264-9571

## Oil and Grease Pumps

### Oil Pump Specification

#### Fire-Ball 300, 5:1 Air-Operated Piston Pump

Cycles/gallon(cycles/liter).....	28.4(8.6)
Fluid flow @ 80cpm(gpm/lpm).....	2.8(9.3)
Maximum fluid pressure.....	900psi (62 bar, 6.2 MPa)
Air motor effective diameter.....	3in(76.2mm)
Air operating range.....	40-180 psi 2.8-12 bar (0.28-1.2 MPa)
Approx. air consumption and.....	27 scfm @ 3gpm
fluid flow @ 100psi air and 80 cpm	(0.765m <sup>3</sup> /min @ 115 lpm)
Wetted materials.....	Steel, polyurethane, aluminum, buna-N
Air inlet port size.....	3/8npt(f)
Fluid inlet port size.....	1-1/2 npt(f)
Fluid outlet port size.....	1/2 npt(f)
Instruction manual.....	309869

#### Typical Fluids Handled

\*Grease up to NGLI #2

### Grease Pump Specification

#### Fire-Ball 300, 50:1 Air-Operated Piston Pump

Maximum Fluid Pressure.....	8400psi (580 bar)
Air motor effective diameter.....	3in (76.2mm)
Operating range.....	30-140psi (3.0-9.7 bar)
Continuous duty flow rate.....	1.19lb/min
Approx. air consumption @100psi (7 bar).....	22.8cfm
Air inlet.....	3/8 npt(f)
Material outlet.....	1/4 npt(f)
Material inlet.....	slotted
Wetted Parts.....	CS, Delrin, Buna-N, Polyurethane
Instruction Manual.....	300883

#### Typical Fluids Handled

\*Petroleum and synthetic based oils

#### Pump Performance

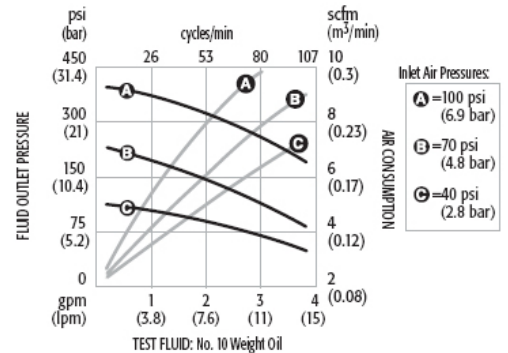

#### Pump Performance

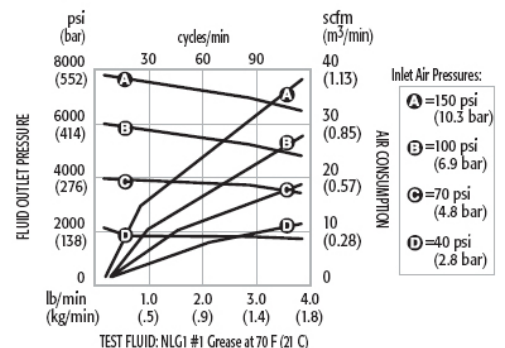

# CENTRAL HYDRAULICS INC.

•Daytona Beach •Cocoa •Leesburg •Ocala •Tampa 1-800-264-9571

## Pump for Oil/ATF/Gear Lube

Key Applications  
Fluid oil transfer to multiple metered dispense points.

Key Materials

- Motor oil
- Synthetic oil
- Hydraulic oil
- Gear oil
- ATF

Recommended For

- Service Shops
- Construction Equip. Maintenance
- Service Shops
- Fast Lubes
- Fleet

### 5:1 55gal or 275gal Bung Mounted

Air operated from 40psi to 180psi



Perfect for high pressure fluid oil transfer in medium volume applications! This pump has been the 'crown jewel' of Graco since the 1950's and is the pump of choice in the most demanding environments.

Features and Benefits

- Corrosion-resistant design utilizes liquid salt nitriding, nickel plating, stainless steel, aluminum and chrome on key components for longer life.
- Few moving parts in the air motor assembly means less downtime and low repair cost.
- Displacement rods have minimal wear due to a proprietary Graco manufacturing process.
- Large air porting design provides efficient use of compressed air supply for continuous pump operation without icing.
- Thick cast aluminum air motor housing offers unmatched durability.

### Non-Metered Valves



**ALE 7492**  
Gear Oil

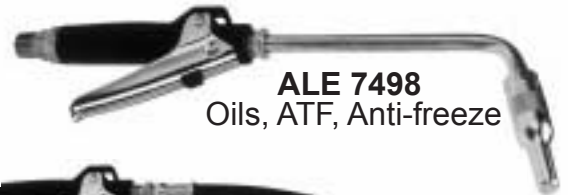

**ALE 7498**  
Oils, ATF, Anti-freeze



**ALE 7498-A**  
Oils, ATF, Anti-freeze

### Metered Valves



**ALE 3685-F**  
Mechanical



**3670-B**  
Digital



**8078-D**



Hose Reels

with 1/2" x 50FT  
Fluid Hose Assy.

* = included in package	Bung-Mounted pkg.	Bung-Mounted pkg.
Container Size	55gal	275gal
Package No.	225640*	225931*
Pump	204254*	222087
Dispense/Hose Fitting Kit	222063*	222063
Fluid Hose	6ft x 1/2in*	6ft x 1/2in
Air Hose	6ft x 3/8in*	6ft x 3/8in
Air Regulator( <i>with gauge</i> )	109075 ( <i>optional</i> )	109075
Bung Adapter	222308*	222308

Fax: 386-257-5728 Tele. 1-800-264-9571 sales@centralhydraulics.com www.centralhydraulics.com

# CENTRAL HYDRAULICS INC.

•Daytona Beach •Cocoa •Leesburg •Ocala •Tampa 1-800-264-9571

## Stub Pump for bulk oil

### 5:1 Air Operated from 40psi to 180psi

#### Key Applications

Fluid oil transfer to multiple metered dispense points.

#### Key Materials

- Motor oil
- Synthetic oil
- Hydraulic oil
- Gear oil
- ATF

#### Recommended For

- Service Shops
- Construction Equip. Maintenance
- Service Shops
- Fast Lubes
- Fleet

Perfect for high pressure fluid oil transfer in medium volume applications! This pump has been the 'crown jewel' of **Graco** since the 1950's and is the pump of choice in the most demanding environments.

#### Features and Benefits

- Corrosion-resistant design utilizes liquid salt nitriding, nickel plating, stainless steel, aluminum and chrome on key components for longer life.
- Few moving parts in the air motor assembly means less downtime and low repair cost.
- Displacement rods have minimal wear due to a proprietary Graco manufacturing process.
- Large air porting design provides efficient use of compressed air supply for continuous pump operation without icing.
- Thick cast aluminum air motor housing offers unmatched durability.



#### Stub Pump

203876 Fire-Ball 300,  
5:1 pump universal

#### Suction Adapters

SVF HB150X100 1-1/2" to 1"  
Bushing

LIN DTBUSHING Tank bushing  
for telescoping tube

TUT 100KTG-8127 Telescoping  
suction tube

#### Optional Accessories

109075 3/8" Air regulator/gauge

222308 2" bung adapter

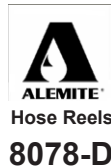

8078-D  
with 1/2" x 50FT  
Fluid Hose Assy.



#### Metered Valves



238461  
Digital



3685-F  
Mechanical



ALE 7498-A  
Oils, ATF, Anti-freeze



ALE 7492  
Gear Oil



222413  
ATF

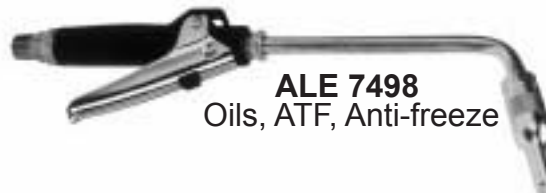

ALE 7498  
Oils, ATF, Anti-freeze

# CENTRAL HYDRAULICS INC.

•Daytona Beach •Cocoa •Leesburg •Ocala •Tampa 1-800-264-9571

## Pump for Grease (35lbs)

### 50:1 For 5 Gallon (35lbs) Container

Air operated from 30psi to 140psi

#### Key Applications

High-pressure grease dispense

#### Key Materials

- NLGI #00 Grease
- NLGI #0 Grease
- NLGI #1 Grease
- NLGI #2 Grease

#### Recommended For

- Service Shops
- Construction Equip. Maintenance
- Service Shops
- Automotive Dealerships
- Fast Lubes
- Fleet

#### Perfect for high pressure grease dispense!

Graco's Fire-Ball pumps are built to last. For almost 50 years the Fire-Ball 300, 50:1 ratio has been a mainstay in the lubrication marketplace for its durability and long life. A package including a trusty Fire-Ball is sure to last!

#### Features and Benefits

- Corrosion-resistant design utilizes liquid salt nitriding, nickel plating, stainless steel, aluminum and chrome on key components for longer life.
- Few moving parts in the air motor assembly means less downtime and low repair cost.
- Displacement rods have minimal wear due to a proprietary Graco manufacturing process.
- Large air porting design provides efficient use of compressed air supply for continuous pump operation without icing.
- Thick cast aluminum air motor housing offers unmatched durability.



<b>Container Size 35lbs</b>	
Package No.	222069*
Pump No.	239877*
Dispense Kits	222070*
Fluid Hose	12ft x 1.4in*
Control Handle	242056*
Z Swivel	202577*
Follower Plate	220653*
Cover	222059*

\* = included in package

<b>Optional Accessories</b>	
Air regulator with gauge	109075
Flex Hose for gun	5812
Hose Reel	8078-B



Regulator & Gauge  
109075



8078-B

with 1/4" x 50ft Grease  
Hose Assy.



Hose Reels



# CENTRAL HYDRAULICS INC.

•Daytona Beach •Cocoa •Leesburg •Ocala •Tampa 1-800-264-9571

## Pump for Grease (120lbs)

### 50:1 For 120lb Containers

Air operated from 30psi to 140psi

#### Key Applications

High-pressure grease dispense

#### Key Materials

- NLGI #00 Grease
- NLGI #0 Grease
- NLGI #1 Grease
- NLGI #2 Grease

#### Recommended For

- Service Shops
- Construction Equip. Maintenance
- Service Shops
- Automotive Dealerships
- Fast Lubes
- Fleet



#### Perfect for high pressure grease dispense!

Graco's Fire-Ball pumps are built to last. For almost 50 years the Fire-Ball 300, 50:1 ratio has been a mainstay in the ubrication marketplace for its durability and long life. A package including a trusty Fire-Ball is sure to last!

#### Features and Benefits

- Corrosion-resistant design utilizes liquid salt nitriding, nickel plating, stainless steel, aluminum and chrome on key components for longer life.
- Few moving parts in the air motor assembly means less downtime and low repair cost.
- Displacement rods have minimal wear due to a proprietary Graco manufacturing process.
- Large air porting design provides efficient use of compressed air supply for continuous pump operation without icing.
- Thick cast aluminum air motor housing offers unmatched durability.

<b>Container Size 120lbs</b>	
Package No.	225014*
Pump No.	239887*
Dispense Kits	222072*
Fluid Hose	6ft x 1/4in*
Air Hose	6ft x 3/8in*
Follower Plate	220654*
Cover	204574*

\* = included in package

<b>Optional Accessories</b>	
Air regulator with gauge	109075
Flex Hose for gun	5812
Control Handle	242056
Z Swivel	202577
Hose Reel	8078-B



Pro Shot Grease Gun  
242056



Regulator & Gauge  
109075



Z Swivel  
202577



8078-B



Hose Reels

with 1/4" x 50ft Grease Hose Assy.

# CENTRAL HYDRAULICS INC.

•Daytona Beach •Cocoa •Leesburg •Ocala •Tampa 1-800-264-9571

## Pump for Grease(400lbs)

### 50:1 For 400lb Containers

Air operated from 30psi to 140psi

#### Key Applications

High-pressure  
grease dispense

#### Key Materials

- NLGI #00 Grease
- NLGI #0 Grease
- NLGI #1 Grease
- NLGI #2 Grease

#### Recommended For

- Service Shops
- Construction Equip.  
Maintenance
- Service Shops
- Automotive Dealerships
- Fast Lubes
- Fleet



#### Perfect for high pressure grease dispense!

Graco's Fire-Ball pumps are built to last. For almost 50 years the Fire-Ball 300, 50:1 ratio has been a mainstay in the ubrication marketplace for its durability and long life. A package including a trusty Fire-Ball is sure to last!

#### Features and Benefits

- Corrosion-resistant design utilizes liquid salt nitriding, nickel plating, stainless steel, aluminum and chrome on key components for longer life.
- Few moving parts in the air motor assembly means less downtime and low repair cost.
- Displacement rods have minimal wear due to a proprietary Graco manufacturing process.
- Large air porting design provides efficient use of compressed air supply for continuous pump operation without icing.
- Thick cast aluminum air motor housing offers unmatched durability.

<b>Container Size 400lbs</b>	
Package No.	225016*
Pump No.	239888*
Dispense Kits	222072*
Fluid Hose	6ft x 1/4 in"
Air Hose	6ft x 3/8 in"
Follower Plate	223845*
Cover	200326*

\* = included in package

<b>Optional Accessories</b>	
Air regulator with gauge	109075
Flex Hose for gun	5812
Control Handle	242056
Z Swivel	202577
Hose Reel	8078-B



Pro Shot Grease Gun  
242056



Regulator & Gauge  
109075



Z Swivel  
202577



8078-B



Hose Reels

with 1/4" x 50ft Grease  
Hose Assy.

# CENTRAL HYDRAULICS INC.

•Daytona Beach •Cocoa •Leesburg •Ocala •Tampa 1-800-264-9571

## Manual Hose Reels



INLET - 1/2" FPT

### M Series Mini 3/8" and 1/2" Hose I.D.

Model Number	Operating Pressure	Capacity 3/8"	Hose I.D. 1/2"	Shipping Weight
M 5-5-14N	4000 PSI	75 FT.	50 FT.	20#
M 10-5-14	4000 PSI	150 FT.	100 FT.	23#

#### COMPACT MANUAL DRIVEN MINI-REEL.

REEL is best applied where a maximum of 150 ft. of 3/8" I.D. hose is required, and where space or weight is a critical factor. This products is ideally fitted into tight space applications such as small truck skid units for pesticides, pressure wash or deployment of air tools in the construction trades.

### Specifics

- Beaded edges on spool prevents hose damage or injury to operator
- Heavy 12 GA. base
- Heavy duty ABS bearings require no lubrication for years of dependable service
- Fully adjustable brake - adjust with hand knob
- Only 14 1/2" tall
- External swivel-O-rings can be changed by simply removing one retaining ring

M Series Mini Hose Reels also available in stainless steel. Call for more details.

# HOSETRACT

Fax: 386-257-5728 Tele. 1-800-264-9571 sales@centralhydraulics.com www.centralhydraulics.com

HOS-224-F-01

# CENTRAL HYDRAULICS INC.

•Daytona Beach •Cocoa •Leesburg •Ocala •Tampa 1-800-264-9571

## Manual Hose Reels

### M Series

### 3/8" and 1/2" Hose I.D.

Model Number	Operating Pressure	Capacity		Shipping Weight
		3/8"	1/2"	
M 5-5	4000 PSI	100 FT.	75 FT.	30#
M 10-5	4000 PSI	250 FT.	175 FT.	37#
M 15-5	4000 PSI	350 FT.	275 FT.	49#
M 20-5	4000 PSI	450 FT.	375 FT.	59#
M 25-5	4000 PSI	550 FT.	475 FT.	72#



INLET - 1/2" FPT

Guide system available for 10", 15", 20", 25" wide reels. Sold separately. M Series Hose Reels also available in stainless steel.

- Flow through shaft for universal installation
- Self lubricating ABS bearings
- External swivel - standardized O-rings can be changed by simply removing one retaining ring
- Fully adjustable nylon brake - adjust tension with hand knob
- Mounting base is light and strong



INLET - 1" FPT

### M Series

### 3/4" and 1" Hose I.D.

Model Number	Operating Pressure	Capacity		Shipping Weight
		3/4"	1"	
M 10-10	300 PSI	75 FT.	50 FT.	40#
M 15-10	300 PSI	100 FT.	75 FT.	49#
M 20-10	300 PSI	125 FT.	100 FT.	59#
M 25-10	300 PSI	150 FT.	125 FT.	72#

Guide system available for 10", 15", 20", 25" wide reels. Sold separately

- Flow through shaft for left or right hand installation
- Self lubricating ABS bearings
- External swivel - standardized O-rings can be changed by simply removing one retaining ring
- Fully adjustable nylon brake - adjust tension with hand knob
- Mounting base is light and strong

# HOSETRACT

# Central Hydraulics Inc.

*Specializing in wholesale and OEM sales  
of hydraulic hose, pumps, motors,  
cylinders, valves, & components*

1580 North Nova Road  
Daytona Beach, FL 32117

Toll Free: **1-800-264-9571**

Telephone: **386-253-2568**

Fax: **386-257-5728**

[www.CentralHydraulics.com](http://www.CentralHydraulics.com)  
[sales@centralhydraulics.com](mailto:sales@centralhydraulics.com)