

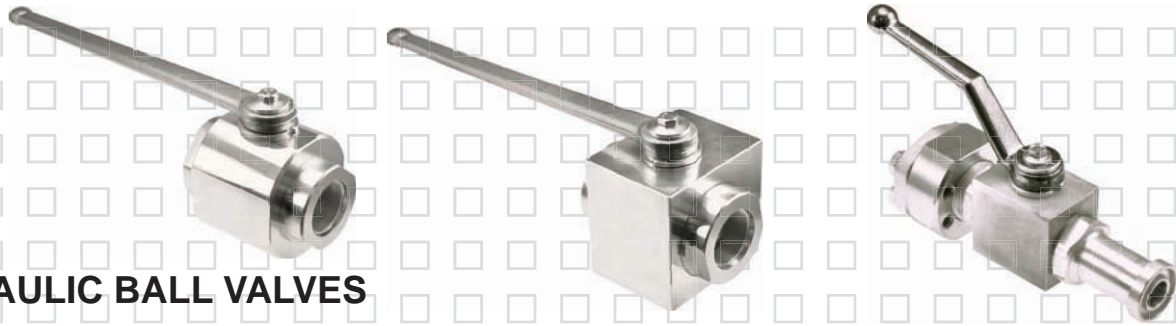

FLOW CONTROL, NEEDLE & CHECK VALVES

FLOW, NEEDLE & CHECK VALVES



HYDRAULIC BALL VALVES

HYDRAULIC BALL VALVES

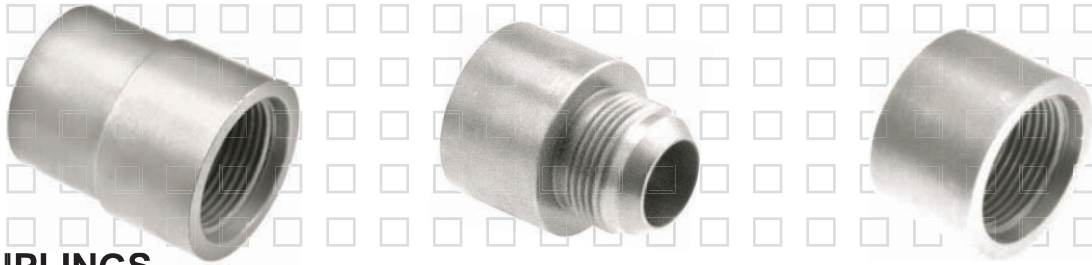

WELD COUPLINGS

WELD COUPLINGS

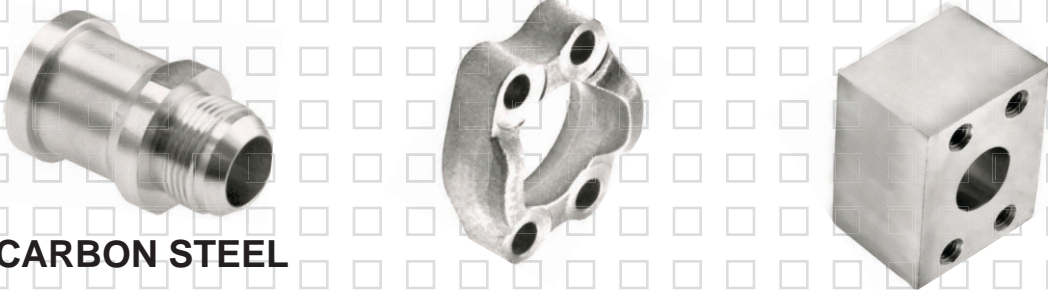

FLANGES - CARBON STEEL

FLANGES - CARBON STEEL

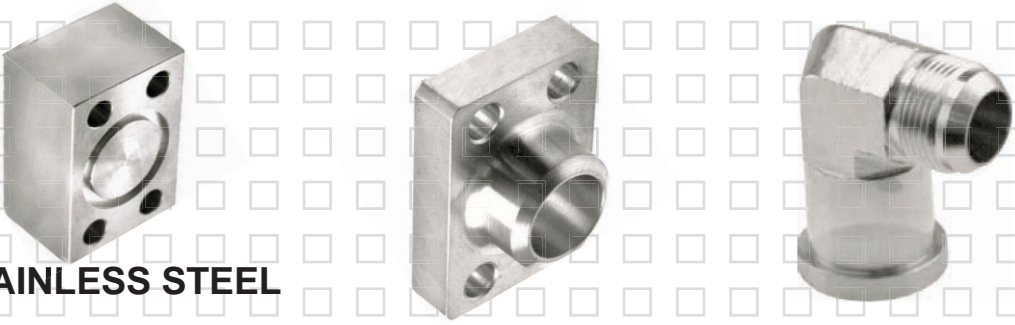

FLANGES - STAINLESS STEEL

FLANGES - STAINLESS STEEL





Carbon Steel Check Valves _____	4
Carbon Steel Flow Control Valves _____	6
Carbon Steel Needle Valves _____	8



NPTF & SAE Connections
 Carbon Steel with Zinc Chromate Plating (RoHS Compliant)
 Available in 7 PSI & 65 PSI Spring Cracking Pressures
 Metal to Metal Seat
 Hardened Poppet
 Temperature Range -4°F to +176°F

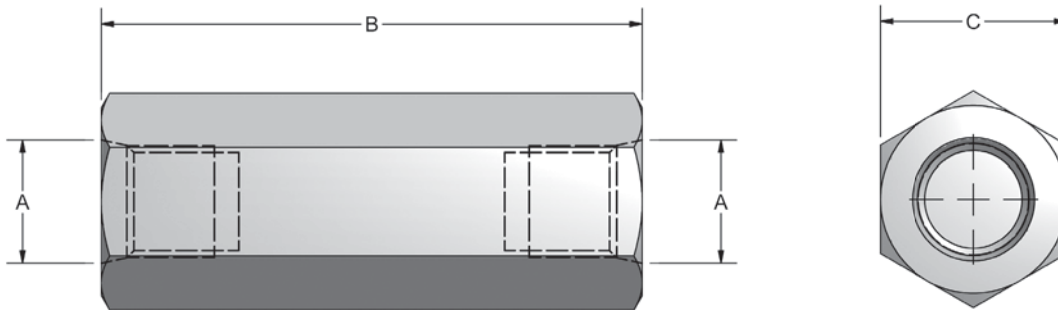
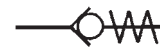

CHECK VALVES						
A		B	C	MAX PSI	MAX FLOW GPM	WEIGHT (LBS)
NPTF	SAE					
1/4"	#4	2.17	.75	5700	4	.2
3/8"	N/A	2.68	.95	5700	8	.4
N/A	#6	2.28	.75	5700	8	.2
1/2"	N/A	2.95	1.06	5700	13	.5
N/A	#8	2.72	.95	5700	13	.4
3/4"	#12	3.48	1.38	5700	23	1.0
1"	#16	4.33	1.61	5000	40	1.6
1 1/4"	#20	4.72	2.17	5000	50	3.4
1 1/2"	#24	5.43	2.56	5000	80	5.6
2"	#32	5.43	2.95	4500	110	6.7

Model Code Breakdown

C N 1/2 - 1 - 7

Valve Series

Thread Type

N	NPTF Pipe Thread
S#	SAE Straight Thread

Thread Size

Example	N1/2
	S#8

Cracking Pressure

7	7 PSI
65	65 PSI

Material

1	Carbon Steel
---	--------------

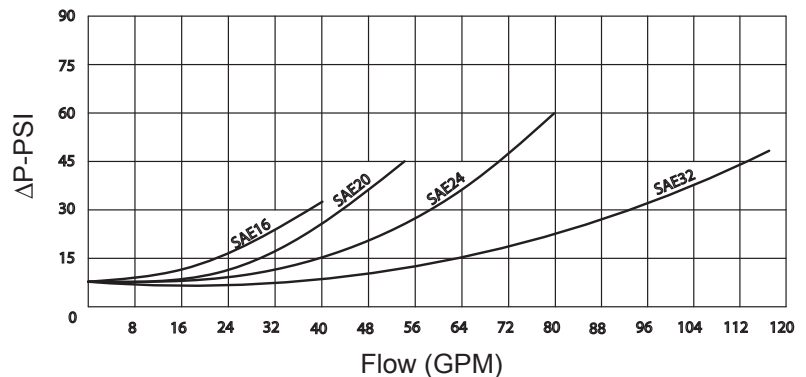
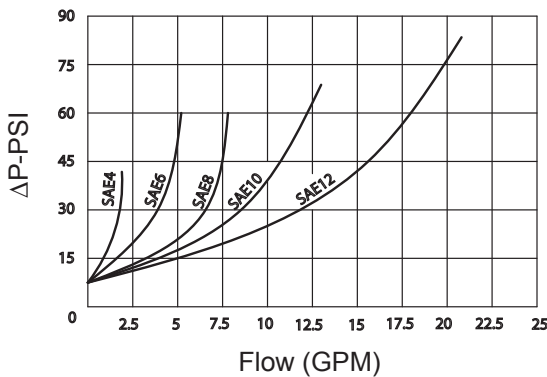
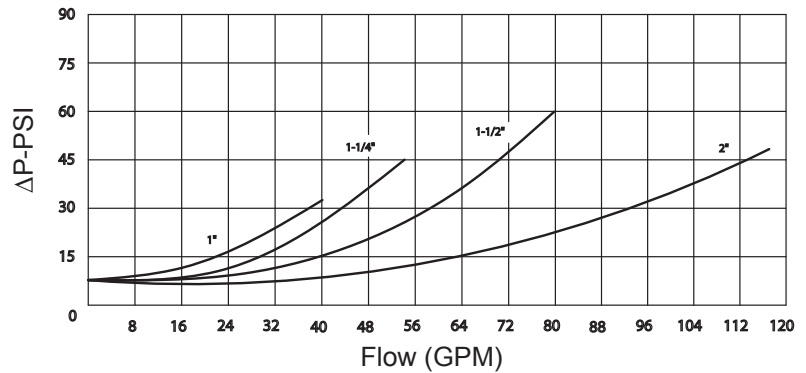
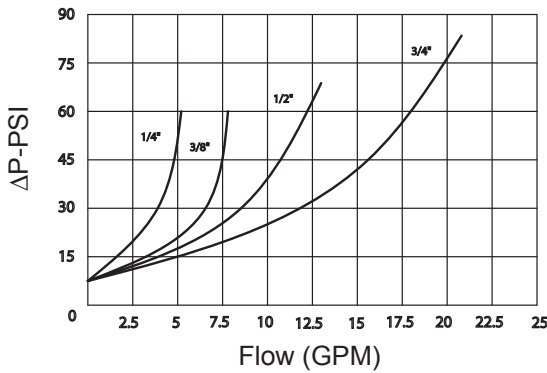



NPTF & SAE Connections
 Carbon Steel with Zinc Chromate Plating (RoHS Compliant)
 Set Screw Allows Knob to be Locked into Position
 Graduated Knob & Spindle for Accurate Flow Control
 7 PSI Standard Spring Setting
 Buna O-Ring / PTFE Stem Packing
 Temperature Range -4°F to +176°F

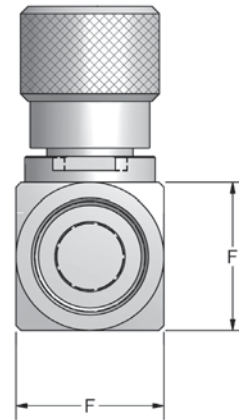
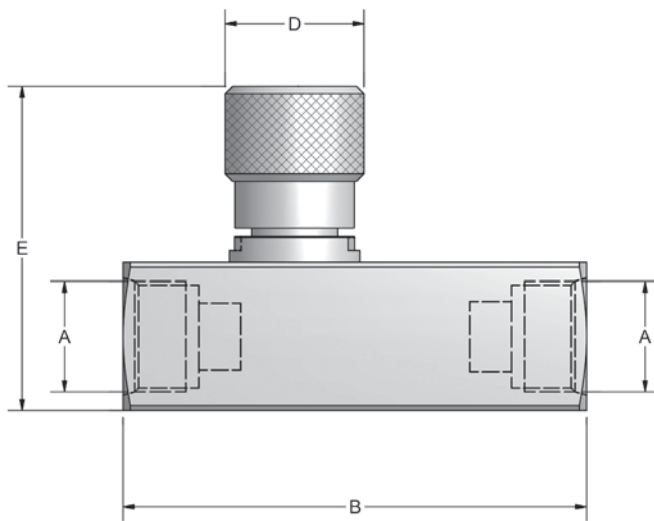
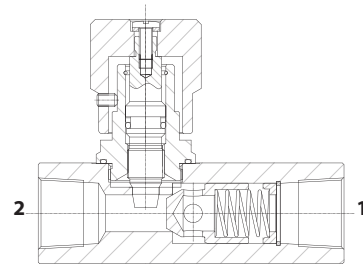
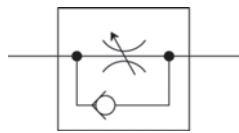

FLOW CONTROL VALVES								
A		B	D	E	F	MAX PSI	MAX FLOW GPM	WEIGHT (LB)
NPTF	SAE							
1/4	#4	2.60	1.18	2.67	0.98	5700	4	0.83
3/8	#6	3.00	1.18	2.67	0.98	5700	8	0.86
1/2	#8	3.58	1.29	2.79	1.18	5700	13	1.4
3/4	#12	4.43	1.65	3.70	1.57	5700	21	3.0
1	#16	5.55	1.65	3.93	1.77	5700	40	4.2
1-1/4	#20	6.10	2.08	4.78	2.16	4000	50	7.0
1-1/2	#24	6.61	2.08	5.17	2.55	4000	80	10.0

Model Code Breakdown

F N 1/2 - 1

Valve Series

Thread Type

N	NPTF Pipe Thread
S#	SAE Straight Thread

Material

1	Carbon Steel
---	--------------

Thread Size

Example	N1/2
	S#8

NPTF

SAE

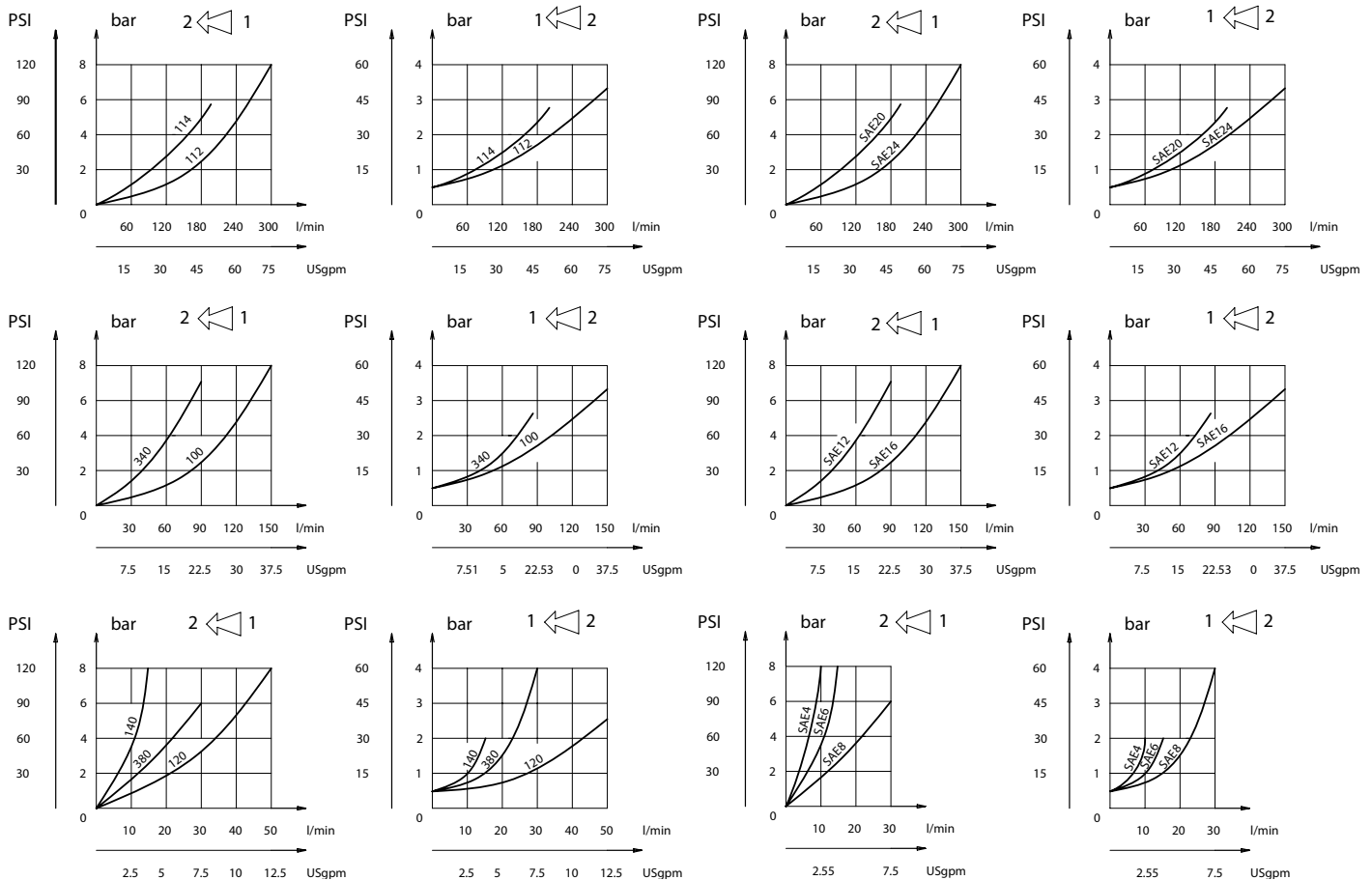



NPTF & SAE Connections
 Carbon Steel with Zinc Chromate Plating (RoHS Compliant)
 Set Screw Allows Knob to be Locked into Position
 Graduated Knob & Spindle for Accurate Flow Control
 Buna O-Ring / PTFE Stem Packing
 Temperature Range -4°F to +176°F

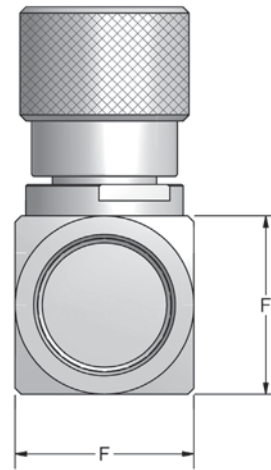
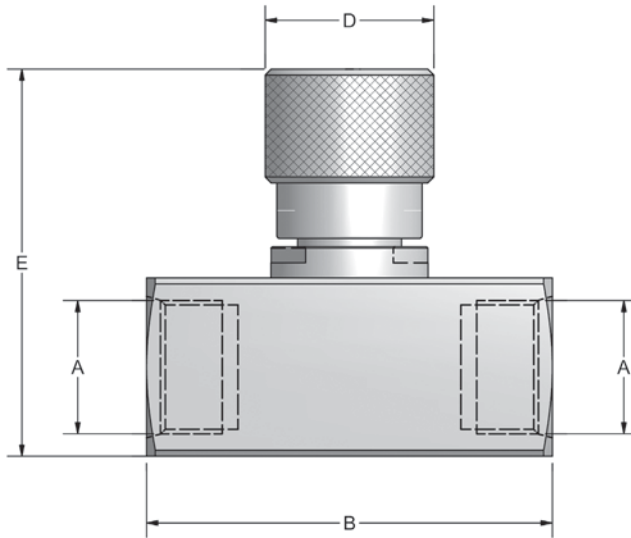
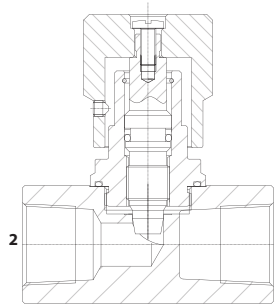
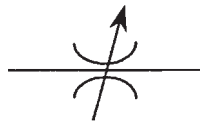

NEEDLE VALVES								
A		B	D	E	F	MAX PSI	MAX FLOW GPM	WEIGHT (LB)
NPTF	SAE							
1/4	#4	2.12	1.18	2.67	0.98	5700	4	0.70
3/8	#6	2.12	1.18	2.67	0.98	5700	8	0.66
1/2	#8	2.51	1.29	2.85	1.18	5700	13	1.0
3/4	#12	3.19	1.65	3.70	1.57	5700	21	2.3
1	#16	4.00	1.65	3.93	1.77	5700	40	3.2
1-1/4	#20	4.02	2.08	4.78	2.16	4000	50	5.0
1-1/2	#24	4.02	2.08	5.17	2.55	4000	80	6.5

Model Code Breakdown

N N 1/2 - 1

Valve Series

Thread Type

N	NPTF Pipe Thread
S#	SAE Straight Thread

Material

1	Carbon Steel
---	--------------

Thread Size

Example	N1/2
	S#8

NPTF

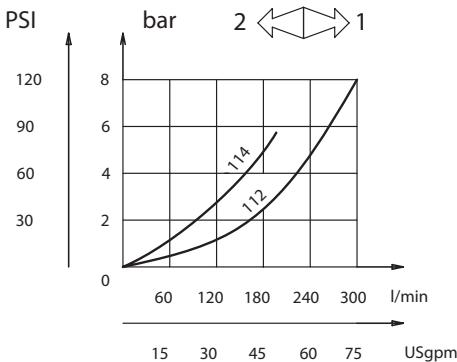
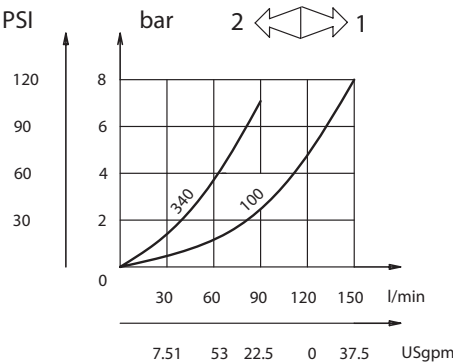
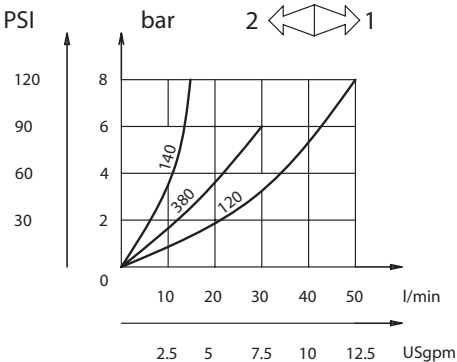

SAE

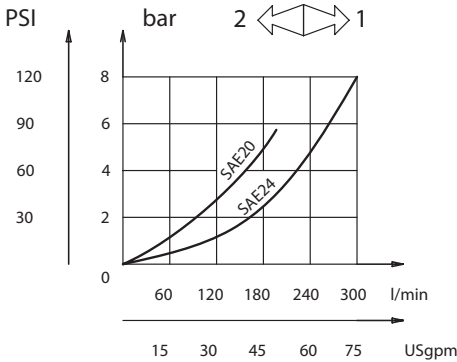
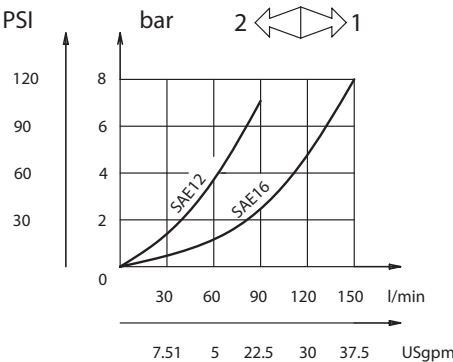
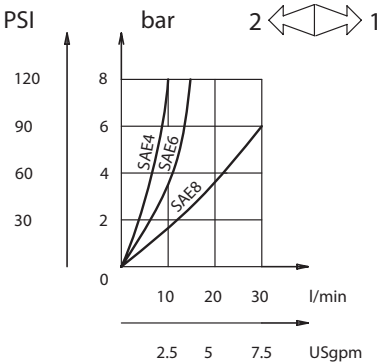



Notes

FLOW, NEEDLE & CHECK VALVES

HYDRAULIC BALL VALVES

WELD COUPLINGS

FLANGES - CARBON STEEL

FLANGES - STAINLESS STEEL

Lined area for notes



Notes

FLOW, NEEDLE & CHECK VALVES

HYDRAULIC BALL VALVES

WELD COUPLINGS

FLANGES - CARBON STEEL

FLANGES - STAINLESS STEEL

Lined area for notes



Lined area for notes

FLOW, NEEDLE & CHECK VALVES

HYDRAULIC BALL VALVES

WELD COUPLINGS

FLANGES - CARBON STEEL

FLANGES - STAINLESS STEEL

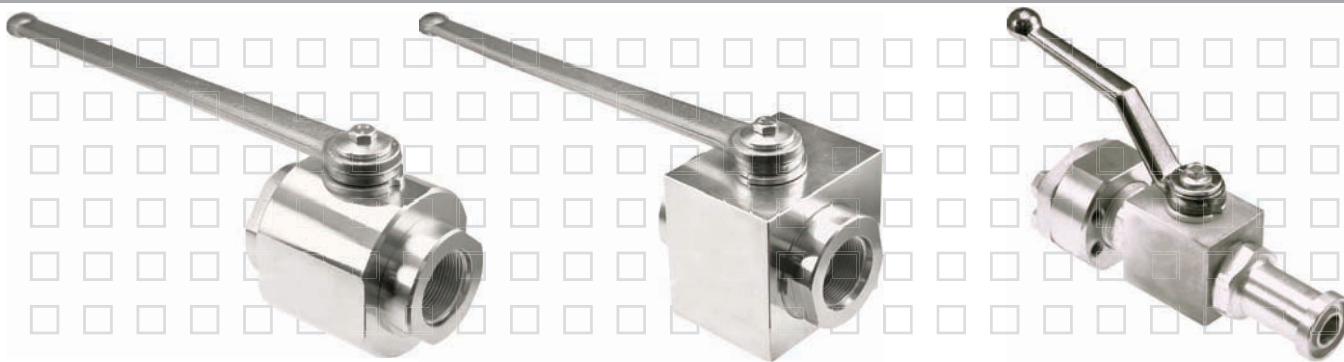



AE2 / Two-Way Block Body Threaded _____	16
AB2 / Two-Way Round Body Threaded _____	18
AV2 / Two-Way Excavator Style _____	20
AV3 / Three-Way Excavator Style _____	22
AE3 / Three-Way Block Body Threaded _____	24
AE3K / "True" Three-Way Block Body Threaded ____	26
AB3 / Three-Way Round Body Threaded _____	28
AES / Two-Way Block Body Flange Head _____	30
ABS / Two-Way Round Body Flange Head _____	32
AEF / Two-Way Block Body Flat Faced _____	34
ABF / Two-Way Round Body Flat Faced _____	36
AES/F & ABS/F / Two-Way Flange Head X Flat Face _	38
APK / Two-Way Manifold Mount _____	40
Locking Kits _____	42
Handles _____	43
LV2B / 1000 WOG Two-Way Stainless Steel _____	44
MV2B / 2000 WOG Two-Way Stainless Steel _____	45

BALL VALVE PRESSURE SPECIFICATIONS

Anchor Fluid Power ball valves are tested in accordance with API 598, Eighth Edition, May 2004 standards. End connections are manufactured in accordance with one or more of the following specifications.

- | | | | |
|--------------------|-------------------|-------------------|----------------------|
| SAE J1926/1 | SAE J518-1 | ISO 6162-1 | SAE J514 |
| SAE J1453/B | SAE J518-2 | ISO 6162-2 | ANSI B.1.20.1 |

FLOW, NEEDLE & CHECK VALVES
 HYDRAULIC BALL VALVES
 WELD COUPLINGS
 FLANGES - CARBON STEEL
 FLANGES - STAINLESS STEEL



FLOW, NEEDLE & CHECK VALVES

HYDRAULIC BALL VALVES

WELD COUPLINGS

FLANGES - CARBON STEEL

FLANGES - STAINLESS STEEL

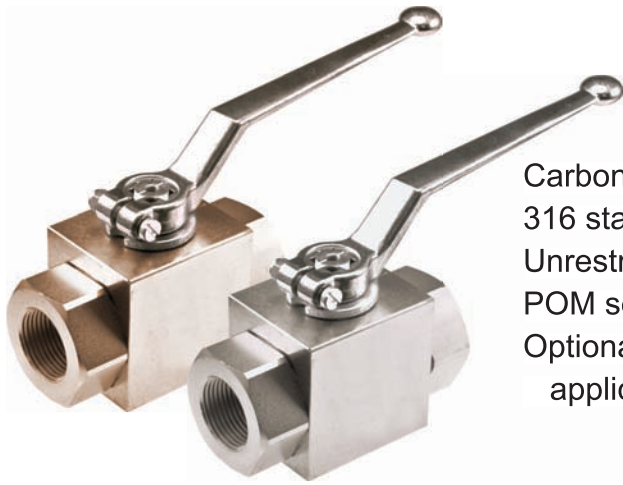

Carbon Steel with Zinc Chromate Plating (RoHS Compliant)
 316 stainless steel available from stock
 Unrestricted bore up to 1" size
 POM seats & Buna O-rings standard on carbon steel valves
 Optional seal materials available for extreme temperature applications & fluid compatibility (Consult Factory)

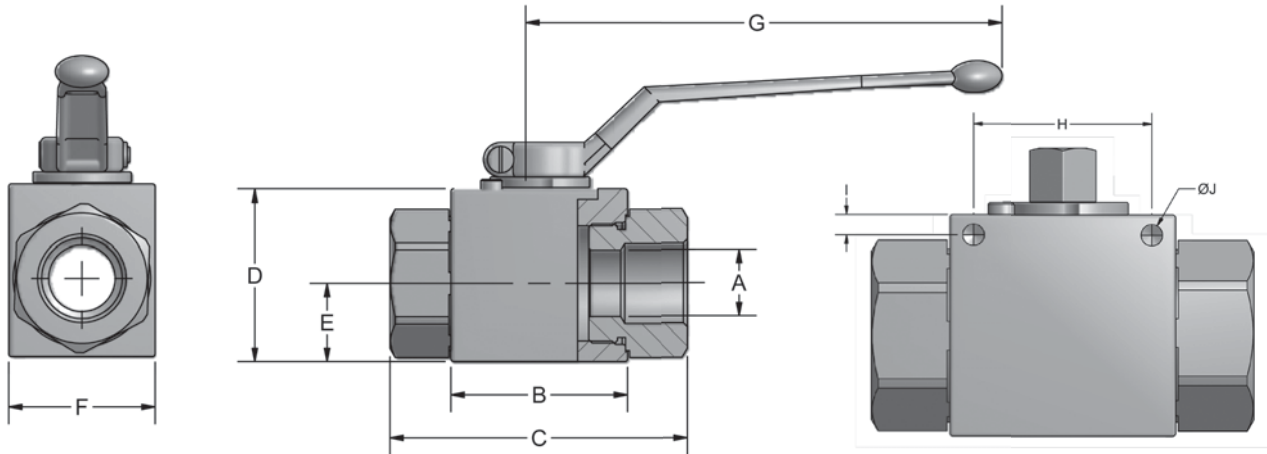

Optional Mounting Holes

Standard handles supplied are: 1/8" - 1/2" C1010ZB
 Refer to page 43 for details. 3/4" - 1 1/2" C1200ZB

AE2 SERIES FULL BORE															
SERIES		PSI MAX	A BORE	B	C	D		E	F		G	H	I	J	WEIGHT
NPT	SAE					CARBON	STAINLESS		CARBON	STAINLESS					
AE2 N1/8	N/A	7250	.16	1.67	2.80	1.38	C/F	.57	1.18	C/F	4.33	C/F	C/F	C/F	1.1 LBS
AE2 N1/4	AE2 S#4	7250	.24	1.67	2.80	1.38	1.38	.57	1.18	1.38	4.33	1.34	.18	.21	1.1 LBS
AE2 N3/8	AE2 S#6	7250	.39	1.75	2.87	1.57	1.57	.69	1.38	1.57	4.33	1.34	.18	.21	1.4 LBS
AE2 N1/2	AE2 S#8	7250	.51	1.90	3.27	1.69	1.77	.71	1.46	1.77	4.33	1.42	.20	.21	1.7 LBS
AE2 N3/4	AE2 S#12	5800	.79	2.46	3.74	2.17	2.17	.92	1.77	2.17	7.09	1.97	.24	.25	3.3 LBS
AE2 N1	AE2 S#16	5075	.98	2.62	4.41	2.56	2.56	1.16	2.17	2.56	7.09	1.97	.24	.25	5.0 LBS

AE2 SERIES REDUCED BORE															
SERIES		PSI MAX	A BORE	B	C	D		E	F		G	H	I	J	WEIGHT
NPT	SAE					CARBON	STAINLESS		CARBON	STAINLESS					
AE2 N1-1/4R	AE2 S#20R	5075	.98	2.62	4.72	2.56	2.56	1.16	2.17	2.56	7.09	C/F	C/F	C/F	5.2 LBS
AE2 N1-1/2R	AE2 S#24R	5075	.98	2.62	4.88	2.56	2.56	1.16	2.17	2.56	7.09	C/F	C/F	C/F	5.5 LBS

NPT threads in accordance with ANSI B.1.20.1 specifications.
 SAE threads in accordance with SAE J1926/1 specifications.

Model Code Breakdown

AE2 N1/2 _ - 1 1 D B _ _ _

Valve Series

Connection Type/Size

N	NPT Pipe Thread
S	SAE Straight Thread
B	BSP Thread

Bore Restriction

blank	Unrestricted Bore
R	Restricted Bore

Body & Adapter Material

1	Carbon Steel
2	316 Stainless Steel

Ball & Stem Material

1	Carbon Steel
2	316 Stainless Steel

Optional Mounting Holes

MH	Mounting Holes
----	----------------

Locking Kit or Optional Handle Code
(See pages 42 & 43)

Adapter & Stem Seals

B	Buna- Standard
V	Viton (Std on S/S)

Ball & Stem Seats

D	POM- Standard
P	PEEK
N	PA612

Please consult your system's seal manufacturer for recommendation of seal selection, as Anchor Fluid Power does not accept responsibility for seal selection.

MAXIMUM & MINIMUM WORKING TEMPERATURES FOR SEAL MATERIALS

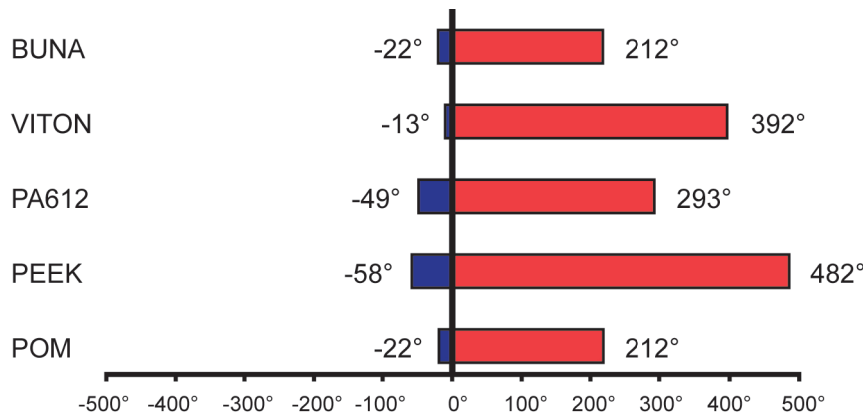

All temperatures are in degrees Fahrenheit.



FLOW, NEEDLE & CHECK VALVES

HYDRAULIC BALL VALVES

WELD COUPLINGS

FLANGES - CARBON STEEL

FLANGES - STAINLESS STEEL



Carbon Steel with Zinc Chromate Plating (RoHS Compliant)
 316 stainless steel available from stock
 Unrestricted bore available through 2" size
 POM seats & Buna O-rings standard on carbon steel valves
 Optional seal materials available for extreme temperature applications & fluid compatibility (Consult Factory)

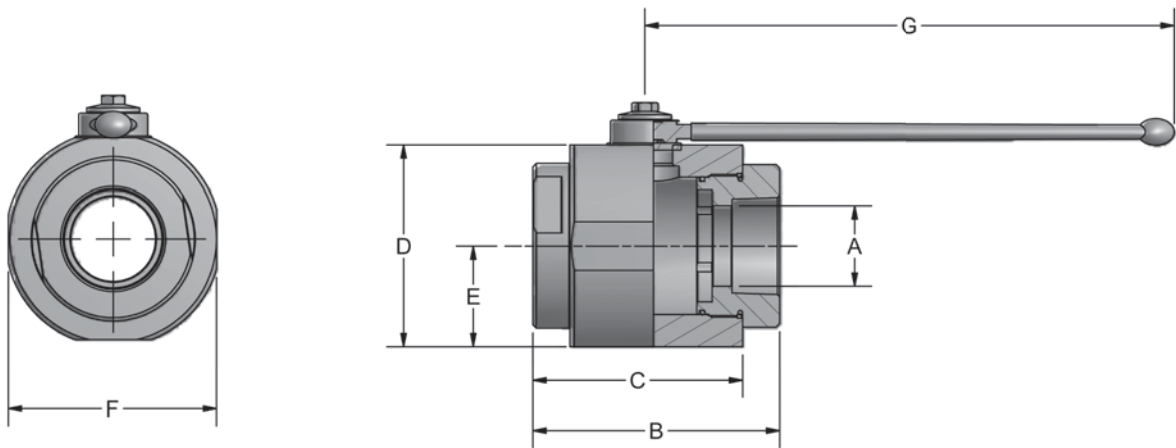

Standard handle supplied is C81302B. Refer to page 43 for details.

AB2 SERIES FULL BORE										
NPT	SAE	PSI MAX	A BORE	B	C	D	E	F	G	WEIGHT
AB2 N1-1/4	AB2 S#20	5075	1.26	4.53	3.74	3.66	1.83	3.46	11.81	15.4 LBS
AB2 N1-1/2	AB2 S#24	5075	1.57	5.16	4.25	4.21	2.11	4.02	11.81	16.3 LBS
AB2 N2	AB2 S#32	5075	1.97	5.51	4.53	4.49	2.24	4.65	11.81	19.9 LBS

NPT threads in accordance with ANSI B.1.20.1 specifications.
 SAE threads in accordance with SAE J1926/1 specifications.

Model Code Breakdown

AB2 N1/2 _ - 1 1 D B _

Valve Series

Connection Type/Size

N	NPT Pipe Thread
S	SAE Straight Thread
B	BSPB Thread

Bore Restriction

blank	Unrestricted Bore
R	Restricted Bore

Body & Adapter Material

1	Carbon Steel
2	316 Stainless Steel

Ball & Stem Material

1	Carbon Steel
2	316 Stainless Steel

Locking Kit or Optional Handle Code
(See pages 42 & 43)

Adapter & Stem Seals

B	Buna- Standard
V	Viton (Std on S/S)

Ball & Stem Seats

D	POM- Standard
P	PEEK
N	PA612

Please consult your system's seal manufacturer for recommendation of seal selection, as Anchor Fluid Power does not accept responsibility for seal selection.

MAXIMUM & MINIMUM WORKING TEMPERATURES FOR SEAL MATERIALS

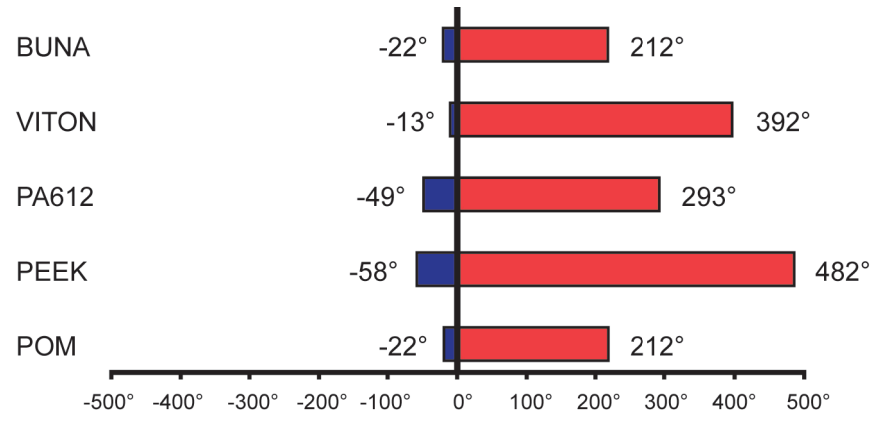

All temperatures are in degrees Fahrenheit.

FLOW, NEEDLE & CHECK VALVES

HYDRAULIC BALL VALVES

WELD COUPLINGS

FLANGES - CARBON STEEL

FLANGES - STAINLESS STEEL

FLOW, NEEDLE & CHECK VALVES

HYDRAULIC BALL VALVES

WELD COUPLINGS

FLANGES - CARBON STEEL

FLANGES - STAINLESS STEEL

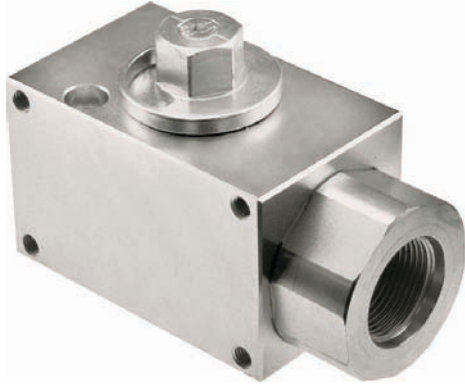

- Carbon Steel with Zinc Chromate Plating (RoHS Compliant)
- Hex stem eliminates need for attached handle
- Detented stop washer prevents accidental actuation
- Mounting holes standard
- Max pressure of 7250 PSI on all sizes
- No handle available for this series
- Optional weld mounting plates sold separately

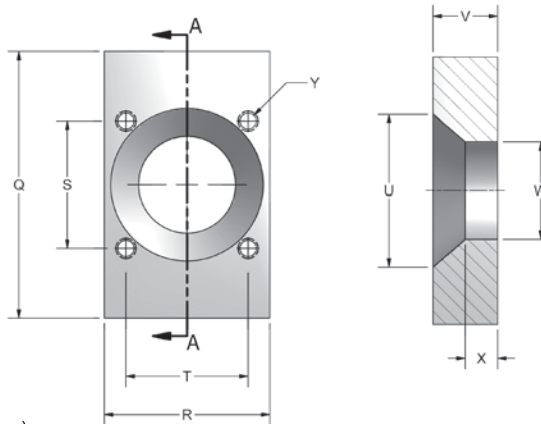
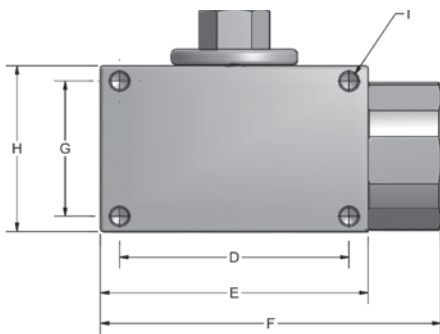
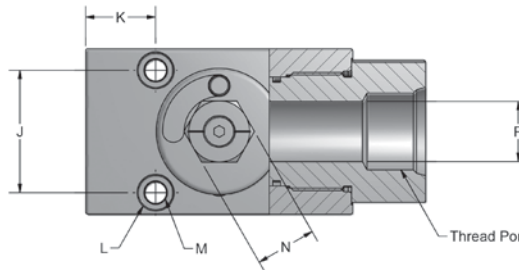
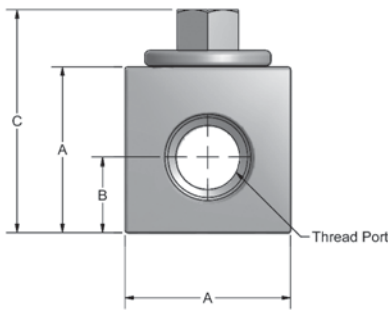

*Weld Plate Mounting Pattern Matches "J" Dimension (Top of Valve)

AV2 SERIES																	
NPT	SAE	A	B	C	D	E	F	G	H	I	J	K	L	M	N	P	WEIGHT
AV2N1/2	AV2S#8	1.77	0.79	2.74	2.52	3.15	4.07	1.30	2.46	M8 X 1.25	1.26	0.91	0.41	0.25	0.75	0.51	2.9 LBS
AV2N3/4	AV2S#12	2.17	0.92	2.89	3.15	3.98	5.10	1.69	3.05	M8 X 1.25	1.57	1.00	0.53	0.32	0.94	0.79	5.3 LBS
AV2N1	AV2S#16	2.56	1.16	3.29	3.54	4.13	5.26	2.09	3.44	M8 X 1.25	1.89	1.08	0.53	0.32	0.94	0.98	7.6 LBS
AV2N1-1/4R	AV2S#20R	2.56	1.16	3.29	3.54	4.13	5.26	2.09	3.44	M8 X 1.25	1.89	1.08	0.53	0.32	0.94	0.98	7.2 LBS
AV2N1-1/4	AV2S#20	3.15	1.32	3.88	3.39	4.13	5.26	2.52	4.07	M8 X 1.25	2.36	0.96	0.53	0.32	1.26	1.26	11.0 LBS

WELD MOUNTING PLATES											
PART #	VALVE SIZE	Q	R	S	T	U	V	W	X	Y	KIT INCLUDED SHCS
*WP-AV#8U	1/2"	3.15	1.77	1.33	1.26	N/A	1.00	N/A	N/A	M6 X 1.00	M6 X 50 MM
WP-AV#12U	3/4"	3.98	2.17	1.98	1.57	1.97	1.00	1.50	.50	5/16-18 UNC-2B	5/16 X 2.25"
WP-AV#16U	1" & 1 1/4" REDUCED	4.13	2.56	1.97	1.89	2.36	1.00	1.50	.50	5/16-18 UNC-2B	5/16 X 2.75"
WP-AV#20U	1 1/4" FULL	4.13	3.15	2.21	2.36	2.86	1.00	1.50	.50	5/16-18 UNC-2B	5/16 X 3.25"

*No internal weld hole on this size weld plate

Model Code Breakdown

AV2 N1/2 _ - 1 1 D V

Valve Series

Connection Type/Size

N	NPT Pipe Thread
S	SAE Straight Thread

Bore Restriction

blank	Unrestricted Bore
R	Restricted Bore

Body & Adapter Material

1	Carbon Steel
---	--------------

Adapter & Stem Seals

V	Viton (Standard)
---	------------------

Ball & Stem Seats

D	POM
---	-----

Ball & Stem Material

1	Carbon Steel
---	--------------

Please consult your system's seal manufacturer for recommendation of seal selection, as Anchor Fluid Power does not accept responsibility for seal selection.

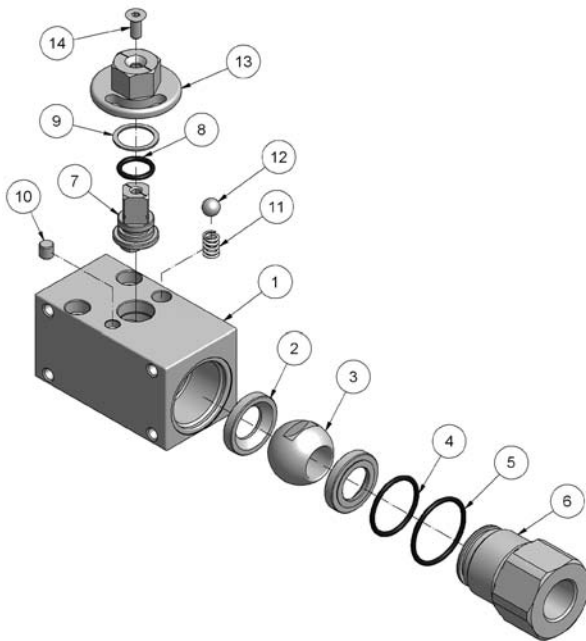

Parts List		
ITEM	QTY	PART NUMBER
1	1	AV2 Valve Body
2	2	Ball Seats
3	1	Ball
4	1	Adapter O-Ring (Small)
5	1	Adapter O-Ring (Large)
6	1	Adapter
7	1	Stem
8	1	Stem O-Ring
9	1	Stem Seat
10	1	Stop Pin
11	1	Spring
12	1	Detent Ball
13	1	Alignment Stop
14	1	Screw



FLOW, NEEDLE & CHECK VALVES

HYDRAULIC BALL VALVES

WELD COUPLINGS

FLANGES - CARBON STEEL

FLANGES - STAINLESS STEEL

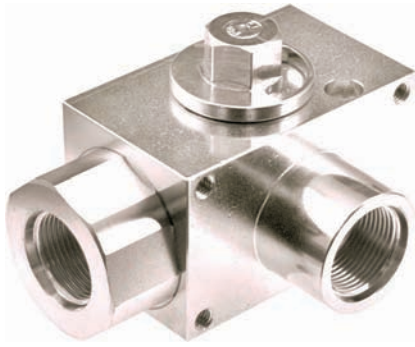

Carbon Steel with Zinc Chromate Plating (RoHS Compliant)
 Hex stem eliminates need for attached handle
 No handle available for this series
 Detented stop washer prevents accidental actuation
 Mounting holes standard
 Max pressure of 5075 PSI on all sizes
 Optional weld mounting plates sold separately

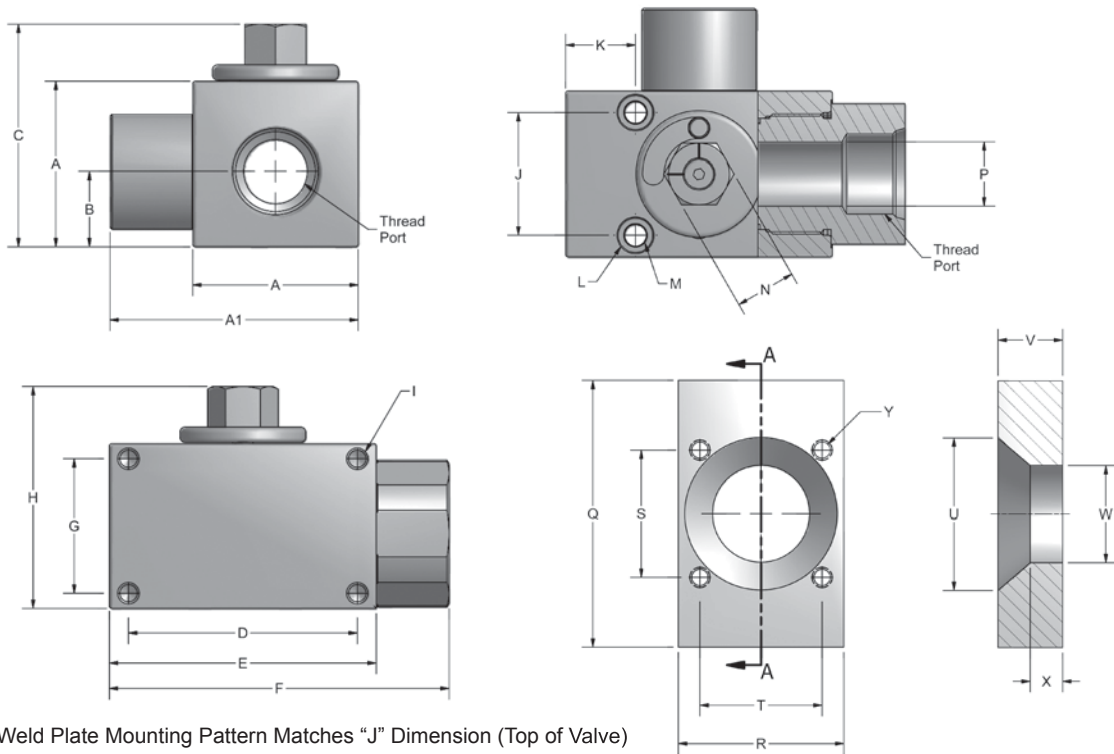

AV3 SERIES																		
NPT	SAE	A	A1	B	C	D	E	F	G	H	I	J	K	L	M	N	P	WEIGHT
AV3LN1/2	AV3LS#8	1.77	2.62	0.79	2.74	2.52	3.15	4.07	1.30	2.46	M8 X 1.25	1.26	0.91	0.41	0.25	0.75	0.51	3.0 LBS
AV3LN3/4	AV3LS#12	2.17	3.35	0.92	2.89	3.15	3.98	5.10	1.69	3.05	M8 X 1.25	1.57	1.00	0.53	0.32	0.94	0.79	5.5 LBS
AV3LN1	AV3LS#16	2.56	3.84	1.16	3.29	3.54	4.13	5.26	2.09	3.44	M8 X 1.25	1.89	1.08	0.53	0.32	0.94	0.98	7.9 LBS
AV3LN1-1/4R	AV3LS#20R	2.56	3.90	1.16	3.29	3.54	4.13	5.26	2.09	3.44	M8 X 1.25	1.89	1.08	0.53	0.32	0.94	0.98	7.7 LBS
AV3LN1-1/4	AV3LS#20	3.15	4.65	1.32	3.88	3.39	4.13	5.26	2.52	4.07	M8 X 1.25	2.36	0.96	0.53	0.32	1.26	1.26	11.7 LBS

WELD MOUNTING PLATES												
PART #	VALVE SIZE	Q	R	S	T	U	V	W	X	Y	KIT INCLUDED SHCS	
*WP-AV#8U	1/2"	3.15	1.77	1.33	1.26	N/A	1.00	N/A	N/A	M6 X 1.00	M6 X 50 MM	
WP-AV#12U	3/4"	3.98	2.17	1.98	1.57	1.97	1.00	1.50	.50	5/16-18 UNC-2B	5/16 X 2.25"	
WP-AV#16U	1" & 1 1/4" REDUCED	4.13	2.56	1.97	1.89	2.36	1.00	1.50	.50	5/16-18 UNC-2B	5/16 X 2.75"	
WP-AV#20U	1 1/4" FULL	4.13	3.15	2.21	2.36	2.86	1.00	1.50	.50	5/16-18 UNC-2B	5/16 X 3.25"	

Model Code Breakdown

AV3L N1/2 _ - 1 1 D V

Valve Series

Connection Type/Size

N	NPT Pipe Thread
S	SAE Straight Thread

Bore Restriction

blank	Unrestricted Bore
R	Restricted Bore

Body & Adapter Material

1	Carbon Steel
---	--------------

Adapter & Stem Seals

V	Viton (Standard)
---	------------------

Ball & Stem Seats

D	POM
---	-----

Ball & Stem Material

1	Carbon Steel
---	--------------

FLOW, NEEDLE & CHECK VALVES

HYDRAULIC BALL VALVES

WELD COUPLINGS

FLANGES - CARBON STEEL

FLANGES - STAINLESS STEEL

Please consult your system's seal manufacturer for recommendation of seal selection, as Anchor Fluid Power does not accept responsibility for seal selection.

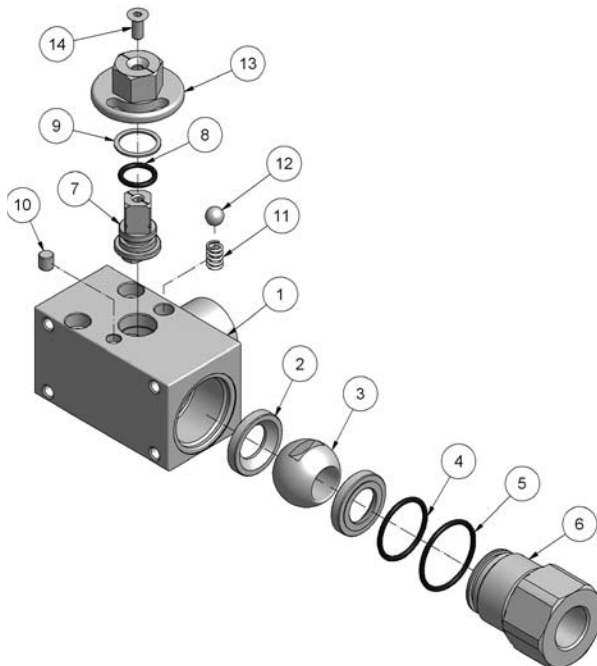

Parts List		
ITEM	QTY	PART NUMBER
1	1	AV3 Valve Body
2	2	Ball Seats
3	1	Ball
4	1	Adapter O-Ring (Small)
5	1	Adapter O-Ring (Large)
6	1	Adapter
7	1	Stem
8	1	Stem O-Ring
9	1	Stem Seat
10	1	Stop Pin
11	1	Spring
12	1	Detent Ball
13	1	Alignment Stop
14	1	Screw



FLOW, NEEDLE & CHECK VALVES

HYDRAULIC BALL VALVES

WELD COUPLINGS

FLANGES - CARBON STEEL

FLANGES - STAINLESS STEEL

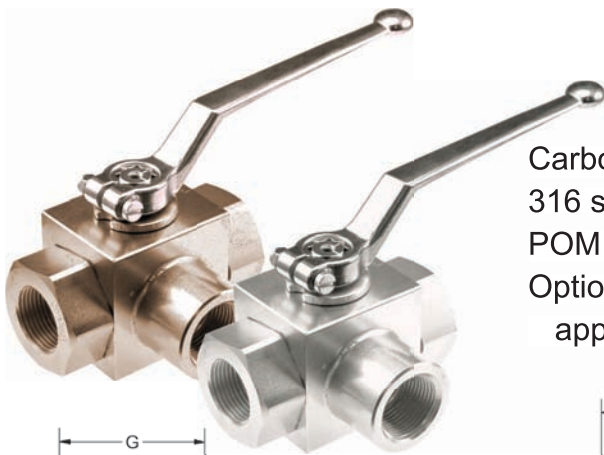

Carbon Steel with Zinc Chromate Plating (RoHS Compliant)
 316 stainless steel available from stock
 POM seats & Buna O-rings standard on carbon steel valves
 Optional seal materials available for extreme temperature applications & fluid compatibility (Consult Factory)

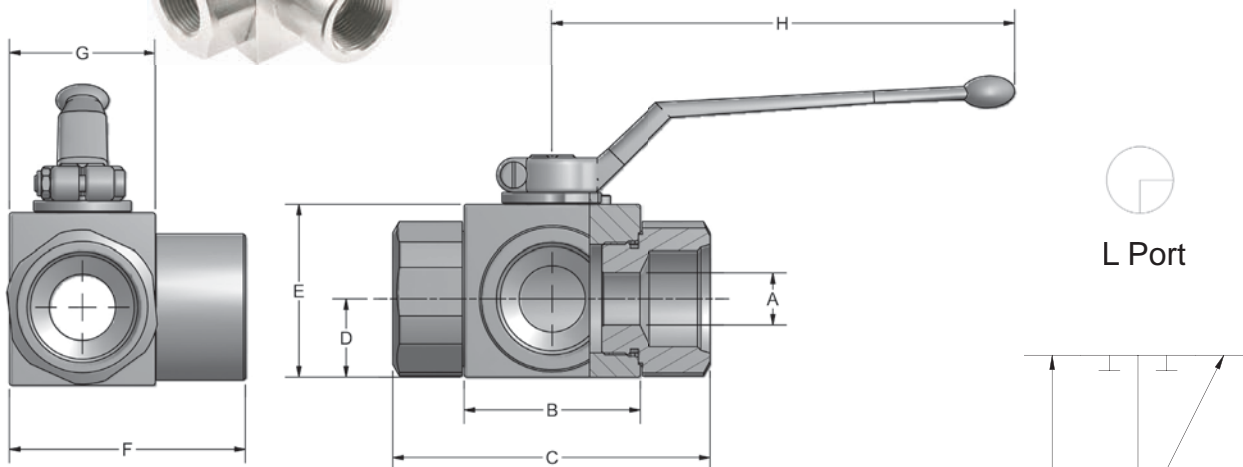

Standard handles supplied are: 1/8" - 1/2" C1010ZB
 Refer to page 43 for details. 3/4" - 1 1/2" C1200ZB

L Port

L Port

AE3 SERIES FULL BORE											
NPT	SAE	PSI MAX	A BORE	B	C	D	E	F	G	H	WEIGHT
AE3 L N1/8	N/A	5800	.16	1.70	2.80	.57	1.38	1.91	1.18	4.33	1.2 LBS
AE3 L N1/4	AE3 L S#4	5800	.24	1.70	2.80	.57	1.38	1.91	1.18	4.33	1.2 LBS
AE3 L N3/8	AE3 L S#6	5800	.39	1.75	2.87	.67	1.57	2.15	1.38	4.33	1.5 LBS
AE3 L N1/2	AE3 L S#8	5075	.51	1.91	3.27	.71	1.69	2.30	1.46	4.33	1.8 LBS
AE3 L N3/4	AE3 L S#12	5075	.79	2.46	3.74	.92	2.17	2.95	1.77	7.09	3.5 LBS
AE3 L N1	AE3 L S#16	5075	.98	2.62	4.41	1.16	2.56	3.44	2.17	7.09	5.3 LBS

AE3 SERIES REDUCED BORE											
NPT	SAE	PSI MAX	A BORE	B	C	D	E	F	G	H	WEIGHT
AE3 L N1-1/4R	AE3 L S#20R	5075	.98	2.62	4.72	1.16	2.56	3.44	2.17	7.09	5.7 LBS
AE3 L N1-1/2R	AE3 L S#24R	5075	.98	2.62	4.88	1.16	2.56	3.44	2.17	7.09	6.1 LBS

Only pressurize center port. Side ports should not be pressurized or be exposed to back pressure that is greater than the inlet pressure. Failure to follow these guidelines will result in internal leakage through the valve. For applications requiring pressure applied to side ports, please refer to AE3K Series valves on page 26.

NPT threads in accordance with ANSI B.1.20.1 specifications.
 SAE threads in accordance with SAE J1926/1 specifications.

Model Code Breakdown

AE3L N1/2 _ - 1 1 D B _

Valve Series

Port Type

L	"Diverter" L-Port
---	-------------------

Connection Type/Size

N	NPT Pipe Thread
S	SAE Straight Thread

Bore Restriction

blank	Unrestricted Bore
R	Restricted Bore

Body & Adapter Material

1	Carbon Steel
2	316 Stainless Steel

Ball & Stem Material

1	Carbon Steel
2	316 Stainless Steel

Locking Kit or Optional Handle Code
(See pages 42 & 43)

Adapter & Stem Seals

B	Buna- Standard
V	Viton (Std on S/S)

Ball & Stem Seats

D	POM- Standard
P	PEEK
N	PA612

Please consult your system's seal manufacturer for recommendation of seal selection, as Anchor Fluid Power does not accept responsibility for seal selection.

MAXIMUM & MINIMUM WORKING TEMPERATURES FOR SEAL MATERIALS

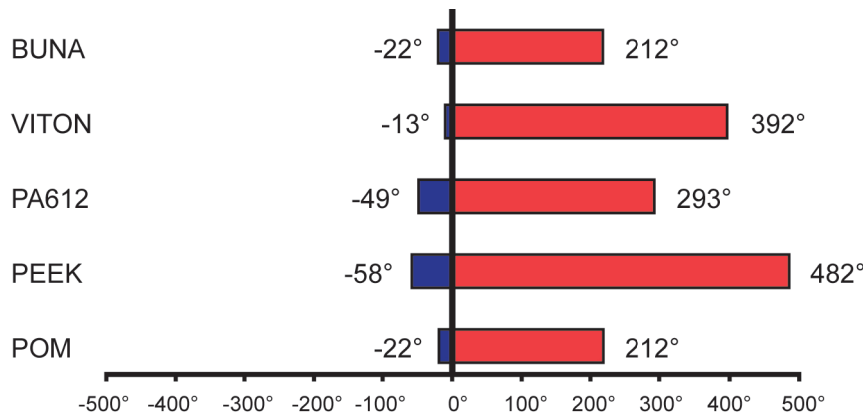

All temperatures are in degrees Fahrenheit.

FLOW, NEEDLE & CHECK VALVES

HYDRAULIC BALL VALVES

WELD COUPLINGS

FLANGES - CARBON STEEL

FLANGES - STAINLESS STEEL



FLOW, NEEDLE & CHECK VALVES

HYDRAULIC BALL VALVES

WELD COUPLINGS

FLANGES - CARBON STEEL

FLANGES - STAINLESS STEEL

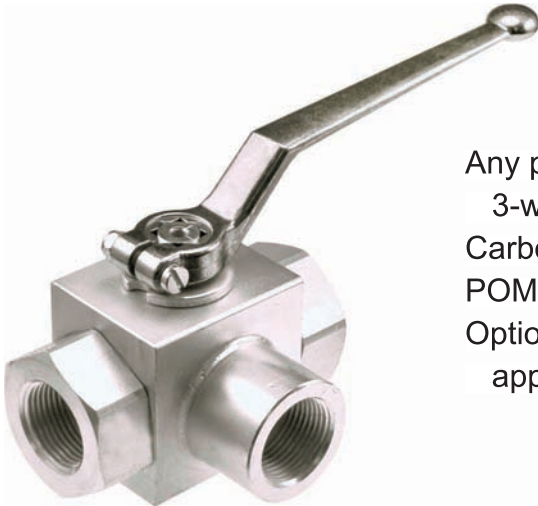

Any port may be pressurized on this series valve ("True" 3-way valve)
 Carbon Steel with Zinc Chromate Plating (RoHS Compliant)
 POM seats & Buna O-rings standard on carbon steel valves
 Optional seal materials available for extreme temperature applications & fluid compatibility (Consult Factory)

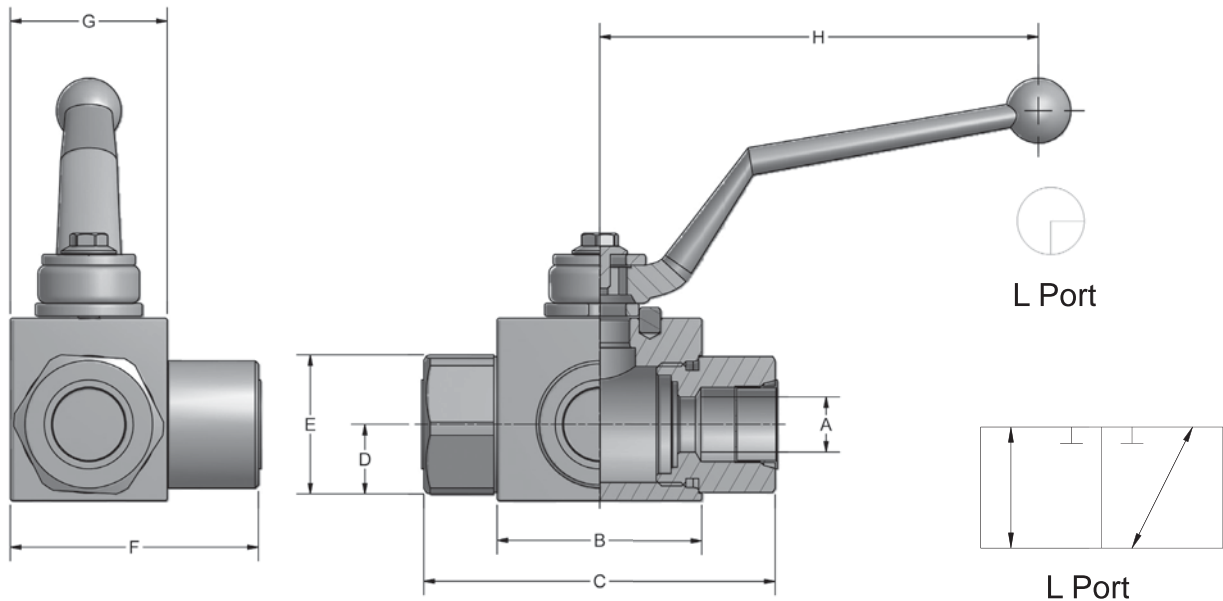

Standard handles supplied are: 1/4" - 1/2" C1010ZB
 Refer to page 43 for details. 3/4" - 1" C1200ZB

AE3K SERIES FULL BORE											
NPT	SAE	PSI MAX	A	B	C	D	E	F	G	H	WEIGHT
AE3K L N1/4	AE3K L S#4	5800	.24	1.67	2.80	.57	1.38	1.91	1.18	4.33	1.2 LBS
AE3K L N3/8	AE3K L S#6	5800	.39	1.75	2.87	.69	1.57	2.15	1.38	4.33	1.5 LBS
AE3K L N1/2	AE3K L S#8	5075	.51	1.91	3.27	.71	1.69	2.30	1.46	4.33	1.8 LBS
AE3K L N3/4	AE3K L S#12	5075	.79	2.46	3.74	.92	2.17	2.95	1.77	7.01	3.5 LBS
AE3K L N1	AE3K L S#16	5075	.98	2.62	4.41	1.16	2.56	3.44	2.17	7.01	5.3 LBS

NPT threads in accordance with ANSI B.1.20.1 specifications.
 SAE threads in accordance with SAE J1926/1 specifications.

Model Code Breakdown

AE3KL N1/2 _ - 1 1 D B _

Valve Series

Port Type

L	"Diverter" L-Port
---	-------------------

Connection Type/Size

N	NPT Pipe Thread
S	SAE Straight Thread

Bore Restriction

blank	Unrestricted Bore
R	Restricted Bore

Body & Adapter Material

1	Carbon Steel
---	--------------

Ball & Stem Material

1	Carbon Steel
---	--------------

Locking Kit or Optional Handle Code
(See pages 42 & 43)

Adapter & Stem Seals

B	Buna- Standard
V	Viton

Ball & Stem Seats

D	POM- Standard
P	PEEK
N	PA612

FLOW, NEEDLE & CHECK VALVES

HYDRAULIC BALL VALVES

WELD COUPLINGS

FLANGES - CARBON STEEL

FLANGES - STAINLESS STEEL

Please consult your system's seal manufacturer for recommendation of seal selection, as Anchor Fluid Power does not accept responsibility for seal selection.

MAXIMUM & MINIMUM WORKING TEMPERATURES FOR SEAL MATERIALS

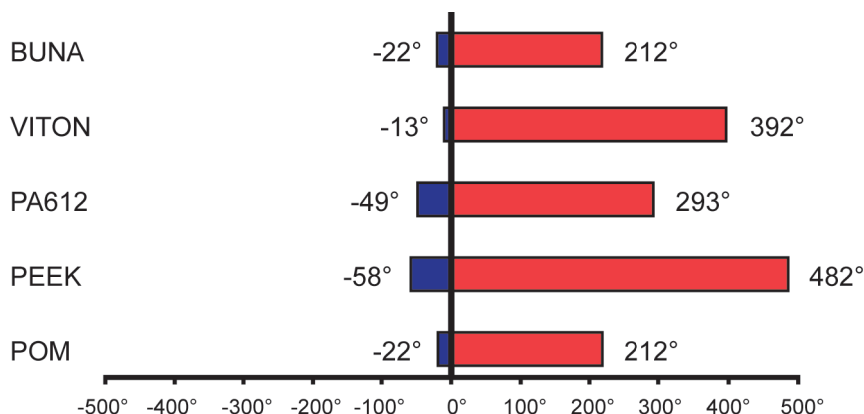

All temperatures are in degrees Fahrenheit.



Carbon Steel with Zinc Chromate Plating (RoHS Compliant)
 POM seats & Buna O-rings standard on carbon steel valves
 Optional seal materials available for extreme temperature applications & fluid compatibility (Consult Factory)



L Port

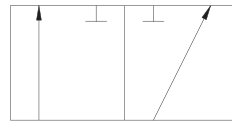

L Port

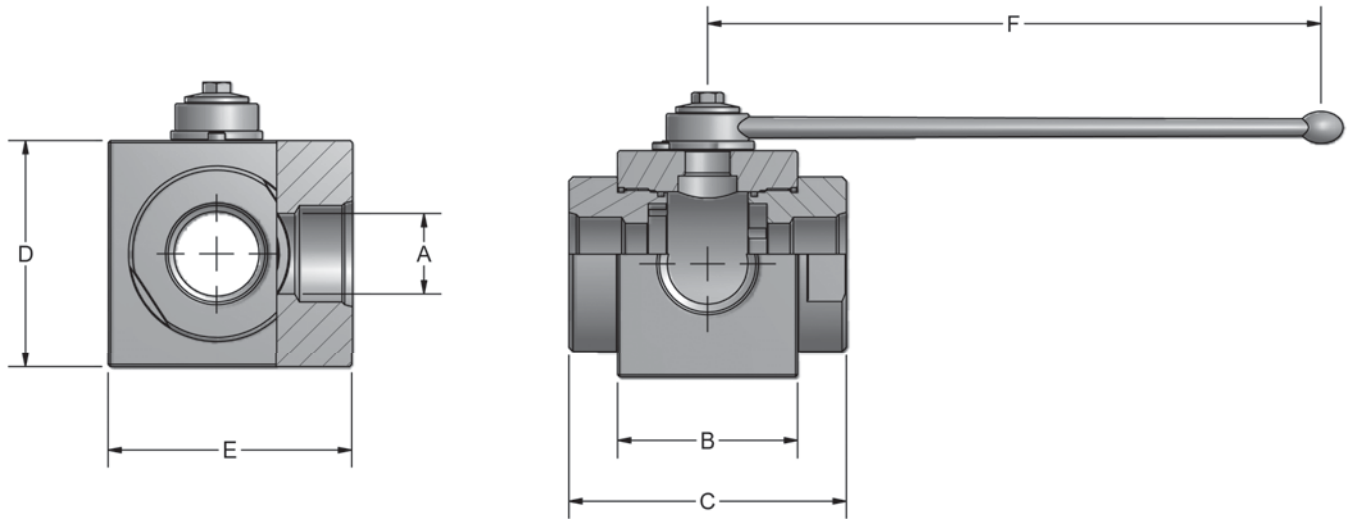

Standard handle supplied is C81302B. Refer to page 43 for details.

AB3 SERIES FULL BORE								
NPT	PSI MAX	A BORE	B	C	D	E	F	WEIGHT
AB3 L N1-1/4	5075	1.26	2.95	4.53	3.66	3.90	11.81	12.6 LBS
AB3 L N1-1/2	5075	1.57	3.35	5.16	4.21	4.53	11.81	19.0 LBS
AB3 L N2	5075	1.97	3.86	5.51	4.49	5.04	11.81	23.4 LBS

Only pressurize center port. Side ports should not be pressurized or be exposed to back-pressure that is greater than the inlet pressure. Failure to follow these guidelines will result in internal leakage through the valve.

NPT threads in accordance with ANSI B.1.20.1 specifications.

Model Code Breakdown

AB3L N1 1/2 - 1 1 D B _

Valve Series •

Port Type •

L	"Diverter" L-Port
---	-------------------

Connection Type/Size •

N	NPT Pipe Thread
---	-----------------

Body & Adapter Material •

1	Carbon Steel
---	--------------

Ball & Stem Material •

1	Carbon Steel
---	--------------

• **Locking Kit or Optional Handle Code**
(See pages 42 & 43)

• **Adapter & Stem Seals**

B	Buna- Standard
V	Viton

• **Ball & Stem Seats**

D	POM- Standard
P	PEEK
N	PA612

Please consult your system's seal manufacturer for recommendation of seal selection, as Anchor Fluid Power does not accept responsibility for seal selection.

MAXIMUM & MINIMUM WORKING TEMPERATURES FOR SEAL MATERIALS

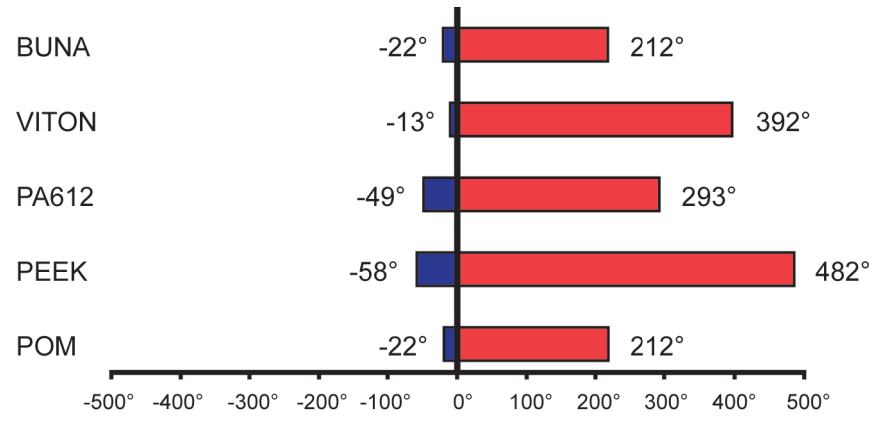

All temperatures are in degrees Fahrenheit.

FLOW, NEEDLE & CHECK VALVES

HYDRAULIC BALL VALVES

WELD COUPLINGS

FLANGES - CARBON STEEL

FLANGES - STAINLESS STEEL

FLOW, NEEDLE & CHECK VALVES

HYDRAULIC BALL VALVES

WELD COUPLINGS

FLANGES - CARBON STEEL

FLANGES - STAINLESS STEEL

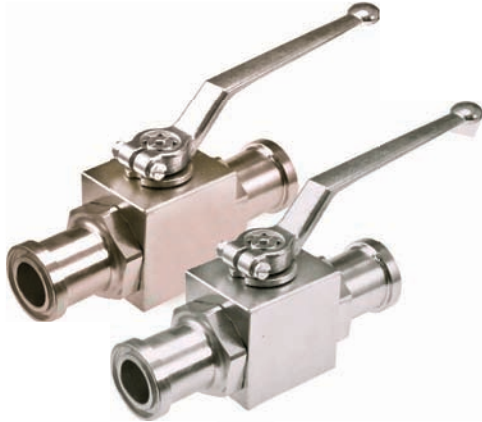

Carbon Steel with Zinc Chromate Plating (RoHS Compliant)
 316 stainless steel available from stock
 POM seats & Buna O-rings standard on carbon steel valves
 Optional seal materials available for extreme temperature applications & fluid compatibility (Consult Factory)

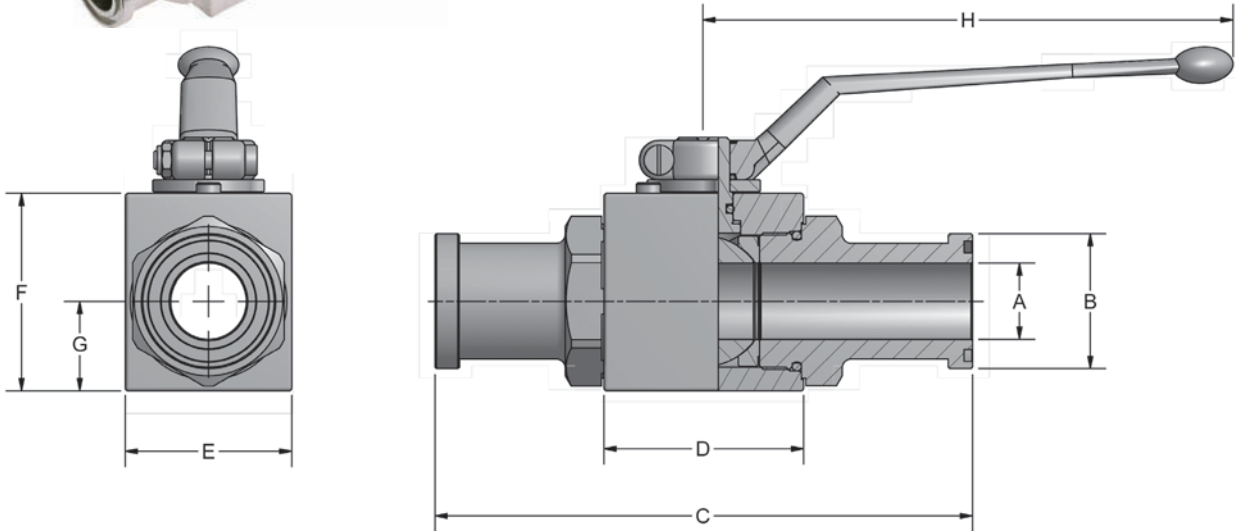

Standard handles supplied are:
 Refer to page 43 for details.

#8
 #12 & #16

C1010ZB
 C1200ZB

AES SERIES - CODE 61										
SERIES	PSI MAX	A BORE	B	C	D	E	F	G	H	WEIGHT
AES3#8	5000	.51	1.19	5.96	1.91	1.46	1.70	.71	4.33	2.1 LBS
AES3#12	5000	.79	1.50	6.38	2.46	1.77	2.17	.92	7.09	3.8 LBS
AES3#16	5000	.98	1.75	7.00	2.62	2.17	2.56	1.16	7.09	5.7 LBS

AES SERIES - CODE 62										
SERIES	PSI MAX	A BORE	B	C	D	E	F	G	H	WEIGHT
AES6#8	6000	.51	1.24	5.96	1.91	1.46	1.70	.71	4.33	2.1 LBS
AES6#12	6000	.79	1.63	6.85	2.46	1.77	2.17	.92	7.09	4.0 LBS
AES6#16	5000	.98	1.88	7.80	2.62	2.17	2.56	1.16	7.09	6.1 LBS

Model Code Breakdown

AES3 #16 - 1 1 D B

Valve Series

AES3	Code 61
AES6	Code 62

Connection Size

Body & Adapter Material

1	Carbon Steel
2	316 Stainless Steel

Ball & Stem Material

1	Carbon Steel
2	316 Stainless Steel

Locking Kit or Optional Handle Code

(See pages 42 & 43)

Adapter & Stem Seals

B	Buna- Standard
V	Viton (Std on S/S)

Ball & Stem Seats

D	POM- Standard
P	PEEK
N	PA612

Please consult your system's seal manufacturer for recommendation of seal selection, as Anchor Fluid Power does not accept responsibility for seal selection.

MAXIMUM & MINIMUM WORKING TEMPERATURES FOR SEAL MATERIALS

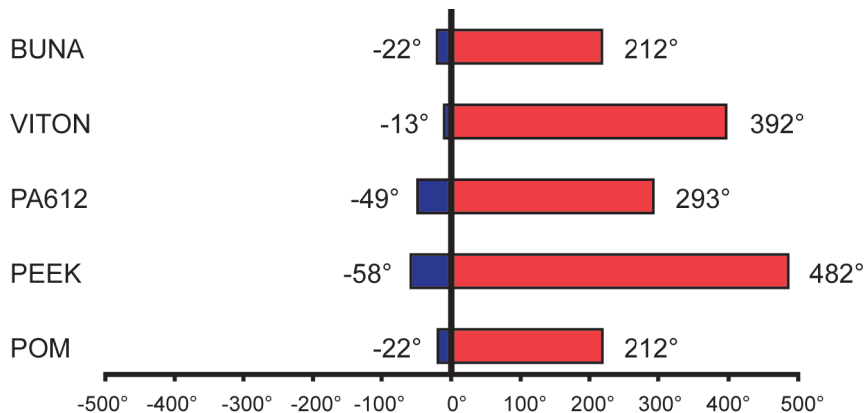

All temperatures are in degrees Fahrenheit.

FLOW, NEEDLE & CHECK VALVES

HYDRAULIC BALL VALVES

WELD COUPLINGS

FLANGES - CARBON STEEL

FLANGES - STAINLESS STEEL



Carbon Steel with Zinc Chromate Plating (RoHS Compliant)
 316 stainless steel available from stock
 POM seats & Buna O-rings standard on carbon steel valves
 Optional seal materials available for extreme temperature applications & fluid compatibility (Consult Factory)

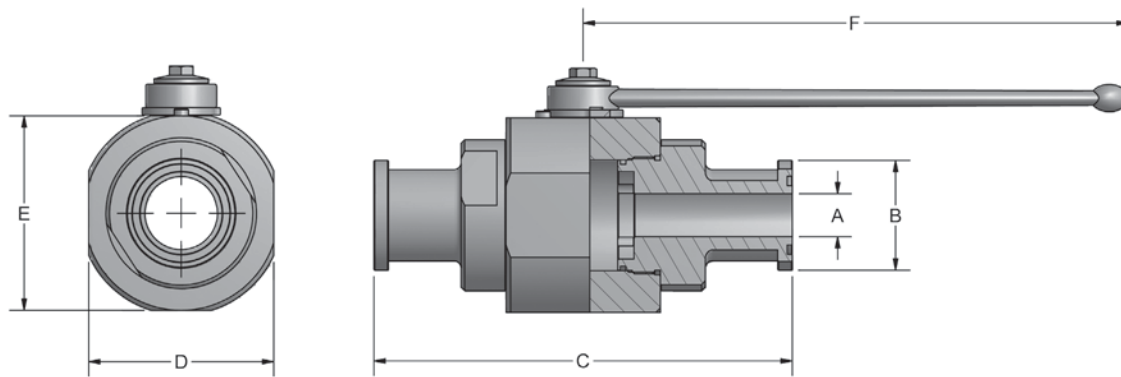

Standard handle supplied is C92501Z-SW17. Refer to page 43 for details.

ABS SERIES - CODE 61								
SERIES	PSI MAX	A BORE	B	C	D	E	F	WEIGHT
ABS3#20	4000	1.26	2.00	7.50	3.46	3.66	11.81	12.0 LBS
ABS3#24	3000	1.57	2.37	9.08	4.02	4.21	11.81	18.2 LBS
ABS3#32	3000	1.89	2.81	9.13	4.65	4.49	11.81	21.7 LBS

ABS SERIES - CODE 62								
SERIES	PSI MAX	A BORE	B	C	D	E	F	WEIGHT
ABS6#20	5000	1.26	2.13	8.78	3.46	3.66	11.81	12.8 LBS
ABS6#24	5000	1.57	2.50	11.06	4.02	4.21	11.81	18.2 LBS
ABS6#32	5000	1.89	3.13	12.44	4.65	4.49	11.81	26.0 LBS

Model Code Breakdown

ABS3 #32 - 1 1 D B _

Valve Series

ABS3	Code 61
ABS6	Code 62

Connection Size

Body & Adapter Material

1	Carbon Steel
2	316 Stainless Steel

Ball & Stem Material

1	Carbon Steel
2	316 Stainless Steel

Locking Kit or Optional Handle Code
(See pages 42 & 43)

Adapter & Stem Seals

B	Buna- Standard
V	Viton (Std on S/S)

Ball & Stem Seats

D	POM- Standard
P	PEEK
N	PA612

Please consult your system's seal manufacturer for recommendation of seal selection, as Anchor Fluid Power does not accept responsibility for seal selection.

MAXIMUM & MINIMUM WORKING TEMPERATURES FOR SEAL MATERIALS

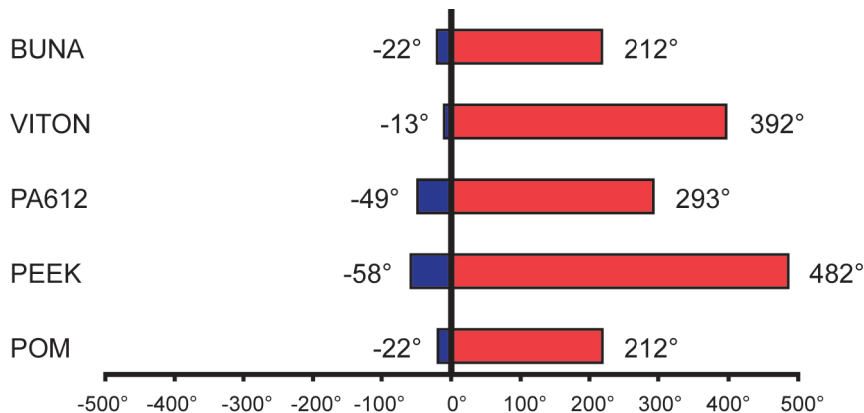

All temperatures are in degrees Fahrenheit.

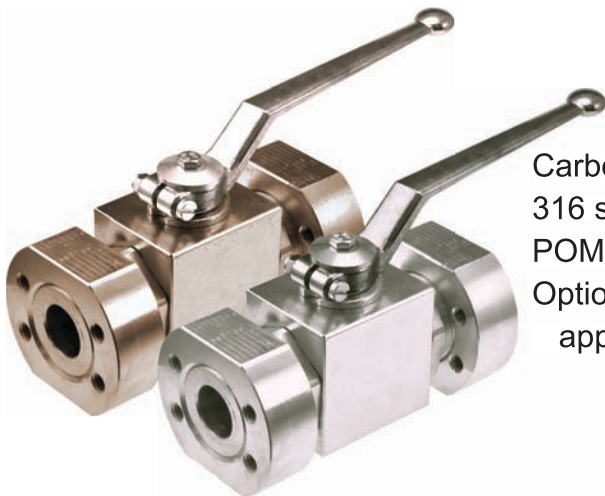

Carbon Steel with Zinc Chromate Plating (RoHS Compliant)
 316 stainless steel available from stock
 POM seats & Buna O-rings standard on carbon steel valves
 Optional seal materials available for extreme temperature applications & fluid compatibility (Consult Factory)

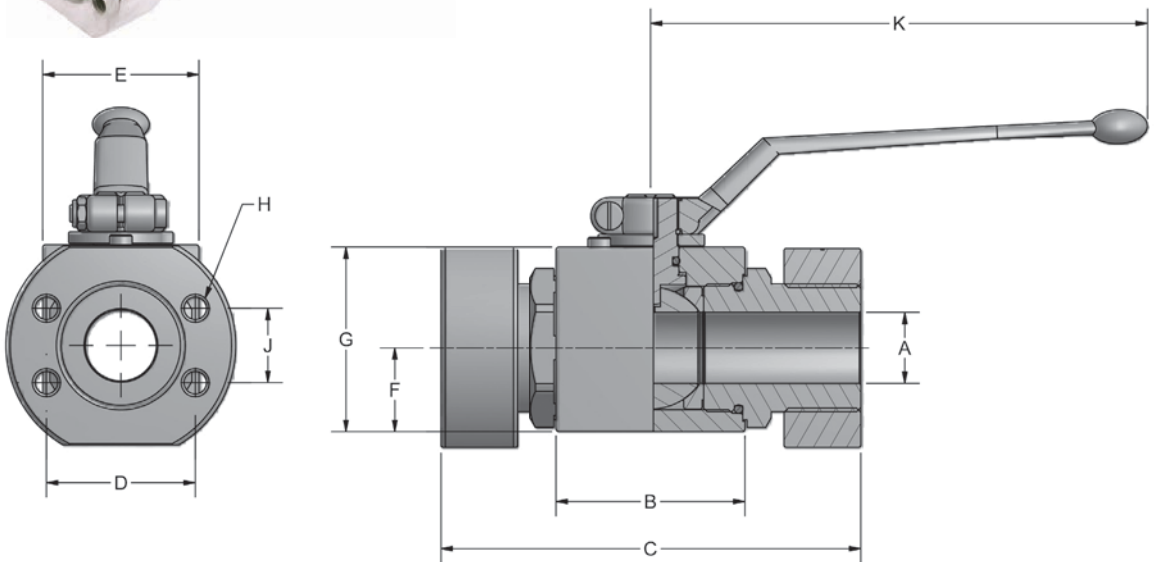

Standard handles supplied are: #8 C1010ZB
 Refer to page 43 for details. #12 - #16 C1200ZB

AEF SERIES - CODE 61												
SERIES	PSI MAX	A BORE	B	C	D	E	F	G	H UNC-2B	J	K	WEIGHT
AEF3#8	5000	.51	1.91	4.72	1.50	1.46	.71	1.69	5/16-18	.69	4.33	3.3 LBS
AEF3#12	5000	.79	2.46	5.35	1.87	1.77	.92	2.17	3/8-16	.87	7.09	5.7 LBS
AEF3#16	5000	.98	2.62	5.83	2.06	2.17	1.16	2.56	3/8-16	1.03	7.09	8.6 LBS

AEF SERIES - CODE 62												
SERIES	PSI MAX	A BORE	B	C	D	E	F	G	H UNC-2B	J	K	WEIGHT
AEF6#8	6000	.51	1.91	4.72	1.59	1.46	.71	1.69	5/16-18	.72	4.33	3.3 LBS
AEF6#12	6000	.79	2.46	5.35	2.00	1.77	.92	2.17	3/8-16	.94	7.09	5.7 LBS
AEF6#16	5000	.98	2.62	5.83	2.25	2.17	1.16	2.56	7/16-14	1.09	7.09	8.6 LBS

Model Code Breakdown

AEF3 #16 - 1 1 D B

Valve Series

AEF3	Code 61
AEF6	Code 62

Connection Size

Body & Adapter Material

1	Carbon Steel
2	316 Stainless Steel

Ball & Stem Material

1	Carbon Steel
2	316 Stainless Steel

Locking Kit or Optional Handle Code
(See pages 42 & 43)

Adapter & Stem Seals

B	Buna- Standard
V	Viton (Std on S/S)

Ball & Stem Seats

D	POM- Standard
P	PEEK
N	PA612

Please consult your system's seal manufacturer for recommendation of seal selection, as Anchor Fluid Power does not accept responsibility for seal selection.

MAXIMUM & MINIMUM WORKING TEMPERATURES FOR SEAL MATERIALS

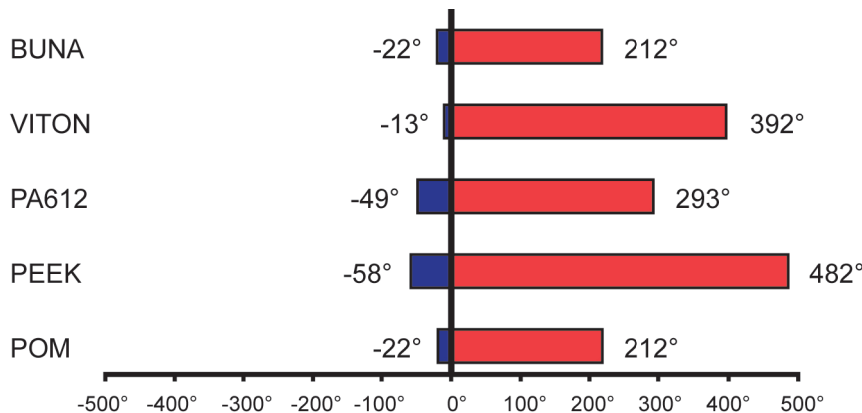

All temperatures are in degrees Fahrenheit.



FLOW, NEEDLE & CHECK VALVES

HYDRAULIC BALL VALVES

WELD COUPLINGS

FLANGES - CARBON STEEL

FLANGES - STAINLESS STEEL



Carbon Steel with Zinc Chromate Plating (RoHS Compliant)
 316 stainless steel available from stock
 POM seats & Buna O-rings standard on carbon steel valves
 Optional seal materials available for extreme temperature applications & fluid compatibility (Consult Factory)

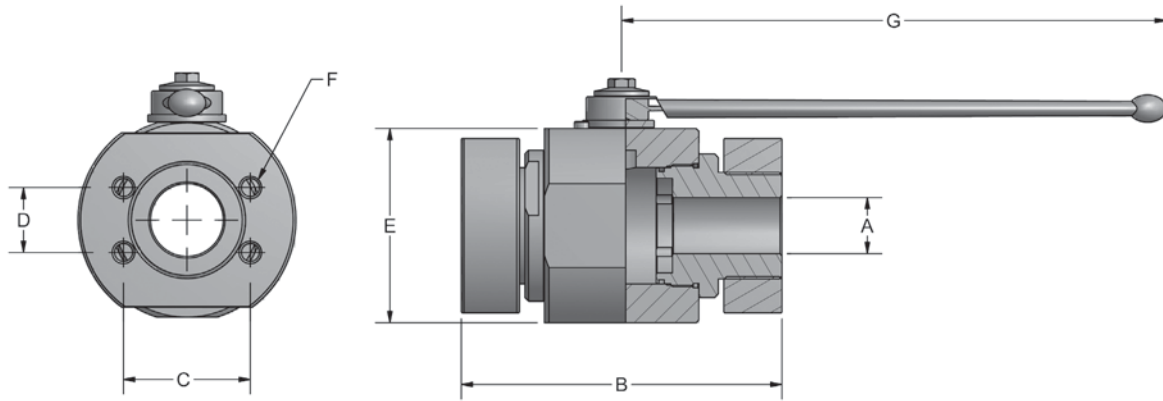

Standard handle supplied is C92501Z-SW17. Refer to page 43 for details.

ABF SERIES - CODE 61									
SERIES	PSI MAX	A BORE	B	C	D	E	F UNC-2B	G	WEIGHT
ABF3#20	4000	1.26	6.77	2.31	1.19	3.66	7/16-14	11.81	17.9 LBS
ABF3#24	3000	1.57	6.95	2.75	1.41	4.21	1/2-13	11.81	24.6 LBS
ABF3#32	3000	1.89	7.72	3.06	1.69	4.49	1/2-13	11.81	33.8 LBS

ABF SERIES - CODE 62									
SERIES	PSI MAX	A BORE	B	C	D	E	F UNC-2B	G	WEIGHT
ABF6#20	5000	1.26	6.77	2.63	1.25	3.66	1/2-13	11.81	17.9 LBS
ABF6#24	5000	1.57	6.95	3.13	1.44	4.21	5/8-11	11.81	24.6 LBS
ABF6#32	5000	1.89	7.72	3.81	1.75	4.49	3/4-10	11.81	33.8 LBS

Model Code Breakdown

ABF3 #32 - 1 1 D B _

Valve Series

ABF3	Code 61
ABF6	Code 62

Connection Size

Body & Adapter Material

1	Carbon Steel
2	316 Stainless Steel

Ball & Stem Material

1	Carbon Steel
2	316 Stainless Steel

Locking Kit or Optional Handle Code
(See pages 42 & 43)

Adapter & Stem Seals

B	Buna- Standard
V	Viton (Std on S/S)

Ball & Stem Seats

D	POM- Standard
P	PEEK
N	PA612

Please consult your system's seal manufacturer for recommendation of seal selection, as Anchor Fluid Power does not accept responsibility for seal selection.

MAXIMUM & MINIMUM WORKING TEMPERATURES FOR SEAL MATERIALS

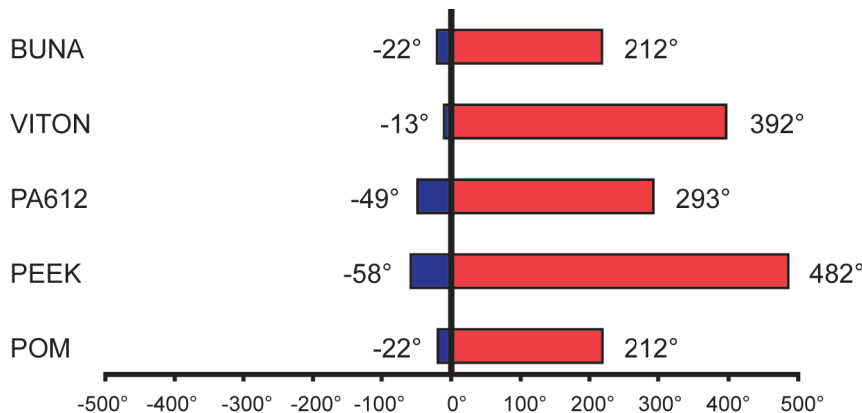

All temperatures are in degrees Fahrenheit.

FLOW, NEEDLE & CHECK VALVES

HYDRAULIC BALL VALVES

WELD COUPLINGS

FLANGES - CARBON STEEL

FLANGES - STAINLESS STEEL



FLOW, NEEDLE & CHECK VALVES

HYDRAULIC BALL VALVES

WELD COUPLINGS

FLANGES - CARBON STEEL

FLANGES - STAINLESS STEEL

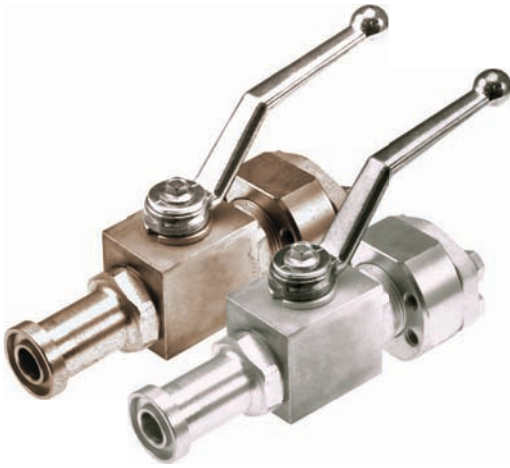

Flange Head X Flat-Face connections for insertion in between existing flange joints
 Ideal for flange mounting anywhere a flange connection exists or where hoses are already connected
 Carbon Steel with Zinc Chromate Plating (RoHS Compliant)
 316 stainless steel available
 POM seats & Buna O-rings standard on carbon steel valves
 Optional seal materials available for extreme temperature applications & fluid compatibility (Consult Factory)

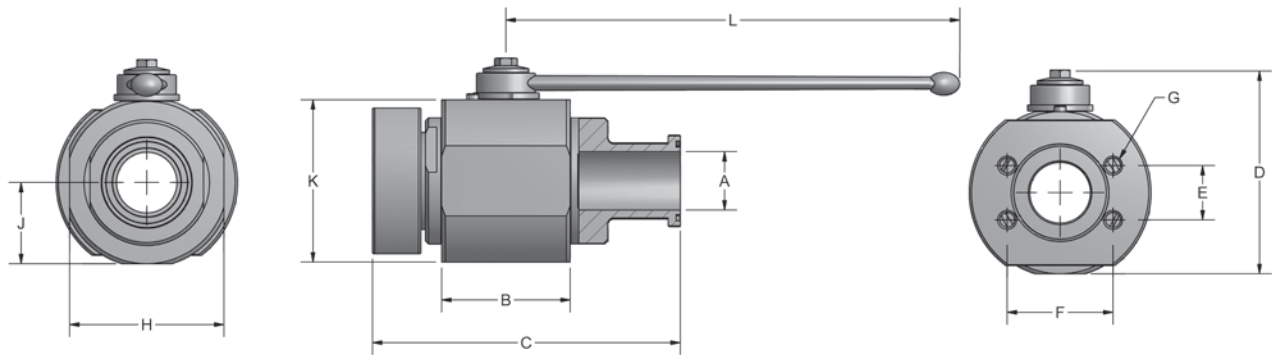

Standard handles supplied are: #8 C1010ZB
 #12 - #16 C1200ZB
 Refer to page 43 for details. #20 - #32 C92501Z-SW17

AES/F SERIES												
SERIES	PSI MAX	A BORE	B	C	D	E	F	G UNC-2B	H	J	K	L
AES/F3#8	5000	.51	1.91	5.3	2.24	.69	1.50	5/16-18	1.46	.71	1.69	4.33
AES/F6#8	6000	.51	1.91	5.3	2.24	.72	1.59	5/16-18	1.46	.71	1.69	4.33
AES/F3#12	5000	.79	2.46	5.8	2.89	.87	1.87	3/8-16	1.77	.92	2.17	7.09
AES/F6#12	6000	.79	2.46	6.1	2.89	.94	2.00	3/8-16	1.77	.92	2.17	7.09
AES/F3#16	5000	.98	2.62	6.4	3.29	1.03	2.06	3/8-16	2.17	1.16	2.56	7.09
AES/F6#16	5000	.98	2.62	6.8	3.29	1.09	2.25	7/16-14	2.17	1.16	2.56	7.09

ABS/F SERIES												
SERIES	PSI MAX	A BORE	B	C	D	E	F	G UNC-2B	H	J	K	L
ABS/F3#20	4000	1.26	2.96	7.2	4.39	1.19	2.31	7/16-14	2.36	1.83	3.66	11.81
ABS/F6#20	5000	1.26	2.96	7.8	4.39	1.25	2.63	1/2-13	2.36	1.83	3.66	11.81
ABS/F3#24	3000	1.57	3.36	8.0	4.94	1.41	2.75	1/2-13	2.95	2.11	4.21	11.81
ABS/F6#24	5000	1.57	3.36	9.0	4.94	1.44	3.13	5/8-11	2.95	2.11	4.21	11.81
ABS/F3#32	3000	1.97	3.86	8.4	5.22	1.69	3.06	1/2-13	3.35	2.24	4.49	11.81
ABS/F6#32	5000	1.97	3.86	9.5	5.22	1.75	3.81	3/4-10	3.35	2.24	4.49	11.81

Model Code Breakdown

AES/F3 #8 - 1 1 D B

Valve Series

AES/F3	Code 61 Block Body
AES/F6	Code 62 Block Body
ABS/F3	Code 61 Round Body
ABS/F6	Code 62 Round Body

Connection Size

Body & Adapter Material

1	Carbon Steel
2	316 Stainless Steel

Ball & Stem Material

1	Carbon Steel
2	316 Stainless Steel

Locking Kit or Optional Handle Code
(See pages 42 & 43)

Adapter & Stem Seals

B	Buna- Standard
V	Viton (Std on S/S)

Ball & Stem Seats

D	POM- Standard
P	PEEK
N	PA612

Please consult your system's seal manufacturer for recommendation of seal selection, as Anchor Fluid Power does not accept responsibility for seal selection.

MAXIMUM & MINIMUM WORKING TEMPERATURES FOR SEAL MATERIALS

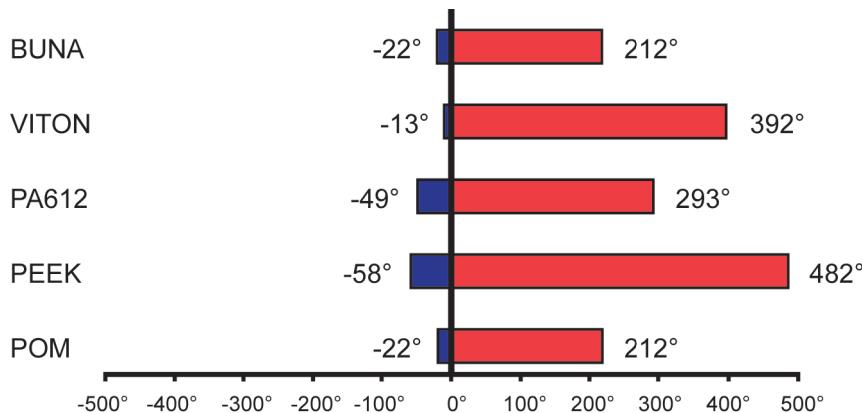

All temperatures are in degrees Fahrenheit.

FLOW, NEEDLE & CHECK VALVES

HYDRAULIC BALL VALVES

WELD COUPLINGS

FLANGES - CARBON STEEL

FLANGES - STAINLESS STEEL

Model Code Breakdown

APK2 #20 - 1 1 D B _

Valve Series

APK2	Manifold Mount 2-way
------	----------------------

Connection Size

20	1/2"
----	------

Body & Adapter Material

1	Carbon Steel
---	--------------

Ball & Stem Material

1	Carbon Steel
---	--------------

Locking Kit or Optional Handle Code
(See pages 42 & 43)

Adapter & Stem Seals

B	Buna- Standard
V	Viton

Ball & Stem Seats

D	POM- Standard
P	PEEK
N	PA612

Please consult your system's seal manufacturer for recommendation of seal selection, as Anchor Fluid Power does not accept responsibility for seal selection.

MAXIMUM & MINIMUM WORKING TEMPERATURES FOR SEAL MATERIALS

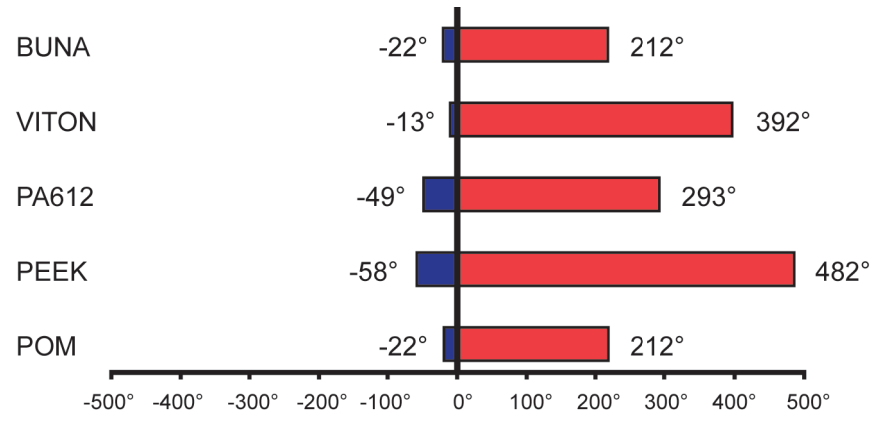

All temperatures are in degrees Fahrenheit.

FLOW, NEEDLE & CHECK VALVES

HYDRAULIC BALL VALVES

WELD COUPLINGS

FLANGES - CARBON STEEL

FLANGES - STAINLESS STEEL

LOCKING KITS AVAILABLE FROM STOCK			
Part Number	Valve Size	Material	Suffix*
LK6	1/8" - 1/2"	Carbon Steel	L
LK20	3/4" - 1"	Carbon Steel	L
LK32	1 1/4" - 2"	Carbon Steel	L
LK6-S/S	1/8" - 1/2"	Stainless Steel	L
LK20-S/S	3/4" - 1"	Stainless Steel	L
LK32-S/S	1 1/4" - 2"	Stainless Steel	L

*Add this suffix to the end of the valve part # to receive the corresponding locking kit for that size valve- installed at the factory. Carbon steel valves receive carbon steel locking kits. Stainless steel valves receive stainless locking kits.

"L" Style Lock

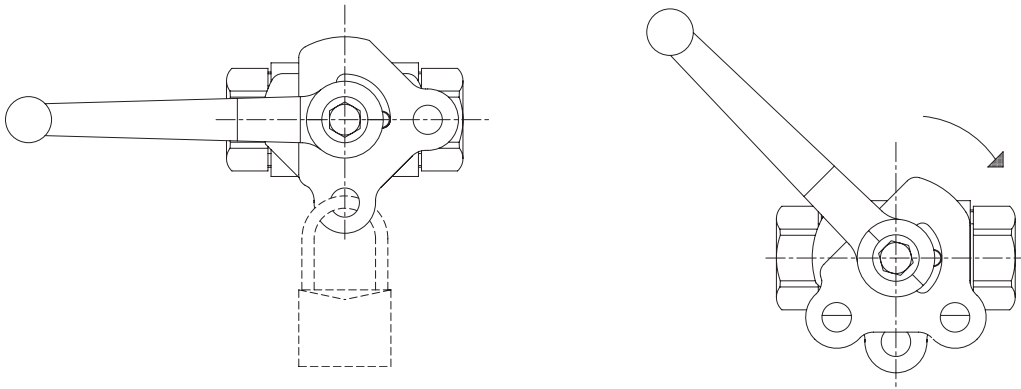

Consult factory for details concerning tamper proof fastener options.

Handles for 1/8" through 1/2" Valves



C0020ZB
Zinc Alloy
Fits 1/8" - 1/2" Valves
5 - 7/8" Long
Code "A"



C1010ZB
Zinc Alloy
Fits 1/8" - 1/2" Valves
4 - 1/4" Long



C10106H
Stainless Steel
Fits 1/8" - 1/2" Valves
4 - 1/4" Long
Code "C"

Handles for 3/4" through 1" Valves



C1200ZB
Zinc Alloy
Fits 3/4" - 1" Valves
7" Long
Code "Z"



C69206H
Stainless Steel
Fits 3/4" - 1" Valves
7 - 7/8" Long
Code "W"



C2950AV
Aluminum
Fits 3/4" - 1" Valves
8" Long
Code "Y"

Handles for 1 1/4" through 2" Valves



C81306H-SW17
Stainless Steel
Fits 1 1/4" - 2" Valves
11 - 3/4" Long
Code "F"



C81302B-SW17
Carbon Steel
Fits 1 1/4" - 2" Valves
11 - 3/4" Long
Code "E"



C92506H-SW17
Stainless Steel
Fits 1 1/4" - 2" Valves
12 - 1/8" Long
Code "J"



C92501Z-SW17
Carbon Steel
Fits 1 1/4" - 2" Valves
12 - 1/8" Long
Code "H"

Dimensions are approximate and are subject to change without notice. For exact dimensional info, please consult the factory with the specific handle part #.

FLOW, NEEDLE & CHECK VALVES

HYDRAULIC BALL VALVES

WELD COUPLINGS

FLANGES - CARBON STEEL

FLANGES - STAINLESS STEEL



All stainless steel construction
 Locking handles standard
 Ideal for suction, pressure and return lines
 Available in NPT & SAE threads
 Mounting holes standard on SAE #16 - #32

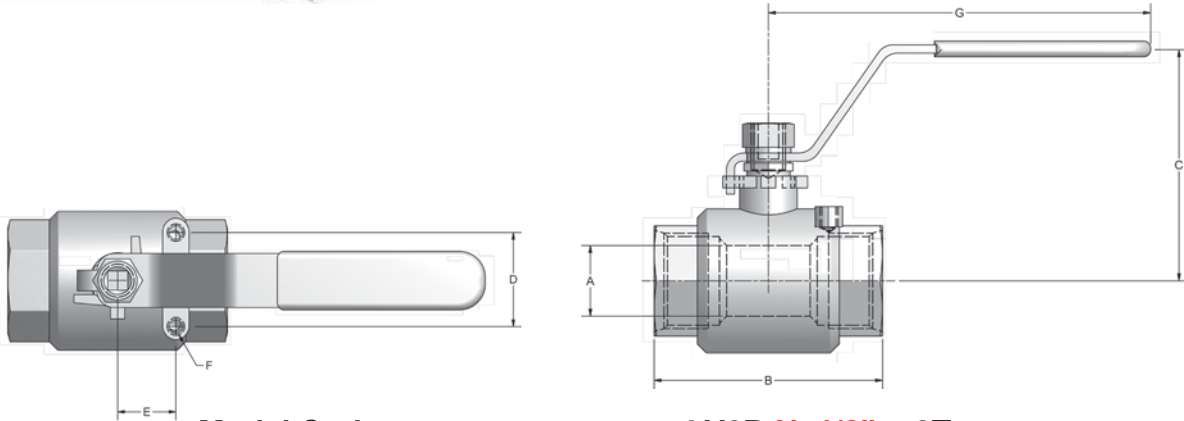

Model Code:

LV2B N 1/2" -2T

Thread type (N-NPT; S-SAE)

Thread size (Ex. N1/2"; S#8)

LV2B SERIES - NPT							
SIZE	A	B	C	D	E	F UNC	G
1/4"	.36	2.13	2.13	1.12	.49	10-24	4.33
3/8"	.50	2.13	2.17	1.12	.49	10-24	4.33
1/2"	.59	2.24	2.28	1.12	.49	10-24	4.53
3/4"	.79	2.68	2.40	1.12	.49	10-24	4.53
1"	.98	3.15	3.03	1.38	.91	1/4-20	5.04
1-1/4"	1.26	3.58	3.19	1.48	1.00	1/4-20	5.04
1-1/2"	1.50	4.06	3.54	1.48	1.00	1/4-20	6.10
2"	1.97	4.88	4.25	1.50	1.00	1/4-20	6.10
2-1/2"	2.56	6.30	5.20	N/A	N/A	N/A	9.06
3"	3.15	7.28	5.71	N/A	N/A	N/A	9.06

LV2B SERIES - SAE							
SIZE	A	B	C	D	E	F UNC	G
1/4"	.35	2.40	2.13	1.12	.49	10-24	4.33
3/8"	.47	2.40	2.17	1.12	.49	10-24	4.33
1/2"	.59	2.52	2.28	1.12	.49	10-24	4.53
3/4"	.79	3.23	2.40	1.12	.49	10-24	4.53
1"	.98	3.62	3.03	1.38	.91	1/4-20	5.04
1-1/4"	1.26	3.96	3.19	1.48	1.00	1/4-20	5.04
1-1/2"	1.50	4.23	3.54	1.48	1.00	1/4-20	6.10
2"	1.97	4.90	4.25	1.50	1.00	1/4-20	6.10

COMPONENT MATERIALS		
COMPONENT	MATERIAL	
VALVE BODY	ASTM A351 GR CF8M	1
TAILPIECE	ASTM A351 GR CF8M	1
BALL	ASTM A351 GR CF8M	1
STEM	316	1
BALL SEAT	PTFE	2
STEM SEAT	PTFE	1
STEM PACKING	PTFE	1
STEM GLAND	304	1
HANDLE	304	1
STEM LOCK WASHER	304	1
STEM NUT	304	1
HANDLE SLEEVE	VINYL	1
LOCK	304	1

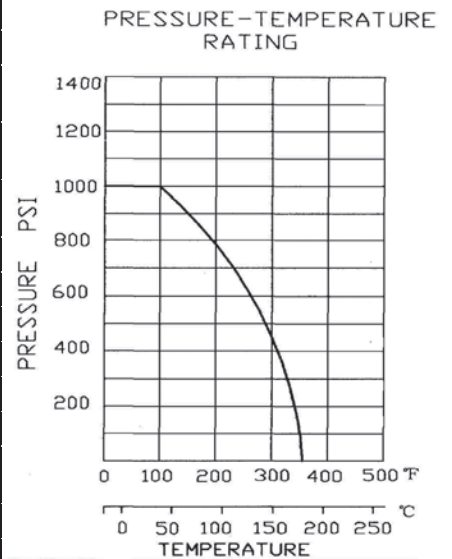

All stainless steel construction
 Locking handles standard
 Ideal for suction, pressure and return lines
 Available in NPT & SAE threads

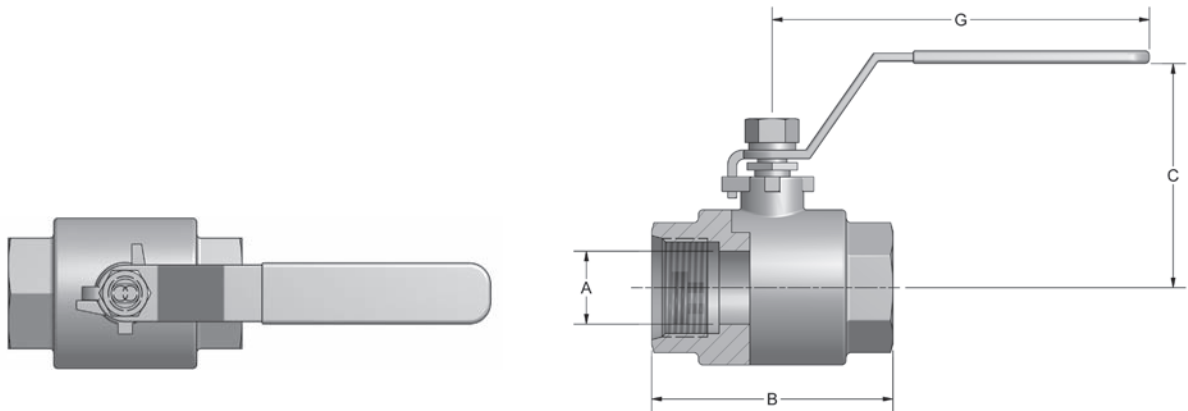

Model Code: **MV2B N 1/2" -2T**

Thread type (**N**-NPT; **S**-SAE)

Thread size (Ex. **N1/2"**; **S#8**)

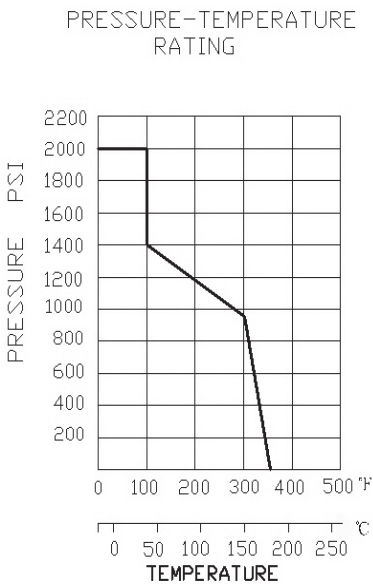

COMPONENT MATERIALS		
COMPONENT	MATERIAL	
VALVE BODY	ASTM A351 GR CF8M	1
TAILPIECE	ASTM A351 GR CF8M	1
BALL	ASTM A351 GR CF8M	1
STEM	316	1
BALL SEAT	PTFE	2
STEM SEAT	PTFE	1
STEM PACKING	PTFE	1
STEM GLAND	304	1
HANDLE	304	1
STEM LOCK WASHER	304	1
STEM NUT	304	1
HANDLE SLEEVE	VINYL	1
LOCK	304	1

MV2B SERIES - NPT				
SIZE	A	B	C	G
1/4"	.36	2.13	2.13	4.33
3/8"	.50	2.13	2.17	4.33
1/2"	.59	2.24	2.28	4.53
3/4"	.79	2.76	2.40	4.53
1"	.98	3.25	3.03	5.04
1-1/4"	1.26	3.58	3.19	5.04
1-1/2"	1.50	4.06	3.54	6.10
2"	1.97	4.90	4.25	6.10

MV2B SERIES - SAE				
SIZE	A	B	C	G
1/4"	.35	2.40	2.13	4.33
3/8"	.47	2.40	2.17	4.33
1/2"	.59	2.52	2.28	4.53
3/4"	.79	3.23	2.40	4.53
1"	.98	3.62	3.03	5.04
1-1/4"	1.26	3.96	3.19	5.04
1-1/2"	1.50	4.23	3.54	6.10
2"	1.97	4.90	4.25	6.10

FLOW, NEEDLE & CHECK VALVES

HYDRAULIC BALL VALVES

WELD COUPLINGS

FLANGES - CARBON STEEL

FLANGES - STAINLESS STEEL



Notes

FLOW, NEEDLE & CHECK VALVES

HYDRAULIC BALL VALVES

WELD COUPLINGS

FLANGES - CARBON STEEL

FLANGES - STAINLESS STEEL

Lined area for notes



Lined area for notes

FLOW, NEEDLE & CHECK VALVES

HYDRAULIC BALL VALVES

WELD COUPLINGS

FLANGES - CARBON STEEL

FLANGES - STAINLESS STEEL

FLOW, NEEDLE & CHECK VALVES

HYDRAULIC BALL VALVES

WELD COUPLINGS

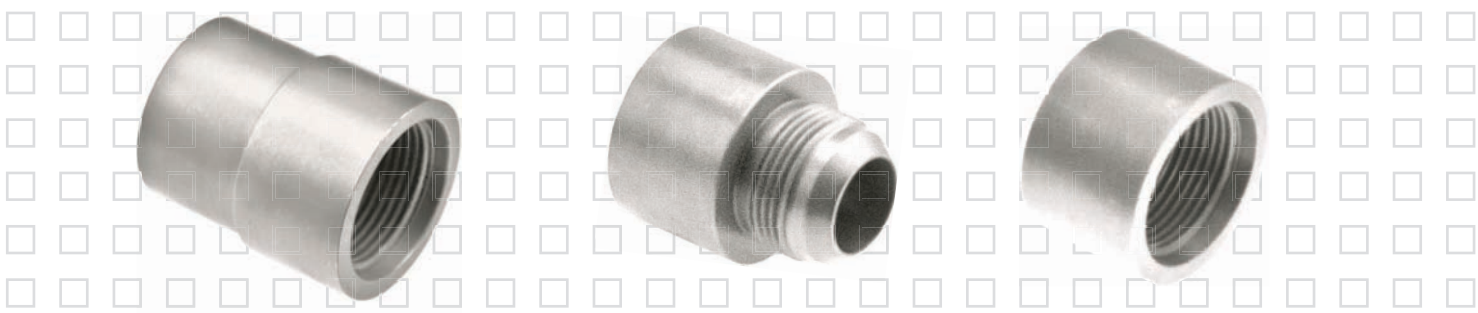

FLANGES - CARBON STEEL

FLANGES - STAINLESS STEEL

SAE Full Couplings _____	50
SAE Half Couplings _____	51
NPTF Full Couplings _____	52
NPTF Half Couplings _____	53
BSPP Full Couplings _____	54
BSPP Half Couplings _____	55
ISO 6149 Metric Couplings _____	56
Socket Weld Couplings _____	57

FLOW, NEEDLE & CHECK VALVES

HYDRAULIC BALL VALVES

WELD COUPLINGS

FLANGES - CARBON STEEL

FLANGES - STAINLESS STEEL

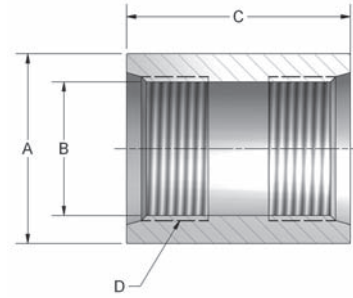
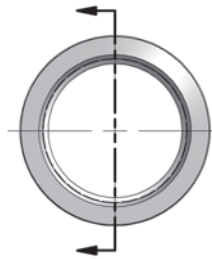

SAE TO SAE FULL COUPLING					
CARBON STEEL PART NO.	STAINLESS STEEL PART NO.	A	B	C	D SAE UN-2B
830-4	830-4-SS	0.88	0.39	1.16	*7/16-20
830-6	830-6-SS	1.00	.508	1.25	*9/16-18
830-8	830-8-SS	1.25	.689	1.63	*3/4-16
830-10	830-10-SS	1.38	.806	1.50	*7/8-14
830-12	830-12-SS	1.50	.981	2.06	1 1/16-12
830-14	830-14-SS	1.63	1.106	2.00	1 3/16-12
830-16	830-16-SS	1.75	1.231	2.06	1 5/16-12
830-20	830-20-SS	2.25	1.544	2.06	1 5/8-12
830-24	830-24-SS	2.75	1.794	2.20	1 7/8-12
830-32	830-32-SS	3.25	2.419	2.50	2 1/2-12
830-40	830-40-SS	3.75	2.92	3.00	3-12
830-48	830-48-SS	4.40	3.42	3.00	3 1/2-12
830-64	830-64-SS	5.25	4.42	3.25	4 1/2-12

AISI1020 Carbon Steel
316L Stainless Steel

Includes individual thread identification marking
Additional thread sizes and configurations available

*UNF-2B

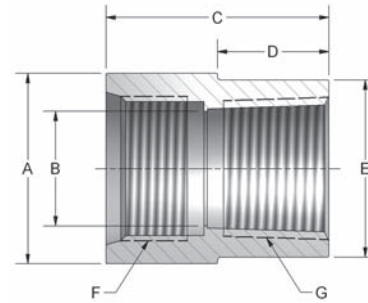
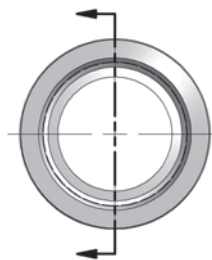

SAE TO NPTF FULL COUPLING								
CARBON STEEL PART NO.	STAINLESS STEEL PART NO.	A	B	C	D	E	F SAE UN-2B	G NPTF
825-4	825-4-SS	1.00	.389	1.27	.64	.875	*7/16-20	1/4-18
825-6	825-6-SS	1.13	.508	1.50	.75	1.000	*9/16-18	3/8-18
825-8	825-8-SS	1.25	.650	1.63	.82	1.125	*3/4-16	1/2-14
825-10-12	825-10-12-SS	1.50	.806	1.75	.88	1.375	*7/8-14	3/4-14
825-12	825-12-SS	1.50	.850	2.06	1.03	1.375	1 1/16-12	3/4-14
825-14-16	825-14-16-SS	1.75	1.050	2.15	1.08	1.625	1 3/16-12	1-11.5
825-16	825-16-SS	1.75	1.050	2.06	1.03	1.625	1 5/16-12	1-11.5
825-20	825-20-SS	2.25	1.420	2.06	1.03	2.125	1 5/8-12	1 1/4-11.5
825-24	825-24-SS	2.75	1.650	2.20	1.10	2.500	1 7/8-12	1 1/2-11.5
825-32	825-32-SS	3.25	2.125	2.50	1.25	3.000	2 1/2-12	2-11.5
825-40	825-40-SS	3.75	2.38	3.00	1.50	3.50	3-2	2 1/2-8
825-48	825-48-SS	4.40	3.00	3.00	1.50	4.00	3 1/2-12	3-8
825-64	825-64-SS	5.25	4.00	3.25	1.63	5.00	4 1/2-12	4-8

AISI1020 Carbon Steel
316L Stainless Steel

Includes individual thread identification marking
Additional thread sizes and configurations available

*UNF-2B

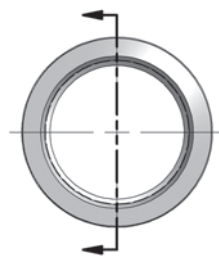
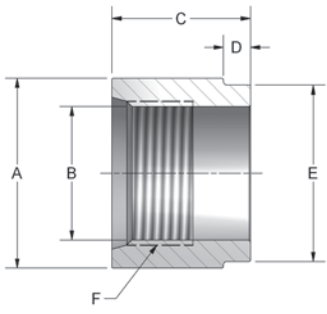

SAE HALF COUPLING							
CARBON STEEL PART NO.	STAINLESS STEEL PART NO.	A	B	C	D	E	F SAE UN-2B
835-4	835-4-SS	.88	.389	1.00	.250	.750	*7/16-20
835-6	835-6-SS	1.00	.508	1.00	.250	.875	*9/16-18
835-8	835-8-SS	1.25	.689	1.06	.250	1.125	*3/4-16
835-10	835-10-SS	1.38	.806	1.06	.250	1.250	*7/8-14
835-12	835-12-SS	1.50	.981	1.28	.250	1.375	1 1/16-12
835-14	835-14-SS	1.63	1.106	1.25	.250	1.500	1 3/16-12
835-16	835-16-SS	1.75	1.231	1.28	.250	1.625	1 5/16-12
835-20	835-20-SS	2.25	1.544	1.28	.250	2.125	1 5/8-12
835-24	835-24-SS	2.75	1.794	1.28	.250	2.500	1 7/8-12
835-32	835-32-SS	3.25	2.419	1.50	.250	3.000	2 1/2-12
835-40	835-40-SS	3.75	2.92	2.00	.250	3.500	3-12
835-48	835-48-SS	4.40	3.42	2.25	.250	4.000	3 1/2-12
835-64	835-64-SS	5.25	4.42	2.25	.250	5.000	4 1/2-12

AISI1020 Carbon Steel
 316L Stainless Steel
 Includes individual thread identification marking
 Additional thread sizes and configurations available

*UNF-2B

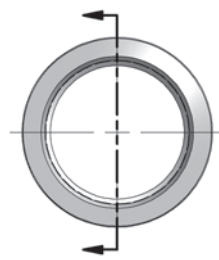
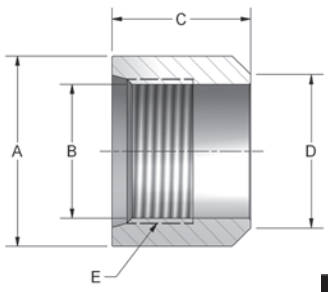

SAE HALF COUPLING BEVEL						
CARBON STEEL PART NO.	STAINLESS STEEL PART NO.	A	B	C	D	E SAE UN-2B
835B-4	835B-4-SS	.88	.389	1.00	.570	*7/16-20
835B-6	835B-6-SS	1.00	.508	1.00	.690	*9/16-18
835B-8	835B-8-SS	1.25	.689	1.06	.870	*3/4-16
835B-10	835B-10-SS	1.38	.806	1.06	.990	*7/8-14
835B-12	835B-12-SS	1.50	.981	1.28	1.160	1 1/16-12
835B-14	835B-14-SS	1.63	1.106	1.25	1.290	1 3/16-12
835B-16	835B-16-SS	1.75	1.231	1.28	1.410	1 5/16-12
835B-20	835B-20-SS	2.25	1.544	1.28	1.720	1 5/8-12
835B-24	835B-24-SS	2.75	1.794	1.28	1.980	1 7/8-12
835B-32	835B-32-SS	3.25	2.419	1.50	2.600	2 1/2-12
835B-40	835B-40-SS	3.75	2.92	2.00	3.000	3-12
835B-48	835B-48-SS	4.40	3.42	2.25	3.500	3 1/2-12
835B-64	835B-64-SS	5.25	4.42	2.25	4.500	4 1/2-12

AISI1020 Carbon Steel
 316L Stainless Steel
 Includes individual thread identification marking
 Additional thread sizes and configurations available

*UNF-2B

FLOW, NEEDLE & CHECK VALVES

HYDRAULIC BALL VALVES

WELD COUPLINGS

FLANGES - CARBON STEEL

FLANGES - STAINLESS STEEL

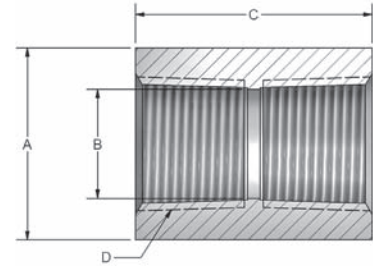
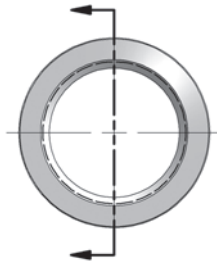

NPTF TO NPTF FULL COUPLING					
CARBON STEEL PART NO.	STAINLESS STEEL PART NO.	A	B	C	D BSPP
865-4	865-4-SS	.88	.391	1.25	1/4-18
865-6	865-6-SS	1.00	.520	1.50	3/8-18
865-8	865-8-SS	1.25	.650	1.85	1/2-14
865-12	865-12-SS	1.50	.850	1.85	3/4-14
865-16	865-16-SS	1.75	1.050	2.35	1-11.5
865-20	865-20-SS	2.25	1.420	2.35	1 1/4-11.5
865-24	865-24-SS	2.75	1.560	2.35	1 1/2-11.5
865-32	865-32-SS	3.25	2.125	2.35	2-11.5

AISI1020 Carbon Steel

316L Stainless Steel

Includes individual thread identification marking

Additional thread sizes and configurations available

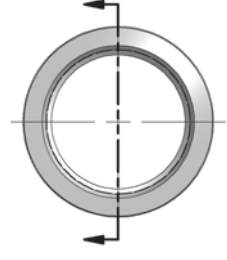
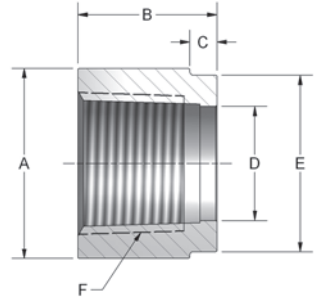

NPTF HALF COUPLING							
CARBON STEEL PART NO.	STAINLESS STEEL PART NO.	A	B	C	D	E	F NPTF
845-4	845-4-SS	.88	1.06	.250	.391	.750	1/4-18
845-6	845-6-SS	1.00	1.00	.250	.563	.875	3/8-18
845-8	845-8-SS	1.25	1.06	.250	.650	1.125	1/2-14
845-12	845-12-SS	1.50	1.28	.250	.850	1.375	3/4-14
845-16	845-16-SS	1.75	1.28	.250	1.050	1.625	1-11.5
845-20	845-20-SS	2.25	1.28	.250	1.420	2.125	1 1/4-11.5
845-24	845-24-SS	2.75	1.28	.250	1.560	2.500	1 1/2-11.5
845-32	845-32-SS	3.25	1.50	.250	2.125	3.000	2-11.5
845-40	845-40-SS	3.75	2.00	.250	2.500	3.500	2 1/2-8
845-48	845-48-SS	4.25	2.25	.250	3.000	4.000	3-8
845-64	845-64-SS	5.25	2.25	.250	4.000	5.000	4-8

AISI1020 Carbon Steel
 316L Stainless Steel
 Includes individual thread identification marking
 Additional thread sizes and configurations available

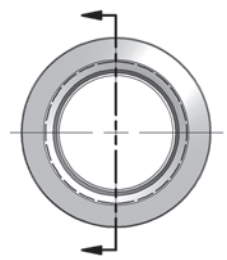
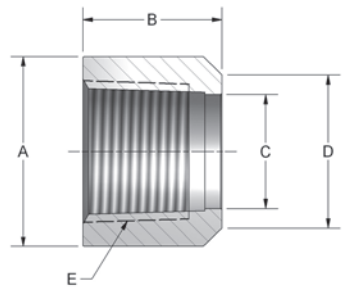

NPTF HALF COUPLING BEVEL						
CARBON STEEL PART NO.	STAINLESS STEEL PART NO.	A	B	C	D	E NPTF
845B-4	845B-4-SS	.88	1.06	.391	.570	1/4-18
845B-6	845B-6-SS	1.00	1.00	.520	.690	3/8-18
845B-8	845B-8-SS	1.25	1.06	.650	.870	1/2-14
845B-12	845B-12-SS	1.50	1.28	.850	1.160	3/4-14
845B-16	845B-16-SS	1.75	1.28	1.050	1.410	1-11.5
845B-20	845B-20-SS	2.25	1.28	1.420	1.720	1 1/4-11.5
845B-24	845B-24-SS	2.75	1.28	1.560	1.980	1 1/2-11.5
845B-32	845B-32-SS	3.25	1.50	2.125	2.600	2-11.5
845B-40	845B-40-SS	3.75	2.00	2.500	3.100	2 1/2-8
845B-48	845B-48-SS	4.40	2.25	3.000	3.600	3-8
845B-64	845B-64-SS	5.25	2.25	4.000	4.450	4-8

AISI1020 Carbon Steel
 316L Stainless Steel
 Includes individual thread identification marking
 Additional thread sizes and configurations available

FLOW, NEEDLE & CHECK VALVES

HYDRAULIC BALL VALVES

WELD COUPLINGS

FLANGES - CARBON STEEL

FLANGES - STAINLESS STEEL

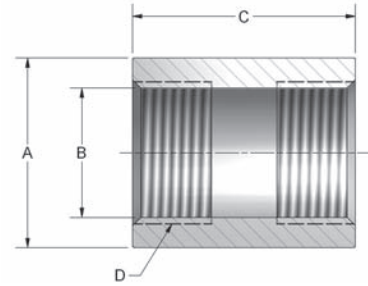
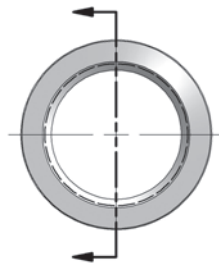

BSPP TO BSPP FULL COUPLING					
CARBON STEEL PART NO.	STAINLESS STEEL PART NO.	A	B	C	D BSPP
850-4	850-4-SS	.88	.451	1.25	1/4-19
850-6	850-6-SS	1.00	.589	1.25	3/8-19
850-8	850-8-SS	1.25	.734	1.63	1/2-14
850-12	850-12-SS	1.50	.950	2.06	3/4-14
850-16	850-16-SS	1.75	1.193	2.06	1-11
850-20	850-20-SS	2.25	1.534	2.06	1 1/4-11
850-24	850-24-SS	2.75	1.766	2.20	1 1/2-11
850-32	850-32-SS	3.25	2.231	2.50	2-11

AISI1020 Carbon Steel
316L Stainless Steel

Includes individual thread identification marking
Additional thread sizes and configurations available

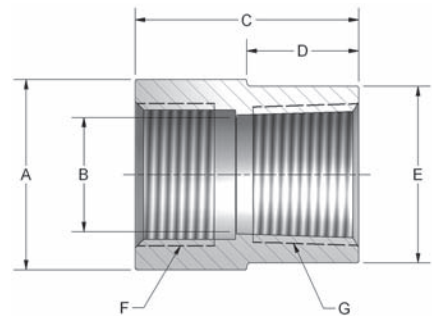
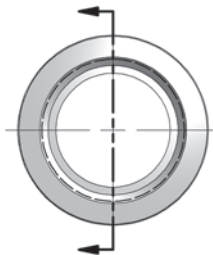

BSPP TO NPTF FULL COUPLING								
CARBON STEEL PART NO.	STAINLESS STEEL PART NO.	A	B	C	D	E	F BSPP	G NPTF
860-4	860-4-SS	1.00	.400	1.27	.64	.875	1/4-19	1/4-18
860-6	860-6-SS	1.13	.507	1.50	.75	1.000	3/8-19	3/8-18
860-8	860-8-SS	1.25	.650	1.63	.82	1.125	1/2-14	1/2-14
860-12	860-12-SS	1.50	.850	2.06	1.03	1.375	3/4-14	3/4-14
860-16	860-16-SS	1.75	1.050	2.06	1.03	1.625	1-11	1-11.5
860-20	860-20-SS	2.25	1.500	2.06	1.03	2.125	1 1/4-11	1 1/4-11.5
860-24	860-24-SS	2.75	1.750	2.20	1.10	2.500	1 1/2-11	1 1/2-11.5
860-32	860-32-SS	3.25	2.125	2.50	1.25	3.000	2-11	2-11.5

AISI1020 Carbon Steel
316L Stainless Steel

Includes individual thread identification marking
Additional thread sizes and configurations available

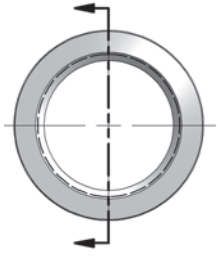
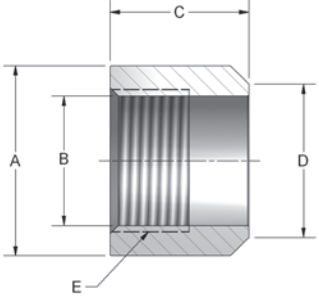

BSPB HALF COUPLING BEVEL						
CARBON STEEL PART NO.	STAINLESS STEEL PART NO.	A	B	C	D	E BSPP
855B-4	855B-4-SS	.88	.451	1.00	.570	1/4-19
855B-6	855B-6-SS	1.00	.589	1.00	.690	3/8-19
855B-8	855B-8-SS	1.25	.734	1.06	.870	1/2-14
855B-12	855B-12-SS	1.50	.950	1.28	1.160	3/4-14
855B-16	855B-16-SS	1.75	1.193	1.28	1.410	1-11
855B-20	855B-20-SS	2.25	1.534	1.28	1.720	1 1/4-11
855B-24	855B-24-SS	2.75	1.766	1.28	1.980	1 1/2-11
855B-32	855B-32-SS	3.25	2.231	1.50	2.600	2-11

AISI1020 Carbon Steel
 316L Stainless Steel
 Includes individual thread identification marking
 Additional thread sizes and configurations available

FLOW, NEEDLE & CHECK VALVES

HYDRAULIC BALL VALVES

WELD COUPLINGS

FLANGES - CARBON STEEL

FLANGES - STAINLESS STEEL

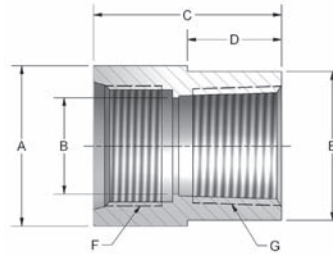
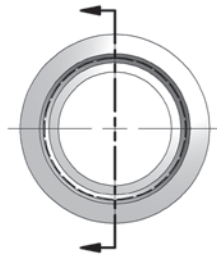

ISO 6149 TO NPTF FULL COUPLING								
CARBON STEEL PART NO.	STAINLESS STEEL PART NO.	A	B	C	D	E	F ISO 6149 METRIC	G NPTF
885-M27-12	885-M27-12-SS	1.50	.850	2.06	1.03	1.375	M27 X 2	3/4-14
885-M33-16	885-M33-16-SS	1.75	1.050	2.06	1.03	1.625	M33 X 2	1-11.5
885-M42-20	885-M42-20-SS	2.25	1.420	2.06	1.03	2.125	M42 X 2	1 1/4-11.5
885-M48-24	885-M48-24-SS	2.75	1.650	2.20	1.10	2.500	M48 X 2	1 1/2-11.5
885-M60-32	885-M60-32-SS	3.25	2.125	2.50	1.25	3.000	M60 X 2	2-11.5

AISI1020 Carbon Steel

316L Stainless Steel

Includes individual thread identification marking

Additional thread sizes and configurations available

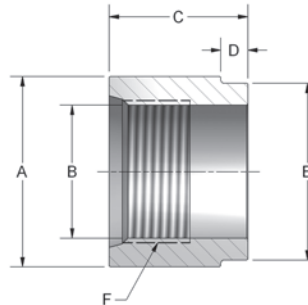
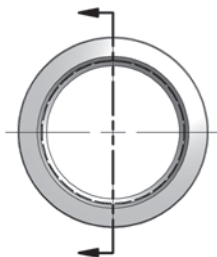

ISO 6149 HALF COUPLING							
CARBON STEEL PART NO.	STAINLESS STEEL PART NO.	A	B	C	D	E	F ISO 6149 METRIC
880-M27	880-M27-SS	1.50	.981	1.28	.250	1.375	M27 X 2
880-M33	880-M33-SS	1.75	1.231	1.28	.250	1.625	M33 X 2
880-M42	880-M42-SS	2.25	1.544	1.28	.250	2.125	M42 X 2
880-M48	880-M48-SS	2.75	1.794	1.28	.250	2.500	M48 X 2
880-M60	880-M60-SS	3.25	2.419	1.50	.250	3.000	M60 X 2

AISI1020 Carbon Steel

316L Stainless Steel

Includes individual thread identification marking

Additional thread sizes and configurations available

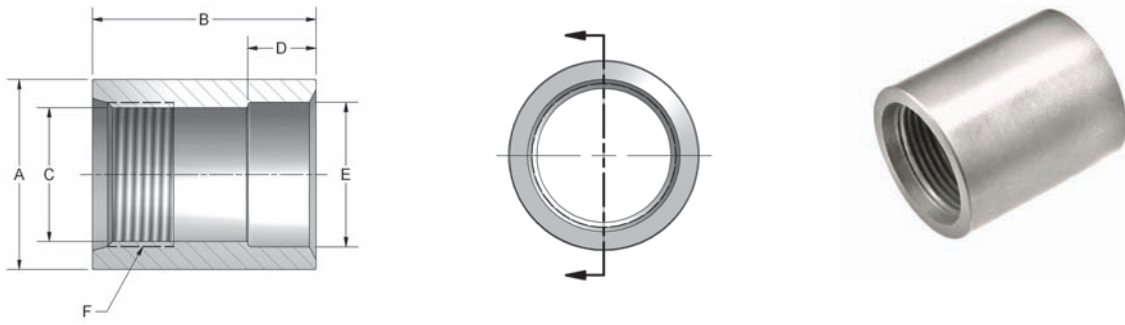

SAE TO SOCKET WELD PIPE COUPLING							
CARBON STEEL PART NO.	STAINLESS STEEL PART NO.	A	B	C	D	E	F SAE UN-2B
820-8	820-8-SS	1.25	1.63	.689	.560	.855	*3/4-16
820-12	820-12-SS	1.50	2.06	.981	.560	1.062	1 1/16-12
820-16	820-16-SS	1.75	2.06	1.231	.630	1.328	1 5/16-12
820-20	820-20-SS	2.25	2.06	1.544	.690	1.672	1 5/8-12
820-24	820-24-SS	2.75	2.20	1.794	.750	1.922	1 7/8-12
820-32	820-32-SS	3.25	2.50	2.419	.875	2.406	2 1/2-12
820-40	820-40-SS	3.09	3.00	2.920	1.000	2.910	3-12
820-48	820-48-SS	3.59	3.00	3.420	1.120	3.550	3 1/2-12
820-64	820-64-SS	4.59	3.25	4.420	1.250	4.580	4 1/2-12

*UNF-2B

AISI1020 Carbon Steel
 316L Stainless Steel
 Includes individual thread identification marking
 Additional thread sizes and configurations available

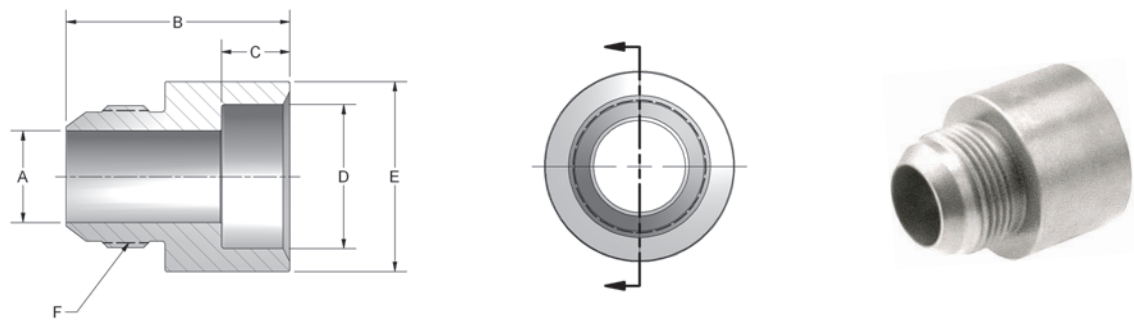

SOCKET WELD PIPE TO MALE JIC COUPLING							
CARBON STEEL PART NO.	STAINLESS STEEL PART NO.	A	B	C	D	E	F SAE UN-2A
840-8	840-8-SS	.394	1.63	.560	.855	1.25	*3/4-16
840-12	840-12-SS	.611	1.89	.560	1.062	1.50	1 1/16-12
840-16	840-16-SS	.844	2.06	.630	1.328	1.75	1 5/16-12
840-20	840-20-SS	1.078	2.06	.690	1.672	2.25	1 5/8-12
840-24	840-24-SS	1.318	2.20	.750	1.922	2.75	1 7/8-12
840-32	840-32-SS	1.781	2.50	.875	2.406	3.25	2 1/2-12

*UNF-2A

AISI1020 Carbon Steel
 316L Stainless Steel
 Includes individual thread identification marking
 Additional thread sizes and configurations available

FLOW, NEEDLE & CHECK VALVES

HYDRAULIC BALL VALVES

WELD COUPLINGS

FLANGES - CARBON STEEL

FLANGES - STAINLESS STEEL

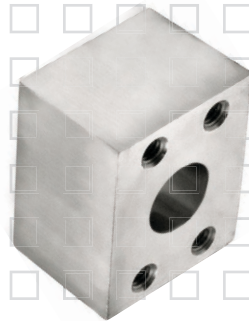

SAE J518 Split/Captive Flanges

FOR SAE FLANGED HEAD CONNECTION

CD 61 - CD 62 _____	64
---------------------	----

Split Flange Head Adapters

CD 61 - CD 62 JIC Thread _____	65
CD 61 - CD 62 SAE Straight Thread _____	65
CD 61 - CD 62 ORFS Thread _____	66
CD 61 - CD 62 45° Elbow JIC Thread _____	66
CD 61 - CD 62 45° Elbow ORFS Thread _____	66
CD 61 - CD 62 90° Elbow JIC Thread _____	67
CD 61 - CD 62 90° Elbow ORFS Thread _____	67
CD 61 Butt Weld-Sched 40/Sched 80/Sched 160 _____	68
CD 62 Butt Weld-Sched 80/Sched 160/Sched XXS _____	69
CD 61 - CD 62 Socket Weld _____	70
CD 61 NPTF Thread _____	70
CD 61 SAE Thread _____	70
CD 61 - CD 62 Braze-On _____	71
CD 61 - CD 62 Flange Plug _____	75

SAE 4 Bolt Flanges

CD 61 - CD 62 Spacer Blocks with Gage Port _____	78
CD 61 - CD 62 Blanking _____	81
CD 61 - CD 62 NPTF _____	83
CD 61 - CD 62 SAE Thread _____	84
CD 61 - CD 62 BSPP Thread _____	85
CD 61 - CD 62 Male JIC _____	86
CD 61 - CD 62 Male ORFS _____	87
CD 61 - CD 62 Flat Socket Weld Pipe _____	88
CD 61 - CD 62 Flat Socket Weld Tube _____	89
CD 61 - CD 62 Deep Socket Weld Pipe _____	90
CD 61 - CD 62 Deep Socket Weld Tube _____	91
CD 61 Butt Weld-Sched 40/Sched 80/Sched 160 _____	92
CD 62 Butt Weld-Sched 80/Sched 160/Sched XXS _____	93
CD 61 Saddle Weld _____	94
CD 61 Tank Pilot _____	95
CD 61 - CD 62 Elbow Block _____	96
CD 61 - CD 62 Elbow NPTF & SAE Thread _____	98
CD 61 Elbow Socket Weld Pipe _____	99
CD 62 Elbow Socket Weld Tube _____	100

Square 4 Bolt Flanges

3000 Series Flat Socket Weld _____	101
3000 Series NPTF Thread _____	101
6000 Series Flat Socket Weld _____	102

Miscellaneous Components

CAT-Style Split Flange _____	74
CD 61 - CD 62 Braze-On ORFS Thread _____	72
CD 61 - CD 62 Braze-On JIC Thread _____	73
CD 61 - CD 62 Connector Plates _____	76
CD 61 - CD 62 Connector Blocks _____	76
CD 61 - CD 62 Double O-Ring Union _____	77
CD 61 - CD 62 Orifice Plate _____	79
CD 61 - CD 62 Bolt Pattern Adapter _____	80
CD 61 - CD 62 Shipping Plates _____	82
CD 61 - CD 62 Tee Junction Block _____	97
O-Rings _____	119

Split Flange Adapters

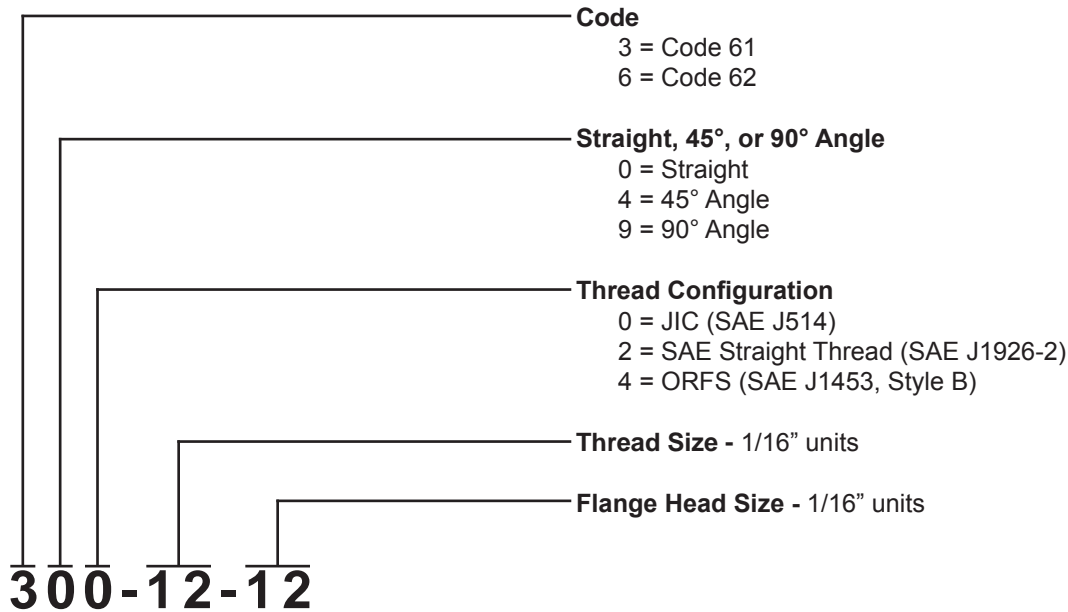

For additional jump sizes, please consult factory.

Flanges

Our basic part numbering system is simple to use. The explanation of our part numbering system is detailed below. The series number provides the greatest amount of information pertaining to the flange product. The port size and pad size simply refer to size only, with all sizes based on 1/16 of an inch.

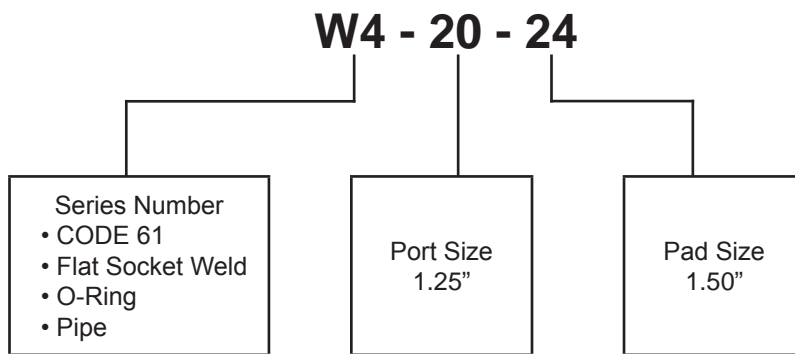

NOTE #1 – All items available with mounting kit by simply adding suffix letter "U".

NOTE #2 – All items available in stainless steel material by simply adding the suffix letters "SS".

NOTE #3 – All items available with metric mounting holes simply by adding the appropriate suffix (IE: M10, M12, etc.).

Pressure Ratings of SAE Flanges

CODE 61 SAE J518-1 / ISO 6162-1					
Dash Size	Inch Size	Max Working Pressure		Grade 8 and Equivalent Fastener Torque Value	
		PSI	MPa	Socket Head UNC (lb-ft)	Hex Head UNC (lb-ft)
-8	1/2"	5000	35	24	18
-12	3/4"	5000	35	44	33
-16	1"	4600	32	44	33
-20	1 1/4"	4000	28	68	52
-24	1 1/2"	3000	21	111	80
-32	2"	3000	21	111	80
-40	2 1/2"	2500	17.5	111	80
-48	3"	2300	16	218	160
-56	3 1/2"	500	3.5	218	160
-64	4"	500	3.5	218	160
-80	5"	500	3.5	218	160

CODE 62 SAE J518-2 / ISO 6162-2					
Dash Size	Inch Size	Max Working Pressure		Grade 8 and Equivalent Fastener Torque Value	
		PSI	MPa	Socket Head UNC (lb-ft)	Hex Head UNC (lb-ft)
-8	1/2"	6000	40	24	18
-12	3/4"	6000	40	44	33
-16	1"	6000	40	68	52
-20	1 1/4"	6000	40	111	80
-24	1 1/2"	6000	40	218	160
-32	2"	6000	40	332	281

**All max working pressures listed above are specific to the SAE J518/ISO 6162 bolt pattern. Features within the 4-Bolt flange and the connection opposite the 4-Bolt flange can de-rate the maximum working pressure.

NOTE - All carbon steel torque values are based on AFP supplied socket head and hex head fasteners. Use of alternate fasteners can affect torque value. Consult factory for additional information.

Split Flange Clamp

1 Clean the sealing surfaces and make certain they are free from nicks, scratches and burrs. Foreign material prevents a proper seal.

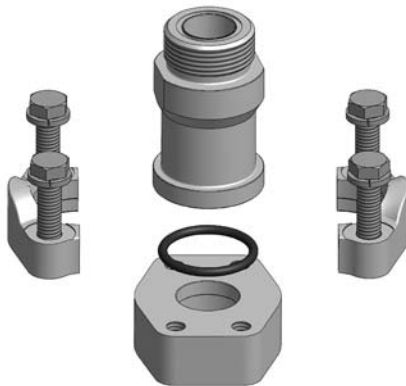

2 Lubricate the o-ring and ensure that it is properly installed as to prevent damage during installation.

3 Push the flange clamps towards the flange head and screw fasteners into flange pad. Continue to screw the fasteners until their heads just meet the split flange surface.

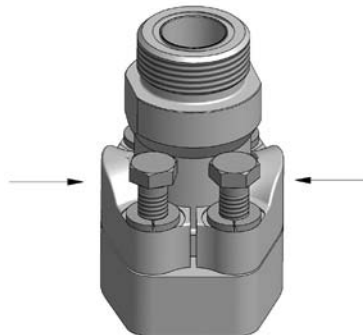

4 Torque the fasteners in diagonal sequence, in small increments, until final torque level is achieved. Torque values for flange connections listed above. Notice that the torque values vary according to size and fastener type.

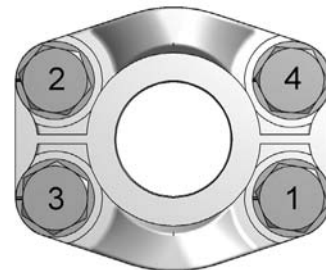

Anchor Fluid Power split flange connections are manufactured according to SAE J518-1 and -2, as well as ISO 6162-1 and -2. These standards control dimensions, tolerances and plating. Please note that the above pressure rating chart refers to the flange connection. Adapting the flange to other connections, such as braze tube, welded pipe, or threaded ports / stud ends, could reduce maximum working pressure. Please consult with Anchor Fluid Power for pressure rating specific to your connection requirement.

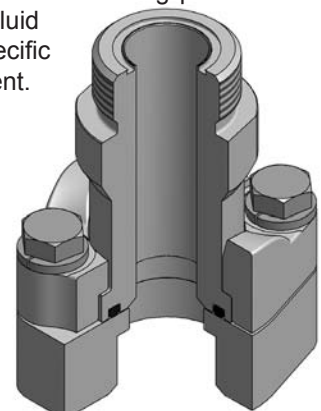

FLOW, NEEDLE & CHECK VALVES

HYDRAULIC BALL VALVES

WELD COUPLINGS

FLANGES - CARBON STEEL

FLANGES - STAINLESS STEEL



FLOW, NEEDLE & CHECK VALVES

HYDRAULIC BALL VALVES

WELD COUPLINGS

FLANGES - CARBON STEEL

FLANGES - STAINLESS STEEL

CODE 61 SPLIT FLANGE													
*PART NO.	**KIT PART NO.	FLANGE SIZE	A	B	C	D	E	F	G	H	J	MOUNTING HARDWARE	
												O-RING	HHCS
8SF-2	8SFO	.50	.86	2.12	1.500	.75	.50	1.219	.955	.245	.344	210	5/16-18X1.25
12SF-2	12SFO	.75	.98	2.56	1.875	.88	.56	1.531	1.265	.245	.406	214	3/8-16X1.25
16SF-2	16SFO	1.00	1.11	2.75	2.062	.94	.62	1.781	1.515	.295	.406	219	3/8-16X1.25
20SF-2	20SFO	1.25	1.39	3.12	2.312	.88	.56	2.031	1.720	.295	.469	222	7/16-14X1.50
24SF-2	24SFO	1.50	1.58	3.69	2.750	1.00	.62	2.406	2.000	.295	.531	225	1/2-13X1.50
32SF-2	32SFO	2.00	1.86	4.00	3.062	1.03	.62	2.844	2.470	.355	.531	228	1/2-13X1.50
40SF-2	40SFO	2.50	2.09	4.50	3.500	1.50	.75	3.344	2.950	.355	.531	232	1/2-13X1.75
48SF-2	48SFO	3.00	2.53	5.31	4.188	1.62	.88	4.031	3.580	.355	.656	237	5/8-11X1.75
56SF-2	56SFO	3.50	2.70	6.00	4.750	1.12	.88	4.531	4.030	.422	.656	241	5/8-11X2.00
64SF-2	64SFO	4.00	2.95	6.38	5.125	1.38	1.00	5.031	4.530	.422	.656	245	5/8-11X2.00

CODE 62 SPLIT FLANGE													
*PART NO.	**KIT PART NO.	FLANGE SIZE	A	B	C	D	E	F	G	H	J	MOUNTING HARDWARE	
												O-RING	HHCS
8SFX-2	8SFXO	.50	.89	2.22	1.594	.88	.62	1.281	.970	.285	.344	210	5/16-18X1.25
12SFX-2	12SFXO	.75	1.14	2.81	2.000	1.12	.75	1.656	1.280	.325	.406	214	3/8-16X1.50
16SFX-2	16SFXO	1.00	1.33	3.19	2.250	1.31	.94	1.906	1.530	.355	.469	219	7/16-14X1.75
20SFX-2	20SFXO	1.25	1.48	3.75	2.625	1.50	1.06	2.156	1.750	.385	.531	222	1/2-13X1.75
24SFX-2	24SFXO	1.50	1.83	4.44	3.125	1.69	1.19	2.531	2.030	.475	.656	225	5/8-11X2.25
32SFX-2	32SFXO	2.00	2.20	5.25	3.812	2.06	1.44	3.156	2.660	.475	.781	228	3/4-10X2.75

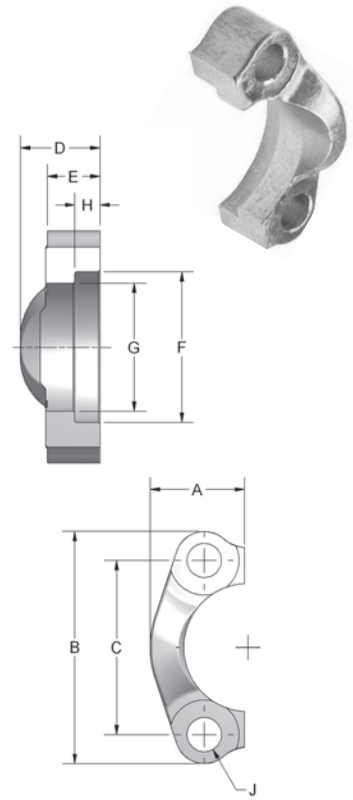

*Anchor part # includes: (1) split flange half only

**Kit part # includes: (2) split flange halves, (4) hex head screws with lockwashers, (1) Buna N O-Ring
Split flange halves are silver trivalent plated

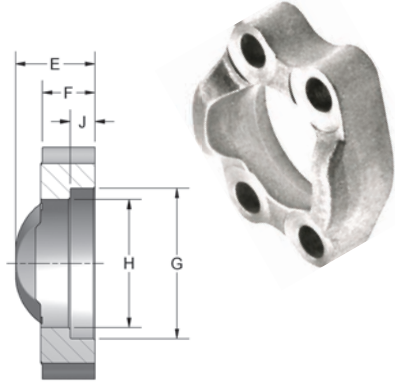

CODE 61 CAPTIVE FLANGE													
DRILLED PART NO.	TAPPED	FLANGE SIZE	A	B	C	D	E	F	G	H	J	K	K UNC-2B
8SFW	8SFTW	.50	1.81	2.12	.688	1.500	.75	.50	1.219	.955	.245	.344	5/16-18
12SFW	12SFTW	.75	2.06	2.56	.875	1.875	.88	.56	1.531	1.265	.245	.406	3/8-16
16SFW	16SFTW	1.00	2.31	2.75	1.031	2.062	.94	.62	1.781	1.515	.295	.406	3/8-16
20SFW	20SFTW	1.25	2.88	3.12	1.188	2.312	.88	.56	2.031	1.720	.295	.469	7/16-14
24SFW	24SFTW	1.50	3.25	3.69	1.406	2.750	1.00	.62	2.406	2.000	.295	.531	1/2-13
32SFW	32SFTW	2.00	3.81	4.00	1.688	3.062	1.03	.62	2.844	2.470	.355	.531	1/2-13
40SFW	40SFTW	2.50	4.28	4.50	2.000	3.500	1.50	.75	3.344	2.950	.355	.531	1/2-13
48SFW	48SFTW	3.00	5.16	5.31	2.438	4.188	1.62	.88	4.031	3.580	.355	.656	5/8-11
56SFW	56SFTW	3.50	5.50	6.00	2.750	4.750	1.12	.88	4.531	4.030	.422	.656	5/8-11
64SFW	64SFTW	4.00	6.00	6.38	3.062	5.125	1.38	1.00	5.031	4.530	.422	.656	5/8-11

CODE 62 CAPTIVE FLANGE													
DRILLED PART NO.	TAPPED	FLANGE SIZE	A	B	C	D	E	F	G	H	J	K	K UNC-2B
8SFXW	8SFXTW	.50	1.86	2.22	.718	1.594	.88	.62	1.281	.970	.285	.344	5/16-18
12SFXW	12SFXTW	.75	2.38	2.81	.937	2.000	1.12	.75	1.656	1.280	.325	.406	3/8-16
16SFXW	16SFXTW	1.00	2.75	3.19	1.093	2.250	1.31	.94	1.906	1.530	.355	.469	7/16-14
20SFXW	20SFXTW	1.25	3.06	3.75	1.250	2.625	1.50	1.06	2.156	1.750	.385	.531	1/2-13
24SFXW	24SFXTW	1.50	3.75	4.44	1.437	3.125	1.69	1.19	2.531	2.030	.475	.656	5/8-11
32SFXW	32SFXTW	2.00	4.50	5.25	1.750	3.812	2.06	1.44	3.156	2.660	.475	.781	3/4-10

Captive Flanges have natural finish

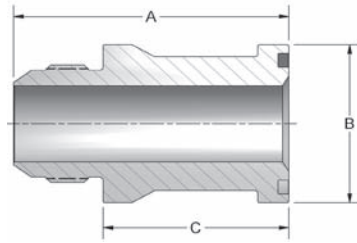

JIC Thread

CODE 61 JIC THREAD						
PART NO.	TUBE O.D.	FLANGE SIZE	A	B	C	THREAD
300-8-8	1/2	1/2	2.60	1.188	1.94	3/4-16
300-8-12	1/2	3/4	2.75	1.500	2.09	3/4-16
300-12-12	3/4	3/4	2.75	1.500	1.89	1 1/16-12
300-16-12	1	3/4	2.75	1.500	1.84	1 5/16-12
300-12-16	3/4	1	2.80	1.750	1.94	1 1/16-12
300-16-16	1	1	2.80	1.750	1.89	1 5/16-12
300-20-16	1 1/4	1	2.80	1.750	1.84	1 5/8-12
300-12-20	3/4	1 1/4	2.80	2.000	1.94	1 1/16-12
300-16-20	1	1 1/4	2.80	2.000	1.89	1 5/16-12
300-20-20	1 1/4	1 1/4	2.80	2.000	1.84	1 5/8-12
300-24-20	1 1/2	1 1/4	3.40	2.000	2.32	1 7/8-12
300-16-24	1	1 1/2	3.33	2.380	2.42	1 5/16-12
300-20-24	1 1/4	1 1/2	3.38	2.375	2.42	1 5/8-12
300-24-24	1 1/2	1 1/2	3.50	2.375	2.42	1 7/8-12
300-32-24	2	1 1/2	4.20	2.375	2.87	2 1/2-12
300-20-32	1 1/4	2	3.60	2.810	2.64	1 5/8-12
300-24-32	1 1/2	2	3.73	2.812	2.64	1 7/8-12
300-32-32	2	2	3.98	2.812	2.64	2 1/2-12
300-32-40	2	2 1/2	3.98	3.312	2.64	2 1/2-12

CODE 62 JIC THREAD						
PART NO.	TUBE O.D.	FLANGE SIZE	A	B	C	THREAD
600-8-8	1/2	1/2	2.61	1.250	1.95	3/4-16
600-12-12	3/4	3/4	2.75	1.625	1.89	1 1/16-12
600-16-12	1	3/4	2.75	1.625	1.84	1 5/16-12
600-20-12	1 1/4	3/4	3.05	1.625	2.09	1 5/8-12
600-12-16	3/4	1	2.80	1.875	1.94	1 1/16-12
600-16-16	1	1	2.80	1.875	1.89	1 5/16-12
600-20-16	1 1/4	1	2.80	1.875	1.84	1 5/8-12
600-16-20	1	1 1/4	3.05	2.125	2.14	1 5/16-12
600-20-20	1 1/4	1 1/4	3.05	2.125	2.09	1 5/8-12
600-24-20	1 1/2	1 1/4	3.30	2.125	2.22	1 7/8-12
600-16-24	1	1 1/2	3.33	2.500	2.42	1 5/16-12
600-20-24	1 1/4	1 1/2	3.50	2.500	2.54	1 5/8-12
600-24-24	1 1/2	1 1/2	3.50	2.500	2.42	1 7/8-12
600-32-24	2	1 1/2	4.49	2.500	3.61	2 1/2-12
600-24-32	1 1/2	2	3.98	3.125	2.89	1 7/8-12
600-32-32	2	2	4.23	3.125	2.89	2 1/2-12

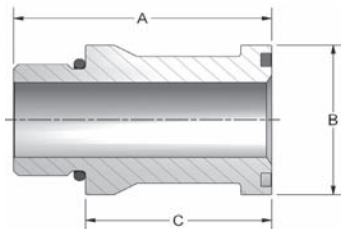

SAE Straight Thread

CODE 61 SAE STRAIGHT THREAD						
PART NO.	TUBE O.D.	FLANGE SIZE	A	B	C	THREAD
302-8-8	1/2	1/2	2.49	1.188	1.94	3/4-16
302-12-12	3/4	3/4	2.61	1.500	1.89	1 1/16-12
302-16-12	1	3/4	2.88	1.500	2.16	1 5/16-12
302-12-16	3/4	1	2.74	1.750	2.02	1 1/16-12
302-16-16	1	1	2.61	1.750	1.89	1 5/16-12
302-20-16	1 1/4	1	3.13	1.750	2.41	1 5/8-12
302-16-20	1	1 1/4	2.74	2.000	2.02	1 5/16-12
302-20-20	1 1/4	1 1/4	3.13	2.000	2.41	1 5/8-12
302-24-20	1 1/2	1 1/4	3.43	2.000	2.71	1 7/8-12
302-16-24	1	1 1/2	3.30	2.380	2.58	1 5/16-12
302-20-24	1 1/4	1 1/2	3.30	2.375	2.58	1 5/8-12
302-24-24	1 1/2	1 1/2	3.14	2.375	2.42	1 7/8-12
302-24-32	1 1/2	2	3.79	2.812	3.07	1 7/8-12
302-32-32	2	2	3.63	2.812	2.91	2 1/2-12
302-40-40	2 1/2	2 1/2	4.23	3.310	3.08	3-12
302-48-48	3	3	4.50	4.000	3.36	3 1/2-12
302-64-64	4	4	4.14	5.000	2.89	4 1/2-12

CODE 62 SAE STRAIGHT THREAD						
PART NO.	TUBE O.D.	FLANGE SIZE	A	B	C	THREAD
602-8-8	1/2	1/2	2.50	1.250	1.95	3/4-16
602-12-12	3/4	3/4	2.62	1.625	1.89	1 1/16-12
602-16-12	1	3/4	2.88	1.625	2.15	1 5/16-12
602-12-16	3/4	1	2.75	1.875	2.02	1 1/16-12
602-16-16	1	1	2.62	1.875	1.89	1 5/16-12
602-20-16	1 1/4	1	3.44	1.875	2.71	1 5/8-12
602-16-20	1	1 1/4	3.12	2.125	2.39	1 5/16-12
602-20-20	1 1/4	1 1/4	3.00	2.125	2.27	1 5/8-12
602-24-20	1 1/2	1 1/4	3.44	2.125	2.71	1 7/8-12
602-20-24	1 1/4	1 1/2	3.31	2.500	2.58	1 5/8-12
602-24-24	1 1/2	1 1/2	3.19	2.500	2.46	1 7/8-12
602-24-32	1 1/2	2	3.90	3.125	3.17	1 7/8-12
602-32-32	2	2	3.75	3.125	3.02	2 1/2-12

FLOW, NEEDLE & CHECK VALVES

HYDRAULIC BALL VALVES

WELD COUPLINGS

FLANGES - CARBON STEEL

FLANGES - STAINLESS STEEL

Threaded

FLOW, NEEDLE & CHECK VALVES

HYDRAULIC BALL VALVES

ORFS Thread

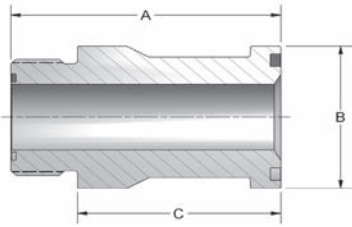

CODE 61 ORFS THREAD						
PART NO.	TUBE O.D.	FLANGE SIZE	A	B	C	THREAD
304-12-12	3/4	3/4	2.75	1.500	2.08	1 3/16-12
304-16-12	1	3/4	2.75	1.500	2.06	1 7/16-12
304-12-16	3/4	1	2.80	1.750	2.13	1 3/16-12
304-16-16	1	1	2.80	1.750	2.11	1 7/16-12
304-20-16	1 1/4	1	2.80	1.750	2.11	1 11/16-12
304-16-20	1	1 1/4	2.80	2.000	2.11	1 7/16-12
304-20-20	1 1/4	1 1/4	2.80	2.000	2.11	1 11/16-12
304-24-20	1 1/2	1 1/4	3.20	2.000	2.51	2-12
304-20-24	1 1/4	1 1/2	3.50	2.375	2.81	1 11/16-12
304-24-24	1 1/2	1 1/2	3.50	2.375	2.81	2-12
304-24-32	1 1/2	2	3.33	2.812	2.64	2-12

CODE 62 ORFS THREAD						
PART NO.	TUBE O.D.	FLANGE SIZE	A	B	C	THREAD
604-8-8	1/2	1/2	2.58	1.250	2.08	13/16-16
604-12-12	3/4	3/4	2.75	1.625	2.08	1 3/16-12
604-16-12	1	3/4	2.75	1.625	2.06	1 7/16-12
604-12-16	3/4	1	2.80	1.875	2.13	1 3/16-12
604-16-16	1	1	2.80	1.875	2.11	1 7/16-12
604-20-16	1 1/4	1	3.20	1.875	2.51	1 11/16-12
604-16-20	1	1 1/4	3.05	2.125	2.36	1 7/16-12
604-20-20	1 1/4	1 1/4	3.05	2.125	2.36	1 11/16-12
604-24-20	1 1/2	1 1/4	3.30	2.125	2.61	2-12
604-20-24	1 1/4	1 1/2	3.50	2.500	2.81	1 11/16-12
604-24-24	1 1/2	1 1/2	3.50	2.500	2.81	2-12
604-24-32	1 1/2	2	3.58	3.125	2.89	2-12

WELD COUPLINGS

45° JIC Thread

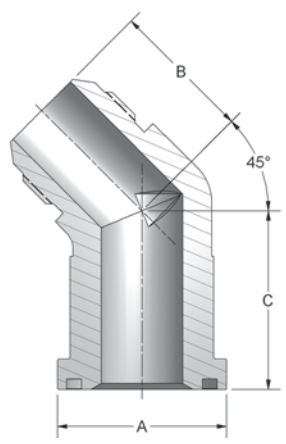

CODE 61 45° JIC THREAD						
PART NO.	TUBE O.D.	FLANGE SIZE	A	B	C	THREAD
340-12-12	3/4	3/4	1.500	1.28	1.58	1 1/16-12
340-16-16	1	1	1.750	1.47	1.85	1 5/16-12
340-20-20	1 1/4	1 1/4	2.000	1.59	2.04	1 5/8-12
340-24-24	1 1/2	1 1/2	2.375	1.78	2.38	1 7/8-12
340-32-32	2	2	2.812	2.22	3.00	2 1/2-12

CODE 62 45° JIC THREAD						
PART NO.	TUBE O.D.	FLANGE SIZE	A	B	C	THREAD
640-12-12	3/4	3/4	1.625	1.28	1.58	1 1/16-12
640-16-16	1	1	1.875	1.47	1.85	1 5/16-12
640-20-20	1 1/4	1 1/4	2.125	1.59	2.04	1 5/8-12
640-24-24	1 1/2	1 1/2	2.500	1.78	2.38	1 7/8-12
640-32-32	2	2	3.13	2.22	3.00	2 1/2-12

FLANGES - CARBON STEEL

45° ORFS Thread

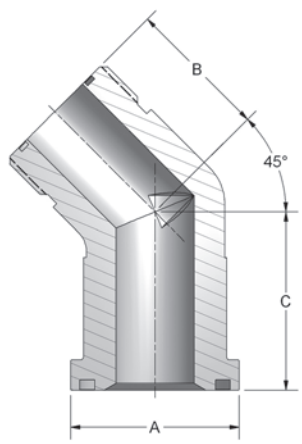

CODE 61 45° ORFS THREAD						
PART NO.	TUBE O.D.	FLANGE SIZE	A	B	C	THREAD
344-12-12	3/4	3/4	1.500	1.28	1.58	1 3/16-12
344-16-16	1	1	1.750	1.47	1.85	1 7/16-12
344-20-20	1 1/4	1 1/4	2.000	1.59	2.04	1 11/16-12
344-24-24	1 1/2	1 1/2	2.375	1.78	2.38	2-12

CODE 62 45° ORFS THREAD						
PART NO.	TUBE O.D.	FLANGE SIZE	A	B	C	THREAD
644-12-12	3/4	3/4	1.625	1.28	1.58	1 3/16-12
644-16-16	1	1	1.875	1.47	1.85	1 7/16-12
644-20-20	1 1/4	1 1/4	2.125	1.59	2.04	1 11/16-12
644-24-24	1 1/2	1 1/2	2.500	1.78	2.38	2-12

FLANGES - STAINLESS STEEL

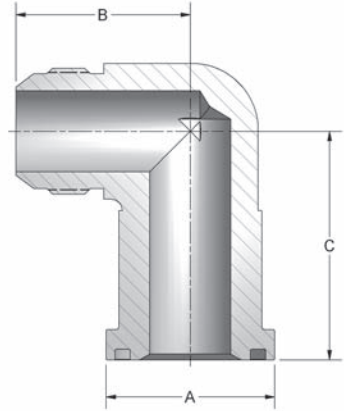

90° JIC Thread



CODE 61 90° JIC THREAD						
PART NO.	TUBE O.D.	FLANGE SIZE	A	B	C	THREAD
390-8-8	1/2	1/2	1.19	1.46	2.13	3/4-16
390-8-12	1/2	3/4	1.500	1.66	2.13	3/4-16
390-12-12	3/4	3/4	1.500	1.66	2.13	1 1/16-12
390-16-12	1	3/4	1.500	1.66	2.13	1 5/16-12
390-12-16	3/4	1	1.750	1.81	2.37	1 1/16-12
390-16-16	1	1	1.750	1.81	2.37	1 5/16-12
390-20-16	1 1/4	1	1.750	1.81	2.37	1 5/8-12
390-12-20	3/4	1 1/4	2.000	2.06	2.62	1 1/16-12
390-16-20	1	1 1/4	2.000	2.06	2.62	1 5/16-12
390-20-20	1 1/4	1 1/4	2.000	2.06	2.62	1 5/8-12
390-24-20	1 1/2	1 1/4	2.000	2.06	2.62	1 7/8-12
390-12-24	3/4	1 1/2	2.375	2.33	3.15	1 1/16-12
390-16-24	1	1 1/2	2.375	2.33	3.15	1 5/16-12
390-20-24	1 1/4	1 1/2	2.375	2.33	3.15	1 5/8-12
390-24-24	1 1/2	1 1/2	2.375	2.33	3.15	1 7/8-12
390-32-24	2	1 1/2	2.375	2.33	3.15	2 1/2-12
390-24-32	1 1/2	2	2.812	3.06	4.25	1 7/8-12
390-32-32	2	2	2.812	3.06	4.25	2 1/2-12
390-32-40	2	2 1/2	3.312	3.06	4.25	2 1/2-12

CODE 62 90° JIC THREAD						
PART NO.	TUBE O.D.	FLANGE SIZE	A	B	C	THREAD
690-8-8	1/2	1/2	1.250	1.66	2.13	3/4-16
690-12-12	3/4	3/4	1.625	1.66	2.13	1 1/16-12
690-16-12	1	3/4	1.625	1.66	2.13	1 5/16-12
690-12-16	3/4	1	1.875	1.81	2.37	1 1/16-12
690-16-16	1	1	1.875	1.81	2.37	1 5/16-12
690-20-16	1 1/4	1	1.875	1.81	2.37	1 5/8-12
690-16-20	1	1 1/4	2.125	2.06	2.76	1 5/16-12
690-20-20	1 1/4	1 1/4	2.125	2.06	2.76	1 5/8-12
690-24-20	1 1/2	1 1/4	2.125	2.19	2.76	1 7/8-12
690-20-24	1 1/4	1 1/2	2.500	2.33	3.15	1 5/8-12
690-24-24	1 1/2	1 1/2	2.500	2.33	3.15	1 7/8-12
690-32-24	2	1 1/2	2.500	3.06	4.25	2 1/2-12
690-24-32	1 1/2	2	3.125	3.06	4.25	1 7/8-12
690-32-32	2	2	3.125	3.06	4.25	2 1/2-12

CODE 61 90° ORFS THREAD						
PART NO.	TUBE O.D.	FLANGE SIZE	A	B	C	THREAD
394-12-12	3/4	3/4	1.500	1.66	2.13	1 3/16-12
394-16-12	1	3/4	1.500	1.66	2.13	1 7/16-12
394-12-16	3/4	1	1.750	1.81	2.37	1 3/16-12
394-16-16	1	1	1.750	1.81	2.37	1 7/16-12
394-20-16	1 1/4	1	1.750	1.81	2.37	1 11/16-12
394-16-20	1	1 1/4	2.000	2.06	2.62	1 7/16-12
394-20-20	1 1/4	1 1/4	2.000	2.06	2.62	1 11/16-12
394-24-20	1 1/2	1 1/4	2.000	2.06	2.62	2-12
394-20-24	1 1/4	1 1/2	2.375	2.33	3.15	1 11/16-12
394-24-24	1 1/2	1 1/2	2.375	2.33	3.15	2-12
394-24-32	1 1/2	2	2.812	3.06	4.25	2-12

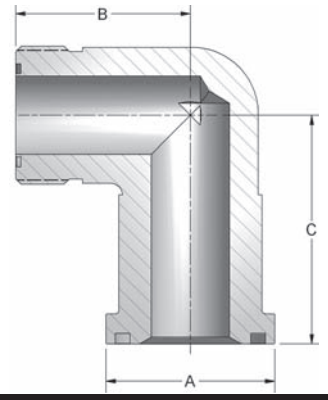

90° ORFS Thread



CODE 62 90° ORFS THREAD						
PART NO.	TUBE O.D.	FLANGE SIZE	A	B	C	THREAD
694-12-8	3/4	1/2	1.250	1.66	2.13	1 3/16-12
694-12-12	3/4	3/4	1.625	1.66	2.13	1 3/16-12
694-16-12	1	3/4	1.625	1.66	2.13	1 7/16-12
694-12-16	3/4	1	1.875	1.81	2.37	1 3/16-12
694-16-16	1	1	1.875	1.81	2.37	1 7/16-12
694-20-16	1 1/4	1	1.875	1.81	2.37	1 11/16-12
694-16-20	1	1 1/4	2.125	2.06	2.76	1 7/16-12
694-20-20	1 1/4	1 1/4	2.125	2.06	2.76	1 11/16-12
694-24-20	1 1/2	1 1/4	2.125	2.06	2.76	2-12
694-20-24	1 1/4	1 1/2	2.500	2.33	3.15	1 11/16-12
694-24-24	1 1/2	1 1/2	2.500	2.33	3.15	2-12
694-24-32	1 1/2	2	3.125	3.06	4.25	2-12

FLOW, NEEDLE & CHECK VALVES

HYDRAULIC BALL VALVES

WELD COUPLINGS

FLANGES - CARBON STEEL

FLANGES - STAINLESS STEEL

FLOW, NEEDLE & CHECK VALVES

HYDRAULIC BALL VALVES

WELD COUPLINGS

FLANGES - CARBON STEEL

FLANGES - STAINLESS STEEL

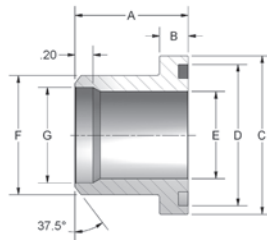

Figure 1

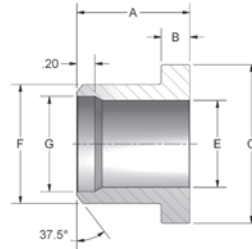

Figure 2

CODE 61 BUTT WELD TO FLANGE HEAD FOR SCHEDULE 40 PIPE										
PART NO. O-RING FIG. 1	PART NO. FLAT FACE FIG. 2	PIPE SIZE	CLAMP SIZE	A	B	C	D	E	F	G
8P-8BWSF-40	8P-8BWSFN-40	.50	.50	1.06	.265	1.188	1.000	.548	.840	.624
12P-12BWSF-40	12P-12BWSFN-40	.75	.75	1.06	.265	1.500	1.250	.744	1.050	.826
16P-16BWSF-40	16P-16BWSFN-40	1.00	1.00	1.25	.315	1.750	1.560	.959	1.315	1.051
20P-20BWSF-40	20P-20BWSFN-40	1.25	1.25	1.44	.315	2.000	1.750	1.280	1.660	1.382
24P-24BWSF-40	24P-24BWSFN-40	1.50	1.50	1.75	.315	2.375	2.115	1.502	1.900	1.612
32P-32BWSF-40	32P-32BWSFN-40	2.00	2.00	2.00	.375	2.812	2.490	1.941	2.375	2.069
40P-40BWSF-40	40P-40BWSFN-40	2.50	2.50	2.31	.375	3.312	2.995	2.325	2.875	2.471
48P-48BWSF-40	48P-48BWSFN-40	3.00	3.00	2.31	.375	4.000	3.615	2.902	3.500	3.070
64P-64BWSF-40	64P-64BWSFN-40	4.00	4.00	1.90	.442	5.000	4.595	3.828	4.500	4.028

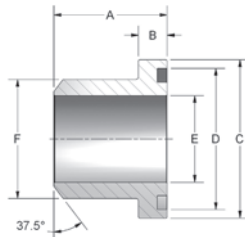

Figure 1

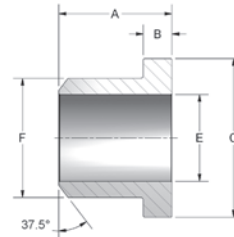

Figure 2

CODE 61 BUTT WELD TO FLANGE HEAD FOR SCHEDULE 80 PIPE									
PART NO. O-RING FIG. 1	PART NO. FLAT FACE FIG. 2	PIPE	CLAMP SIZE	A	B	C	D	E	F
8P-8BWSF-80	8P-8BWSFN-80	.50	.50	1.06	.265	1.188	1.000	.548	.840
12P-12BWSF-80	12P-12BWSFN-80	.75	.75	1.06	.265	1.500	1.250	.744	1.050
16P-16BWSF-80	16P-16BWSFN-80	1.00	1.00	1.25	.315	1.750	1.560	.959	1.315
20P-20BWSF-80	20P-20BWSFN-80	1.25	1.25	1.44	.315	2.000	1.750	1.280	1.660
24P-24BWSF-80	24P-24BWSFN-80	1.50	1.50	1.75	.315	2.375	2.115	1.502	1.900
32P-32BWSF-80	32P-32BWSFN-80	2.00	2.00	2.00	.375	2.812	2.490	1.941	2.375
40P-40BWSF-80	40P-40BWSFN-80	2.50	2.50	2.31	.375	3.312	2.995	2.325	2.875
48P-48BWSF-80	48P-48BWSFN-80	3.00	3.00	2.31	.375	4.000	3.615	2.902	3.500

CODE 61 BUTT WELD TO FLANGE HEAD FOR SCHEDULE 160 PIPE									
PART NO. O-RING FIG. 1	PART NO. FLAT FACE FIG. 2	PIPE SIZE	CLAMP SIZE	A	B	C	D	E	F
8P-8BWSF-160	8P-8BWSFN-160	.50	.50	1.06	.265	1.188	1.000	.464	.840
12P-12BWSF-160	12P-12BWSFN-160	.75	.75	1.06	.265	1.500	1.250	.612	1.050
16P-16BWSF-160	16P-16BWSFN-160	1.00	1.00	1.25	.315	1.750	1.560	.815	1.315
20P-20BWSF-160	20P-20BWSFN-160	1.25	1.25	1.44	.315	2.000	1.750	1.160	1.660
24P-24BWSF-160	24P-24BWSFN-160	1.50	1.50	1.75	.315	2.375	2.115	1.338	1.900
32P-32BWSF-160	32P-32BWSFN-160	2.00	2.00	2.00	.375	2.812	2.490	1.687	2.375
40P-40BWSF-160	40P-40BWSFN-160	2.50	2.50	2.31	.375	3.312	2.995	2.125	2.875
48P-40BWSF-160	48P-40BWSFN-160	3.00	3.00	2.31	.375	4.000	3.615	2.624	3.500

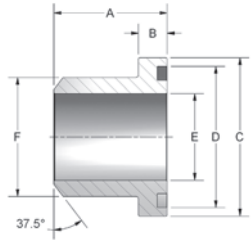

Figure 1

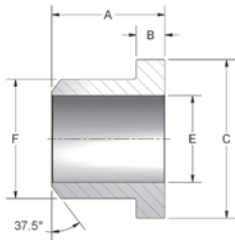

Figure 2

CODE 62 BUTT WELD TO FLANGE HEAD FOR SCHEDULE 80 PIPE									
PART NO. O-RING FIG. 1	PART NO. FLAT FACE FIG. 2	PIPE	CLAMP SIZE	A	B	C	D	E	F
8P-8BWSFX-80	8P-8BWSFXN-80	.50	.50	1.10	.305	1.250	1.000	.548	.840
12P-12BWSFX-80	12P-12BWSFXN-80	.75	.75	1.42	.345	1.625	1.250	.744	1.050
16P-16BWSFX-80	16P-16BWSFXN-80	1.00	1.00	1.61	.375	1.875	1.560	.959	1.315
20P-20BWSFX-80	20P-20BWSFXN-80	1.25	1.25	1.73	.405	2.125	1.750	1.280	1.660
24P-24BWSFX-80	24P-24BWSFXN-80	1.50	1.50	2.17	.495	2.500	2.115	1.502	1.900
32P-32BWSFX-80	32P-32BWSFXN-80	2.00	2.00	2.48	.495	3.125	2.490	1.941	2.375

CODE 62 BUTT WELD TO FLANGE HEAD FOR SCHEDULE 160 PIPE									
PART NO. O-RING FIG. 1	PART NO. FLAT FACE FIG. 2	PIPE SIZE	CLAMP SIZE	A	B	C	D	E	F
8P-8BWSFX-160	8P-8BWSFXN-160	.50	.50	1.10	.305	1.250	1.000	.464	.840
12P-12BWSFX-160	12P-12BWSFXN-160	.75	.75	1.42	.345	1.625	1.250	.612	1.050
16P-16BWSFX-160	16P-16BWSFXN-160	1.00	1.00	1.61	.375	1.875	1.560	.815	1.315
20P-20BWSFX-160	20P-20BWSFXN-160	1.25	1.25	1.73	.405	2.125	1.750	1.160	1.660
24P-24BWSFX-160	24P-24BWSFXN-160	1.50	1.50	2.17	.495	2.500	2.115	1.338	1.900
32P-32BWSFX-160	32P-32BWSFXN-160	2.00	2.00	2.48	.495	3.125	2.490	1.687	2.375

CODE 62 BUTT WELD TO FLANGE HEAD FOR SCHEDULE XXS PIPE									
PART NO. O-RING FIG. 1	PART NO. FLAT FACE FIG. 2	PIPE	CLAMP	A	B	C	D	E	F
8P-8BWSFX-XXS	8P-8BWSFXN-XXS	.50	.50	1.10	.305	1.250	1.000	.252	.840
12P-12BWSFX-XXS	12P-12BWSFXN-XXS	.75	.75	1.42	.345	1.625	1.250	.434	1.050
16P-16BWSFX-XXS	16P-16BWSFXN-XXS	1.00	1.00	1.61	.375	1.875	1.560	.599	1.315
20P-20BWSFX-XXS	20P-20BWSFXN-XXS	1.25	1.25	1.73	.405	2.125	1.750	.896	1.660
24P-24BWSFX-XXS	24P-24BWSFXN-XXS	1.50	1.50	2.17	.495	2.500	2.115	1.100	1.900
32P-32BWSFX-XXS	32P-32BWSFXN-XXS	2.00	2.00	2.48	.495	3.125	2.490	1.503	2.375

FLOW, NEEDLE & CHECK VALVES

HYDRAULIC BALL VALVES

WELD COUPLINGS

FLANGES - CARBON STEEL

FLANGES - STAINLESS STEEL



FLOW, NEEDLE & CHECK VALVES

HYDRAULIC BALL VALVES

WELD COUPLINGS

FLANGES - CARBON STEEL

FLANGES - STAINLESS STEEL

CODE 61 SOCKET WELD TO FLANGE HEAD FOR PIPE											
PART NO.	PIPE SIZE	CLAMP SIZE	A	B	C	D	E	F	G	H	J
8P-8WSF	.50	.50	2.34	.56	.265	1.187	1.000	.500	1.25	.855	.924
12P-12WSF	.75	.75	2.34	.56	.265	1.500	1.250	.750	1.50	1.062	1.234
16P-16WSF	1.00	1.00	2.38	.63	.315	1.750	1.560	1.000	1.75	1.328	1.484
20P-20WSF	1.25	1.25	2.62	.68	.315	2.000	1.750	1.250	2.00	1.672	1.684
24P-24WSF	1.50	1.50	2.88	.76	.315	2.375	2.115	1.500	2.38	1.922	1.964
32P-32WSF	2.00	2.00	3.00	.88	.375	2.812	2.490	2.000	2.81	2.406	2.434
40P-40WSF	2.50	2.50	3.06	1.00	.375	3.312	2.995	2.500	3.31	2.906	2.920
48P-48WSF	3.00	3.00	3.88	1.25	.375	4.000	3.615	2.875	4.00	3.547	3.534

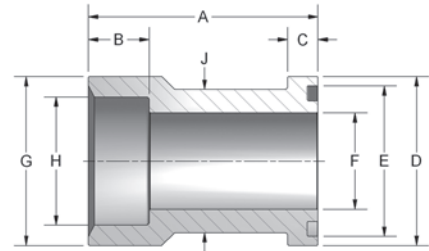

CODE 62 SOCKET WELD TO FLANGE HEAD FOR PIPE											
PART NO.	PIPE	CLAMP SIZE	A	B	C	D	E	F	G	H	J
W53-12-12	.75	.75	2.75	.630	.345	1.625	1.250	.750	1.750	1.062	1.234
W53-16-16	1.00	1.00	3.06	.630	.375	1.875	1.560	1.000	2.000	1.328	1.484
W53-20-20	1.25	1.25	3.31	.690	.405	2.125	1.750	1.125	2.312	1.672	1.704
W53-24-24	1.50	1.50	3.93	.750	.495	2.500	2.115	1.375	2.750	1.922	1.984
W53-32-32	2.00	2.00	4.06	.880	.495	3.125	2.490	1.875	3.125	2.406	2.604



CODE 61 NPTF THREAD TO FLANGE HEAD										
PART NO.	PIPE SIZE	CLAMP SIZE	A	B	C	D	E	F	G	H
12F-12FO	.75	.75	2.47	.265	1.500	1.250	.75	1.50	.75	1.234
16F-16FO	1.00	1.00	2.66	.315	1.750	1.560	1.00	1.75	1.00	1.484
20F-20FO	1.25	1.25	2.84	.315	2.000	1.750	1.25	2.00	1.25	1.684
24F-24FO	1.50	1.50	3.00	.315	2.375	2.115	1.50	2.38	1.50	1.964
32F-32FO	2.00	2.00	3.00	.375	2.812	2.490	2.00	2.81	2.00	2.434

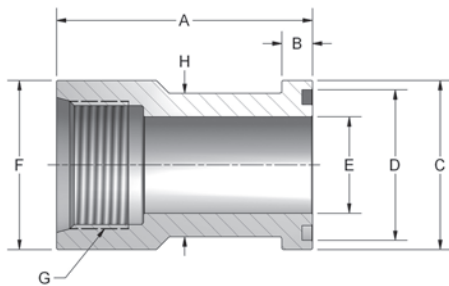

CODE 61 SAE THREAD TO FLANGE HEAD										
PART NO.	TUBE SIZE	CLAMP SIZE	A	B	C	D	E	F	G	H
12S-12FO	.75	.75	2.47	.265	1.500	1.250	.75	1.50	1 1/16-12	1.234
16S-16FO	1.00	1.00	2.66	.315	1.750	1.560	1.00	1.75	1 5/16-12	1.484
20S-20FO	1.25	1.25	2.84	.315	2.000	1.750	1.25	2.00	1 5/8-12	1.684
24S-24FO	1.50	1.50	3.00	.315	2.375	2.115	1.50	2.38	1 7/8-12	1.964
32S-32FO	2.00	2.00	3.00	.375	2.812	2.490	2.00	2.81	2 1/2-12	2.434

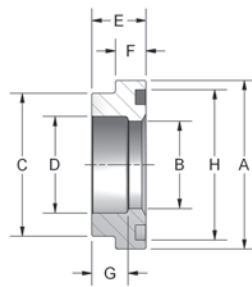

Figure 1

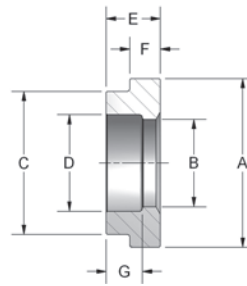

Figure 2



*For sizes not listed, please consult factory.

CODE 61 TUBE FLANGE HEAD FITTING											
PART NO. O-RING FIG. 1	PART NO. FLAT FACE FIG. 2	TUBE SIZE	FLANGE SIZE	A	B	C	D	E	F	G	H
8T-8SF	8T-8SFN	.50	.50	1.188	.406	.924	.502	.50	.265	.312	1.000
10T-8SF	10T-8SFN	.63	.50	1.188	.500	.924	.627	.50	.265	.312	1.000
12T-12SF	12T-12SFN	.75	.75	1.500	.656	1.234	.752	.56	.265	.375	1.250
16T-12SF	16T-12SFN	1.00	.75	1.500	.750	1.234	1.002	.56	.265	.375	1.250
16T-16SF	16T-16SFN	1.00	1.00	1.750	.906	1.484	1.002	.56	.315	.375	1.560
20T-16SF	20T-16SFN	1.25	1.00	1.750	1.000	1.484	1.252	.56	.315	.375	1.560
20T-20SF	20T-20SFN	1.25	1.25	2.000	1.125	1.684	1.252	.56	.315	.375	1.750
24T-20SF	24T-20SFN	1.50	1.25	2.000	1.250	1.684	1.502	.56	.315	.375	1.750
24T-24SF	24T-24SFN	1.50	1.50	2.375	1.375	1.964	1.502	.62	.315	.438	2.115
28T-24SF	28T-24SFN	1.75	1.50	2.375	1.500	1.964	1.752	.62	.315	.438	2.115
32T-32SF	32T-32SFN	2.00	2.00	2.812	1.875	2.434	2.002	.62	.375	.500	2.490
36T-32SF	36T-32SFN	2.25	2.00	2.812	2.000	2.434	2.252	.62	.375	.500	2.490
40T-40SF	40T-40SFN	2.50	2.50	3.312	2.375	2.904	2.502	.68	.375	.562	2.995
44T-40SF	44T-40SFN	2.75	2.50	3.312	2.500	2.904	2.752	.68	.375	.500	2.995
48T-48SF	48T-48SFN	3.00	3.00	4.000	2.875	3.534	3.002	.75	.375	.562	3.615
56T-56SF	56T-56SFN	3.50	3.50	4.500	3.380	3.980	3.502	.88	.440	.750	4.100
64T-64SF	64T-64SFN	4.00	4.00	5.000	3.880	4.480	4.040	1.00	.440	.810	4.600
80T-80SF	80T-80SFN	5.00	5.00	6.000	4.880	5.480	5.002	1.13	.440	.940	5.600

CODE 62 TUBE FLANGE HEAD FITTING											
PART NO. O-RING FIG. 1	PART NO. FLAT FACE FIG. 2	TUBE SIZE	FLANGE SIZE	A	B	C	D	E	F	G	H
12T-12SFX	12T-12SFXN	.75	.75	1.625	.656	1.234	.752	.69	.345	.500	1.250
16T-12SFX	16T-12SFXN	1.00	.75	1.625	.750	1.234	1.002	.69	.345	.500	1.250
16T-16SFX	16T-16SFXN	1.00	1.00	1.875	.810	1.484	1.002	.81	.375	.625	1.560
20T-16SFX	20T-16SFXN	1.25	1.00	1.875	1.000	1.484	1.252	.81	.375	.625	1.560
20T-20SFX	20T-20SFXN	1.25	1.25	2.125	1.010	1.704	1.252	1.00	.405	.812	1.750
24T-20SFX	24T-20SFXN	1.50	1.25	2.125	1.250	1.704	1.502	1.00	.405	.812	1.750
24T-24SFX	24T-24SFXN	1.50	1.50	2.500	1.250	1.984	1.502	1.19	.495	1.000	2.115
28T-24SFX	28T-24SFXN	1.75	1.50	2.500	1.500	1.984	1.757	1.19	.495	1.000	2.115
32T-32SFX	32T-32SFXN	2.00	2.00	3.125	1.750	2.604	2.002	1.50	.495	1.375	2.490
36T-32SFX	36T-32SFXN	2.25	2.00	3.125	2.000	2.604	2.252	1.50	.495	1.312	2.490

FLOW, NEEDLE & CHECK VALVES

HYDRAULIC BALL VALVES

WELD COUPLINGS

FLANGES - CARBON STEEL

FLANGES - STAINLESS STEEL



AISI 1020 Carbon Steel Material
 Natural Finish
 O-Ring groove per SAE J1453, Style "B" for improved O-ring retention
 O-Ring not included

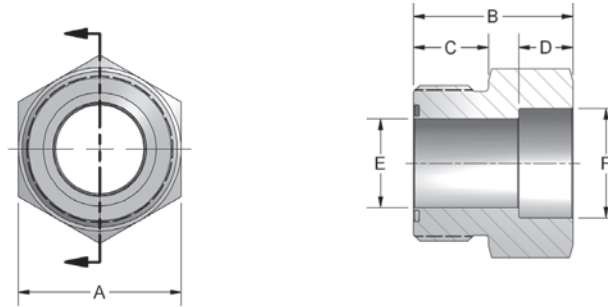

BRAZE-ON TUBE FITTINGS								
PART NO.	TUBE SIZE	ORFS THREAD SIZE	A	B	C	D	E	F
1453-04-04	1/4"	9/16"-18	.625	.780	.386	.250	.172	.252
1453-05-04	5/16"	9/16"-18	.625	.780	.386	.250	.172	.315
1453-06-04	3/8"	9/16"-18	.750	.780	.386	.250	.172	.377
1453-06-06	3/8"	11/16"-16	.750	.830	.441	.250	.264	.377
1453-08-06	1/2"	11/16"-16	.875	.950	.441	.375	.264	.502
1453-08-08	1/2"	13/16"-16	.875	1.010	.504	.375	.378	.502
1453-10-08	5/8"	13/16"-16	.937	1.060	.504	.375	.378	.627
1453-12-08	3/4"	13/16"-16	1.125	1.040	.504	.375	.378	.752
1453-14-08	7/8"	13/16"-16	1.250	1.09	.504	.375	.378	.877
1453-10-10	5/8"	1"-14	1.062	1.120	.610	.375	.484	.627
1453-12-10	3/4"	1"-14	1.125	1.150	.610	.375	.484	.752
1453-16-10	1"	1"-14	1.375	1.340	.610	.500	.484	1.002
1453-12-12	3/4"	1-3/16"-12	1.250	1.210	.670	.375	.609	.752
1453-14-12	7/8"	1-3/16"-12	1.250	1.210	.670	.375	.609	.877
1453-16-12	1"	1-3/16"-12	1.500	1.450	.670	.500	.609	1.002
1453-16-16	1"	1-7/16"-12	1.500	1.470	.689	.500	.811	1.002
1453-20-16	1-1/4"	1-7/16"-12	1.750	1.470	.689	.500	.811	1.252
1453-20-20	1-1/4"	1-11/16"-12	1.750	1.470	.689	.500	1.024	1.252
1453-24-20	1-1/2"	1-11/16"-12	2.000	1.470	.689	.500	1.024	1.502
1453-24-24	1-1/2"	2"-12	2.125	1.470	.689	.500	1.260	1.502
1453-28-24	1-3/4"	2"-12	2.125	1.470	.689	.531	1.260	1.752

AISI 1020 Carbon Steel Material
 Natural Finish
 37° Male JIC per SAE J514

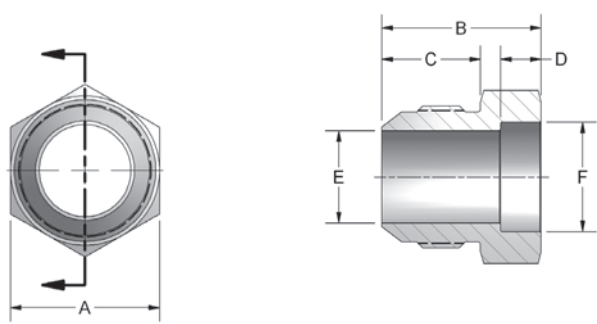

JIC BRAZE-ON									
PART NO.	TUBE SIZE	JIC THREAD SIZE	A	B	C	D	E	F	
51437-6-6	3/8"	9/16"-18	.625	.906	.556	.250	.297	.377	
51437-8-8	1/2"	3/4"-16	.813	1.063	.657	.250	.394	.502	
51437-12-12	3/4"	1 1/16"-12	1.125	1.344	.864	.312	.611	.752	

FLOW, NEEDLE & CHECK VALVES

HYDRAULIC BALL VALVES

WELD COUPLINGS

FLANGES - CARBON STEEL

FLANGES - STAINLESS STEEL



Fits Caterpillar Flange Head ends only

* CAT-Style Flange Plugs also available.
Consult factory for details.

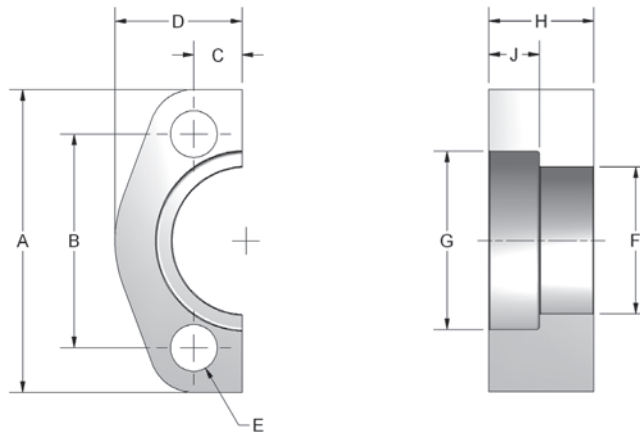

PTX SERIES SPLIT FLANGES												
PART NO.	**KIT PART NO.	FLANGE SIZE	A	B	C	D	E	F	G	H	J	MOUNTING HARDWARE
												HHCS
12PTX-2	12PTXO	.75	2.950	2.000	.446	1.210	.406	1.270	1.632	1.102	.530	3/8-16X1.75
16PTX-2	16PTXO	1.00	3.190	2.250	.507	1.335	.469	1.550	1.884	1.102	.530	7/16-14X1.75
20PTX-2	20PTXO	1.25	3.750	2.625	.585	1.490	.531	1.705	2.134	1.102	.530	1/2-13X2.00
24PTX-2	24PTXO	1.50	4.440	3.125	.679	1.335	.656	2.080	2.509	1.258	.530	5/8-11X2.50
32PTX-2	32PTXO	2.00	5.240	3.812	.834	2.205	.827	2.640	3.130	1.457	.530	3/4-10X2.75

**When ordering this part # you will receive:(2) split flange halves, (4) hex head bolts and lockwashers. NO O-RING INCLUDED.

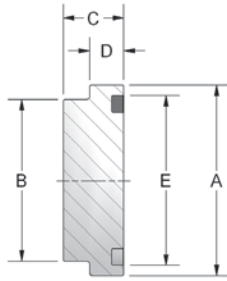

Figure 1

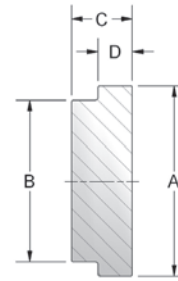

Figure 2

CODE 61 FLANGE PLUG							
PART NO. O-RING FIG. 1	PART NO. FLAT FACE FIG. 2	FLANGE SIZE	A	B	C	D	E
8FOP	8FP	.50	1.188	.924	.50	.265	1.000
12FOP	12FP	.75	1.500	1.234	.56	.265	1.250
16FOP	16FP	1.00	1.750	1.484	.56	.315	1.560
20FOP	20FP	1.25	2.000	1.684	.56	.315	1.750
24FOP	24FP	1.50	2.375	1.964	.62	.315	2.115
32FOP	32FP	2.00	2.810	2.434	.62	.375	2.490
40FOP	40FP	2.50	3.312	2.904	.68	.375	2.995
48FOP	48FP	3.00	4.000	3.534	.75	.375	3.615

CODE 62 FLANGE PLUG							
PART NO. O-RING FIG. 1	PART NO. FLAT FACE FIG. 2	FLANGE SIZE	A	B	C	D	E
12FOPX	12FPX	.75	1.625	1.234	.690	.345	1.250
16FOPX	16FPX	1.00	1.875	1.484	.810	.375	1.560
20FOPX	20FPX	1.25	2.125	1.704	1.000	.405	1.750
24FOPX	24FPX	1.50	2.500	1.984	1.190	.495	2.115
32FOPX	32FPX	2.00	3.125	2.604	1.500	.495	2.490

FLOW, NEEDLE & CHECK VALVES

HYDRAULIC BALL VALVES

WELD COUPLINGS

FLANGES - CARBON STEEL

FLANGES - STAINLESS STEEL

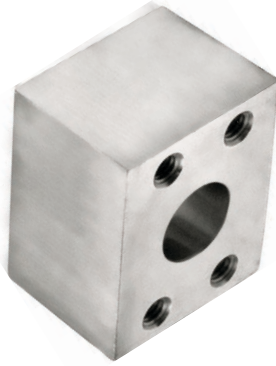

Used to connect two o-ring flanges

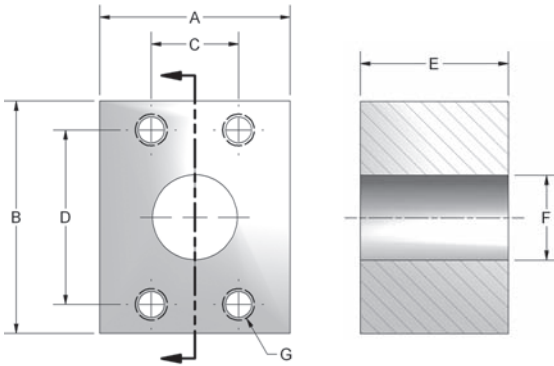

CODE 61 CONNECTOR BLOCK								
PART NO.	PAD SIZE	A	B	C	D	E	F	G UNC-2B
ACB 8-8	.50	2.00	2.12	.688	1.500	1.75	.502	5/16-18
ACB 12-12	.75	2.00	2.62	.875	1.875	1.75	.752	3/8-16
ACB 16-16	1.00	2.25	2.75	1.031	2.062	1.75	1.002	3/8-16
ACB 20-20	1.25	3.00	3.19	1.188	2.312	2.125	1.252	7/16-14
ACB 24-24	1.50	3.50	3.75	1.406	2.750	2.125	1.502	1/2-13
ACB 32-32	2.00	3.88	4.00	1.688	3.062	2.125	1.942	1/2-13
ACB 40-40	2.50	4.38	4.50	2.000	3.500	2.375	2.442	1/2-13

CODE 62 CONNECTOR BLOCK								
PART NO.	PAD SIZE	A	B	C	D	E	F	G UNC-2B
ACBX 8-8	.50	2.00	2.22	.718	1.594	1.75	.502	5/16-18
ACBX 12-12	.75	2.50	2.81	.937	2.000	2.00	.752	3/8-16
ACBX 16-16	1.00	2.75	3.19	1.093	2.250	2.00	1.002	7/16-14
ACBX 20-20	1.25	3.00	3.75	1.250	2.625	2.00	1.252	1/2-13
ACBX 24-24	1.50	3.88	4.50	1.437	3.125	2.50	1.502	5/8-11
ACBX 32-32	2.00	4.50	5.25	1.750	3.812	2.95	1.942	3/4-10

CODE 61 CONNECTOR PLATE							
PART NO.	PAD SIZE	A	B	C	D	E	F
8 CP	.50	1.81	2.12	.688	1.500	.50	.344
12 CP	.75	2.06	2.56	.875	1.875	.75	.406
16 CP	1.00	2.31	2.75	1.031	2.062	1.00	.406
20 CP	1.25	2.88	3.12	1.188	2.312	1.25	.469
24 CP	1.50	3.25	3.69	1.406	2.750	1.50	.531
32 CP	2.00	3.81	4.00	1.688	3.062	2.00	.531
40 CP	2.50	4.12	4.44	2.000	3.500	2.50	.531
48 CP	3.00	5.16	5.31	2.438	4.188	3.00	.656

CODE 62 CONNECTOR PLATE							
PART NO.	PAD SIZE	A	B	C	D	E	F
12 CPX	.75	2.38	2.81	.937	2.000	.750	.406
16 CPX	1.00	2.75	3.19	1.093	2.250	1.000	.469
20 CPX	1.25	3.06	3.75	1.250	2.625	1.250	.531
24 CPX	1.50	3.75	4.44	1.437	3.125	1.500	.656
32 CPX	2.00	4.50	5.25	1.750	3.812	2.000	.781

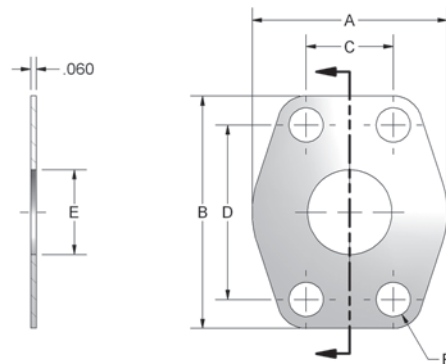

Used to connect two flat faced flanges

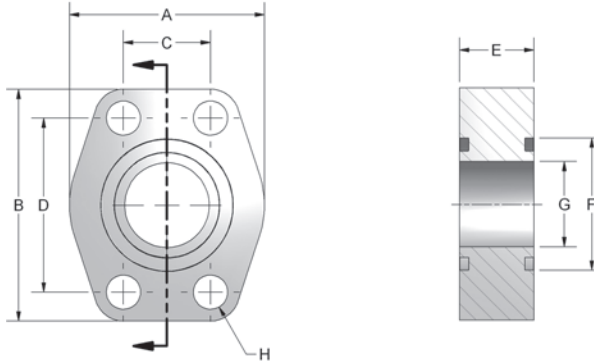

CODE 61 DOUBLE O-RING SPACER									
PART NO.	PAD	A	B	C	D	E	F	G	H
ADOS-8-8	.50	1.813	2.125	.688	1.50	.750	1.000	.502	.344
ADOS-12-12	.75	2.063	2.563	.875	1.875	.750	1.250	.752	.406
ADOS-16-16	1.00	2.313	2.750	1.031	2.063	.880	1.560	1.002	.406
ADOS-20-20	1.25	2.875	3.125	1.188	2.313	.940	1.750	1.252	.469
ADOS-24-24	1.50	3.250	3.688	1.406	2.750	1.190	2.115	1.502	.531
ADOS-32-32	2.00	3.813	4.000	1.688	3.063	1.44	2.490	2.002	.531
ADOS-40-40	2.50	4.281	4.500	2.000	3.500	1.815	2.995	2.502	.531
ADOS-48-48	3.00	5.156	5.313	2.438	4.188	2.190	3.615	3.002	.656
ADOS-56-56	3.50	5.500	6.000	2.750	4.750	1.440	4.095	3.502	.656
ADOS-64-64	4.00	6.00	6.38	3.062	5.125	1.44	4.595	4.002	.656

CODE 62 DOUBLE O-RING SPACER									
PART NO. O-RING	PAD	A	B	C	D	E	F	G	H
ADOSX-8-8	.500	1.94	2.30	.718	1.594	1.25	1.000	.502	.344
ADOSX-12-12	.750	2.50	2.95	.937	2.000	1.250	1.250	.752	.406
ADOSX-16-16	1.00	2.75	3.19	1.093	2.250	1.500	1.560	1.002	.492
ADOSX-20-20	1.25	3.06	3.75	1.250	2.625	1.430	1.750	1.252	.531
ADOSX-24-24	1.50	3.75	4.44	1.437	3.125	1.815	2.115	1.502	.656
ADOSX-32-32	2.00	4.50	5.25	1.750	3.812	1.815	2.490	2.002	.781
ADOSX-40-40	2.50	5.87	6.87	2.312	4.875	1.930	2.995	2.502	.906
ADOSX-48-48	3.00	7.00	8.50	2.812	6.000	2.69	3.615	3.002	1.156

FLOW, NEEDLE & CHECK VALVES

HYDRAULIC BALL VALVES

WELD COUPLINGS

FLANGES - CARBON STEEL

FLANGES - STAINLESS STEEL

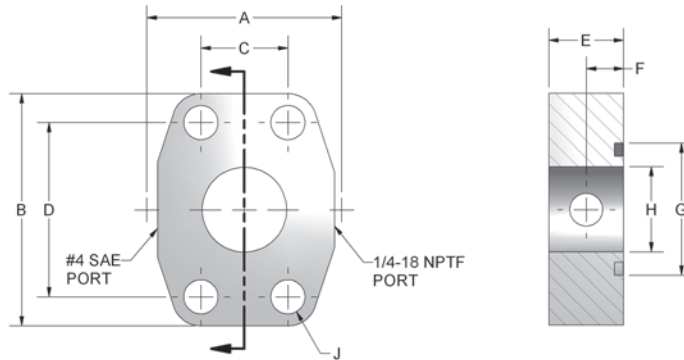
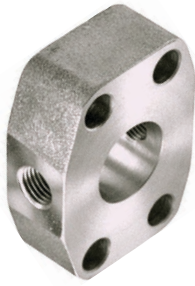

Includes O-ring and plugs for both ports

CODE 61 GAGE PORT O-RING SPACER										
PART NO.	PAD	A	B	C	D	E	F	G	H	J
AS-8-GP	.50	1.82	2.16	.688	1.500	1.25	.62	1.000	.502	.344
AS-12-GP	.75	2.06	2.69	.875	1.875	1.25	.62	1.250	.752	.406
AS-16-GP	1.00	2.31	2.75	1.031	2.062	.88	.44	1.560	1.002	.406
AS-20-GP	1.25	2.87	3.12	1.188	2.312	.94	.47	1.750	1.252	.469
AS-24-GP	1.50	3.25	3.68	1.406	2.750	1.19	.59	2.115	1.502	.531
AS-32-GP	2.00	3.81	4.00	1.688	3.062	1.38	.69	2.490	2.002	.531
AS-40-GP	2.50	4.28	4.50	2.000	3.500	1.75	.88	2.995	2.502	.531
AS-48-GP	3.00	5.15	5.31	2.438	4.188	2.12	1.06	3.615	3.002	.656
AS-56-GP	3.50	5.50	6.00	2.750	4.750	1.44	.720	4.095	3.502	.656
AS-64-GP	4.00	6.00	6.38	3.062	5.125	1.50	.750	4.595	4.002	.656

CODE 62 GAGE PORT O-RING SPACER										
PART NO.	PAD	A	B	C	D	E	F	G	H	J
ASX-8-GP	.50	1.94	2.30	.718	1.594	1.25	.62	1.000	.502	.344
ASX-12-GP	.75	2.50	2.95	.937	2.000	1.25	.62	1.250	.752	.406
ASX-16-GP	1.00	2.75	3.19	1.093	2.250	1.50	.75	1.560	1.002	.492
ASX-20-GP	1.25	3.06	3.75	1.250	2.625	1.50	.75	1.750	1.252	.531
ASX-24-GP	1.50	3.75	4.44	1.437	3.125	1.75	.88	2.115	1.502	.656
ASX-32-GP	2.00	4.50	5.25	1.750	3.812	1.75	.88	2.490	2.002	.781
ASX-40-GP	2.50	5.87	6.87	2.312	4.875	2.06	1.03	2.995	2.502	.906
ASX-48-GP	3.00	7.00	8.50	2.812	6.000	2.62	1.31	3.615	3.002	1.156

CODE 61 ORIFICE PLATE									
PART NO.	PAD SIZE	A	B	C	D	E	F	G	H
AOP-___-0861	.50	1.81	2.12	.688	1.500	.33	1.000	.344	CUSTOMER SPECIFIED
AOP-___-1261	.75	2.06	2.56	.875	1.875	.33	1.250	.413	
AOP-___-1661	1.00	2.31	2.75	1.031	2.063	.33	1.560	.413	
AOP-___-2061	1.25	2.88	3.12	1.188	2.313	.33	1.750	.469	
AOP-___-2461	1.50	3.25	3.69	1.406	2.750	.33	2.115	.531	
AOP-___-3261	2.00	3.81	4.00	1.688	3.063	.33	2.490	.531	
AOP-___-4061	2.50	4.28	4.50	2.000	3.500	.33	2.995	.531	
AOP-___-4861	3.00	5.16	5.31	2.438	4.188	.33	3.615	.656	
AOP-___-5661	3.50	5.50	6.00	2.750	4.750	.33	4.095	.656	
AOP-___-6461	4.00	6.00	6.38	3.062	5.125	.33	4.595	.656	

CODE 62 ORIFICE PLATE									
PART NO.	PAD SIZE	A	B	C	D	E	F	G	H DIA.
AOPX-___-0862	.50	1.94	2.19	.718	1.594	.33	1.000	.354	CUSTOMER SPECIFIED
AOPX-___-1262	.75	2.50	2.81	.937	2.000	.33	1.250	.433	
AOPX-___-1662	1.00	2.75	3.19	1.093	2.250	.33	1.560	.531	
AOPX-___-2062	1.25	3.06	3.75	1.250	2.625	.33	1.750	.610	
AOPX-___-2462	1.50	3.75	4.44	1.437	3.125	.33	2.115	.689	
AOPX-___-3262	2.00	4.50	5.25	1.750	3.812	.33	2.490	.866	

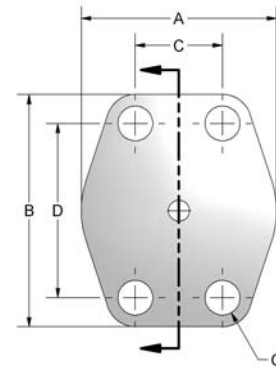
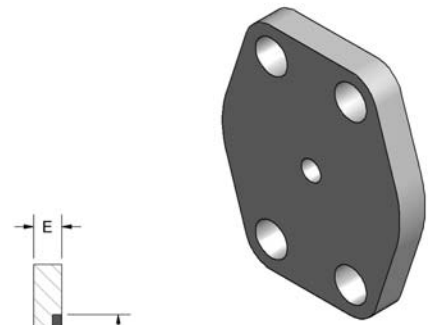

Ordering Information

AOP - 0.500 - 32 61

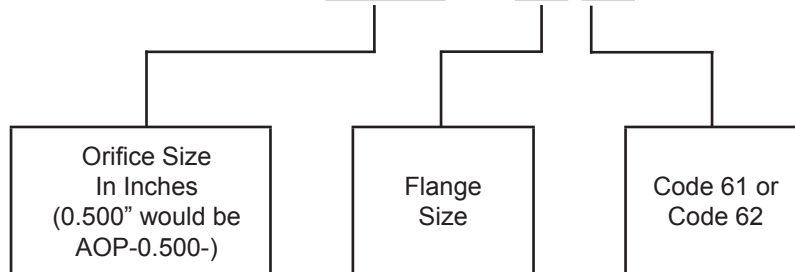

FLOW, NEEDLE & CHECK VALVES

HYDRAULIC BALL VALVES

WELD COUPLINGS

FLANGES - CARBON STEEL

FLANGES - STAINLESS STEEL

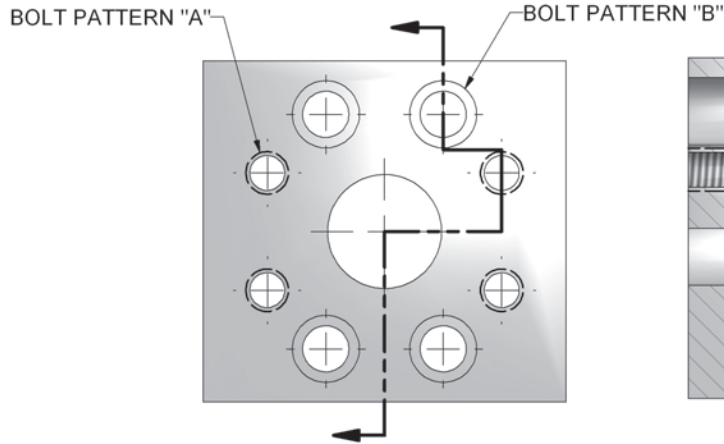

Outer envelope shape may vary due to size configuration.
 Mounting kit available on o-ring grooved flanges by simply adding suffix letter 'U' to part number.

Ordering Information

AFA - 1261 - 3262

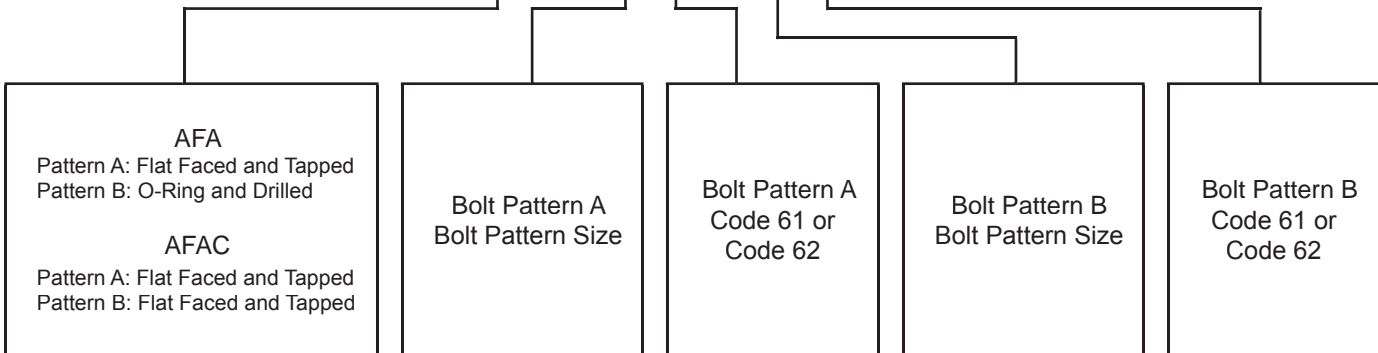

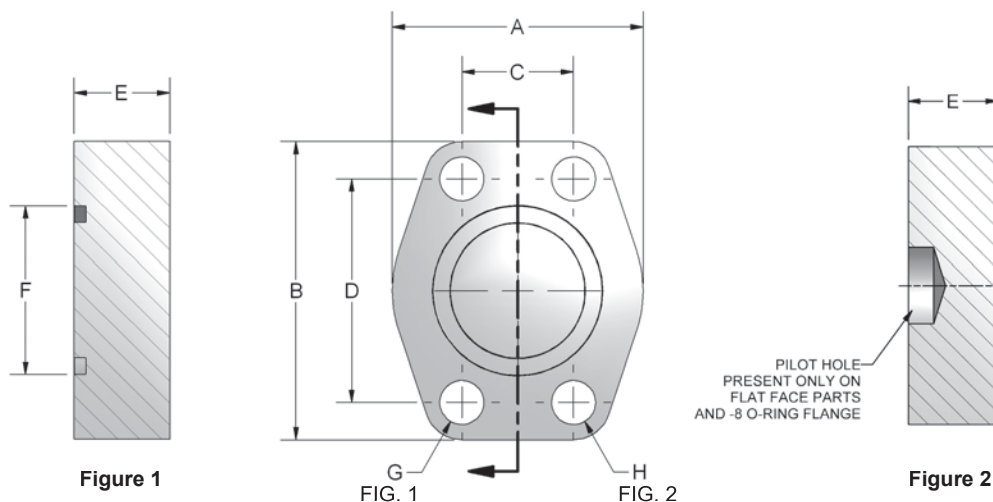

CODE 61 BLANKING												
PART NO. O-RING FIG. 1	PART NO. FLAT FACE FIG. 2	PAD	A	B	C	D	E	F	G	H UNC-2B	MOUNTING HARDWARE	
											O-RING	SHCS
W36-8-8	W37-8-8	.50	1.813	2.125	.688	1.50	.75	1.000	.344	5/16-18	210	5/16-18X1.50
W36-12-12	W37-12-12	.75	2.063	2.563	.875	1.875	.75	1.250	.406	3/8-16	214	3/8-16X1.50
W36-16-16	W37-16-16	1.00	2.313	2.750	1.031	2.063	.88	1.560	.406	3/8-16	219	3/8-16X1.75
W36-20-20	W37-20-20	1.25	2.875	3.125	1.188	2.313	.94	1.750	.469	7/16-14	222	7/16-14X1.75
W36-24-24	W37-24-24	1.50	3.250	3.688	1.406	2.750	1.19	2.115	.531	1/2-13	225	1/2-13X2.25
W36-32-32	W37-32-32	2.00	3.813	4.000	1.688	3.063	1.44	2.490	.531	1/2-13	228	1/2-13X2.50
W36-40-40	W37-40-40	2.50	4.281	4.500	2.000	3.500	1.82	2.995	.531	1/2-13	232	1/2-13X2.75
W36-48-48	W37-48-48	3.00	5.156	5.313	2.438	4.188	2.19	3.615	.656	5/8-11	237	5/8-11X3.50
W36-56-56	W37-56-56	3.50	5.500	6.000	2.750	4.750	1.44	4.095	.656	5/8-11	241	5/8-11X2.75
W36-64-64	W37-64-64	4.00	6.00	6.38	3.062	5.125	1.44	4.595	.656	5/8-11	245	5/8-11X2.75
W36-80-80	W37-80-80	5.00	7.12	7.25	3.625	6.000	1.75	5.595	.656	5/8-11	253	5/8-11X3.00

CODE 62 BLANKING												
PART NO. O-RING FIG. 1	PART NO. FLAT FACE FIG. 2	PAD	A	B	C	D	E	F	G	H UNC-2B	MOUNTING HARDWARE	
											O-RING	SHCS
W38-8-8	W39-8-8	.500	1.94	2.30	.718	1.594	1.25	1.000	.344	5/16-18	210	5/16-18X2.00
W38-12-12	W39-12-12	.750	2.50	2.95	.937	2.000	1.25	1.250	.406	3/8-16	214	3/8-16X2.00
W38-16-16	W39-16-16	1.00	2.75	3.19	1.093	2.250	1.50	1.560	.492	7/16-14	219	7/16-14X2.50
W38-20-20	W39-20-20	1.25	3.06	3.75	1.250	2.625	1.43	1.750	.531	1/2-13	222	1/2-13X2.50
W38-24-24	W39-24-24	1.50	3.75	4.44	1.437	3.125	1.82	2.115	.656	5/8-11	225	5/8-11X3.00
W38-32-32	W39-32-32	2.00	4.50	5.25	1.750	3.812	1.82	2.490	.781	3/4-10	228	3/4-10X3.00
W38-40-40	W39-40-40	2.50	5.87	6.87	2.312	4.875	1.93	2.995	.906	7/8-9	232	7/8-9X3.50
W38-48-48	W39-48-48	3.00	7.00	8.50	2.812	6.000	2.69	3.615	1.190	1 1/8-7	237	1 1/8-7X4.50

Mounting kit available on o-ring grooved flanges by simply adding suffix letter 'U' to part number.

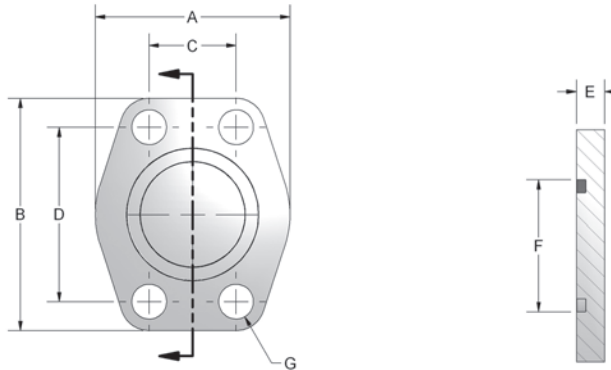

Anchor Fluid Power has developed a low cost solution to leaky, gasketless port covers. Forged steel shipping plates are 0.33” thick, silver trivalent plated for resistance to oxidation, and incorporate an o-ring groove on one side for “Zero Pressure” applications. The opposite side has a machined flat-face for capping off hose ends.

CODE 61 SHIPPING PLATE											
PART	**KIT PART	PAD SIZE	A	B	C	D	E	F	G	MOUNTING HARDWARE	
										O-RING	HHCS
SP-8	SP-8U	.50	1.81	2.12	.688	1.500	.33	1.000	.344	210	5/16-18X.75
SP-12	SP-12U	.75	2.06	2.56	.875	1.875	.33	1.250	.413	214	3/8-16X.75
SP-16	SP-16U	1.00	2.31	2.75	1.031	2.063	.33	1.560	.413	219	3/8-16X.75
SP-20	SP-20U	1.25	2.88	3.12	1.188	2.313	.33	1.750	.469	222	7/16-14X.75
SP-24	SP-24U	1.50	3.25	3.69	1.406	2.750	.33	2.115	.531	225	1/2-13X.75
SP-32	SP-32U	2.00	3.81	4.00	1.688	3.063	.33	2.490	.531	228	1/2-13X.75
SP-40	SP-40U	2.50	4.28	4.50	2.000	3.500	.33	2.995	.531	232	1/2-13X.75
SP-48	SP-48U	3.00	5.16	5.31	2.438	4.188	.33	3.615	.656	237	5/8-11X1.00
SP-56	SP-56U	3.50	5.50	6.00	2.750	4.750	.33	4.095	.656	241	5/8-11X1.00
SP-64	SP-64U	4.00	6.00	6.38	3.062	5.125	.33	4.595	.656	245	5/8-11X1.00

CODE 62 SHIPPING PLATE											
PART NO.	**KIT PART	PAD SIZE	A	B	C	D	E	F	G	MOUNTING HARDWARE	
										O-RING	HHCS
SPX-8	SPX-8U	.50	1.94	2.19	.718	1.594	.33	1.000	.354	210	5/16-18X.75
SPX-12	SPX-12U	.75	2.50	2.81	.937	2.000	.33	1.250	.433	214	3/8-16X.75
SPX-16	SPX-16U	1.00	2.75	3.19	1.093	2.250	.33	1.560	.531	219	7/16-14X.75
SPX-20	SPX-20U	1.25	3.06	3.75	1.250	2.625	.33	1.750	.610	222	1/2-13X.75
SPX-24	SPX-24U	1.50	3.75	4.44	1.437	3.125	.33	2.115	.689	225	5/8-11X1.00
SPX-32	SPX-32U	2.00	4.50	5.25	1.750	3.812	.33	2.490	.866	228	3/4-10X1.00

Applications Include: Cylinder Port Covers, Pump Port Covers, Stub-Out Header Line Covers, Maintenance Work and Great for Painting Protection

**When ordering this part # you will receive:(1) shipping plate, (4) hex head bolts, and (1) Buna N O-Ring

NOT FOR USE ON DYNAMIC OR PRESSURIZED APPLICATIONS

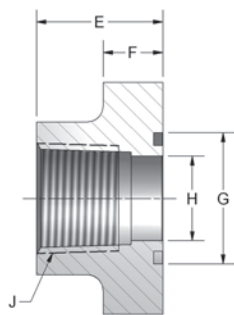
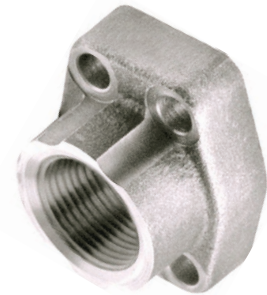

Figure 1

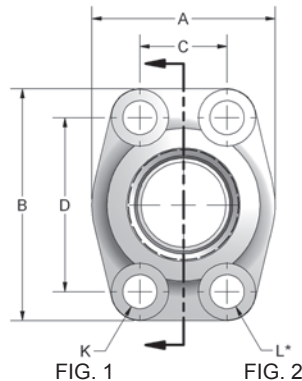

FIG. 1 FIG. 2

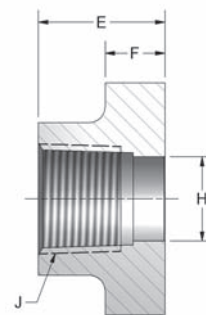

Figure 2

*No Spotface

CODE 61 NPTF THREAD

PART NO. O-RING FIG. 1	PART NO. FLAT FACE FIG. 2	PORT SIZE	PAD SIZE	A	B	C	D	E	F	G	H	J	K	L UNC-2B	MOUNTING HARDWARE	
															O-RING	SHCS
W43-8-8	W104-8-8	.50	.50	1.81	2.13	.688	1.500	1.42	.63	1.000	.502	1/2-14	.344	5/16-18	210	5/16-18X1.25
W43-12-12	W104-12-12	.75	.75	1.97	2.56	.875	1.875	1.42	.71	1.250	.752	3/4-14	.406	3/8-16	214	3/8-16X1.50
W43-16-16	W104-16-16	1.00	1.00	2.17	2.75	1.031	2.062	1.50	.71	1.560	1.002	1-11.5	.406	3/8-16	219	3/8-16X1.50
W43-20-20	W104-20-20	1.25	1.25	2.68	3.12	1.188	2.312	1.61	.83	1.750	1.252	1 1/4-11.5	.469	7/16-14	222	7/16-14X1.75
W43-24-24	W104-24-24	1.50	1.50	3.07	3.66	1.406	2.750	1.77	.98	2.115	1.502	1 1/2-11.5	.531	1/2-13	225	1/2-13X1.75
W43-32-32	W104-32-32	2.00	2.00	3.54	4.00	1.688	3.062	1.77	.98	2.490	2.002	2-11.5	.531	1/2-13	228	1/2-13X1.75
W43-40-40	W104-40-40	2.50	2.50	4.09	4.49	2.000	3.500	1.97	.98	2.995	2.502	2 1/2-8	.531	1/2-13	232	1/2-13X1.75
W43-48-48	W104-48-48	3.00	3.00	4.88	5.28	2.438	4.188	1.97	1.06	3.615	3.002	3-8	.656	5/8-11	237	5/8-11X2.00
W43-56-56	W104-56-56	3.50	3.50	5.35	5.98	2.750	4.750	2.19	1.06	4.095	3.500	3 1/2-8	.656	5/8-11	241	5/8-11X2.00
W43-64-64	W104-64-64	4.00	4.00	5.75	6.38	3.062	5.125	2.19	1.06	4.595	3.940	4-8	.656	5/8-11	245	5/8-11X2.00

CODE 62 NPTF THREAD

PART NO. O-RING FIG. 1	PART NO. FLAT FACE FIG. 2	PORT SIZE	PAD SIZE	A	B	C	D	E	F	G	H	J	K	L UNC-2B	MOUNTING HARDWARE	
															O-RING	SHCS
W44-8-8	W45-8-8	.50	.50	1.81	2.21	.718	1.594	1.42	.63	1.000	.502	1/2-14	.344	5/6-18	210	5/16-18X1.25
W44-12-12	W45-12-12	.75	.75	2.17	2.80	.937	2.000	1.38	.83	1.250	.752	3/4-14	.406	3/8-16	214	3/8-16X1.50
W44-16-16	W45-16-16	1.00	1.00	2.56	3.19	1.093	2.250	1.65	.98	1.560	1.002	1-11.5	.492	7/16-14	219	7/16-14X1.75
W44-20-20	W45-20-20	1.25	1.25	3.07	3.75	1.250	2.625	1.77	1.06	1.750	1.252	1 1/4-11.5	.531	1/2-13	222	1/2-13X1.75
W44-24-24	W45-24-24	1.50	1.50	3.70	4.41	1.437	3.125	1.97	1.18	2.115	1.502	1 1/2-11.5	.656	5/8-11	225	5/8-11X2.25
W44-32-32	W45-32-32	2.00	2.00	4.50	5.28	1.750	3.812	2.56	1.46	2.490	2.002	2-11.5	.781	3/4-10	228	3/4-10X2.75

Mounting kit available on o-ring grooved flanges by simply adding suffix letter 'U' to part number.

FLOW, NEEDLE & CHECK VALVES

HYDRAULIC BALL VALVES

WELD COUPLINGS

FLANGES - CARBON STEEL

FLANGES - STAINLESS STEEL

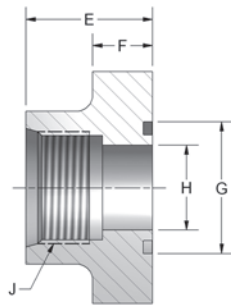
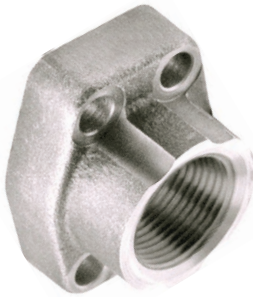

Figure 1

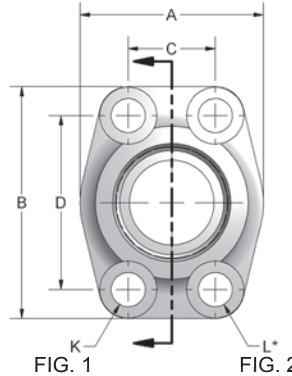

FIG. 1

FIG. 2

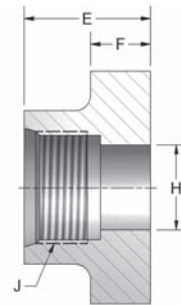

Figure 2

*No Spotface

CODE 61 SAE STRAIGHT THREAD

PART NO. O-RING FIG. 1	PART NO. FLAT FACE FIG. 2	PORT SIZE	PAD SIZE	A	B	C	D	E	F	G	H	J	K	L UNC-2B	MOUNTING HARDWARE	
															O-RING	SHCS
W46-8-8	W106-8-8	.50	.50	1.81	2.13	.688	1.500	1.42	.63	1.000	.502	3/4-16	.344	5/16-18	210	5/16-18X1.25
W46-12-12	W106-12-12	.75	.75	1.97	2.56	.875	1.875	1.42	.71	1.250	.752	1 1/16-12	.406	3/8-16	214	3/8-16X1.50
W46-16-16	W106-16-16	1.00	1.00	2.17	2.75	1.031	2.062	1.50	.71	1.560	1.002	1 5/16-12	.406	3/8-16	219	3/8-16X1.50
W46-20-20	W106-20-20	1.25	1.25	2.68	3.12	1.188	2.312	1.61	.83	1.750	1.252	1 5/8-12	.469	7/16-14	222	7/16-14X1.75
W46-24-24	W106-24-24	1.50	1.50	3.07	3.66	1.406	2.750	1.77	.98	2.115	1.502	1 7/8-12	.531	1/2-13	225	1/2-13X1.75
*W46-32-32	W106-32-32	2.00	2.00	3.54	4.00	1.688	3.062	1.77	.98	2.490	2.002	2 1/2-12	.531	1/2-13	228	1/2-13X1.75
**W46-40-40	W106-40-40	2.50	2.50	4.09	4.49	2.000	3.500	1.97	.98	3.000	2.500	3-12	.530	1/2-13	232	1/2-13X1.75
**W46-48-48	W106-48-48	3.00	3.00	4.88	5.28	2.440	4.190	1.97	1.06	3.620	3.000	3 1/2-12	.660	5/8-11	237	5/8-11X2.00
**W46-64-64	W106-64-64	4.00	4.00	5.74	6.38	3.060	5.130	2.19	1.06	4.600	4.000	4 1/2-12	.660	5/8-11	245	5/8-11X2.00

*1000 PSI max for W46-32-32

**Consult Factory For Working Pressure

CODE 62 SAE STRAIGHT THREAD

PART NO. O-RING FIG. 1	PART NO. FLAT FACE FIG. 2	PORT SIZE	PAD SIZE	A	B	C	D	E	F	G	H	J	K	L UNC-2B	MOUNTING HARDWARE	
															O-RING	SHCS
W48-8-8	W49-8-8	.50	.50	1.81	2.21	.718	1.594	1.42	.63	1.000	.502	3/4-16	.344	5/16-18	210	5/16-18X1.25
W48-12-12	W49-12-12	.75	.75	2.17	2.80	.937	2.000	1.38	.83	1.250	.752	1 1/16-12	.406	3/8-16	214	3/8-16X1.50
W48-16-16	W49-16-16	1.00	1.00	2.56	3.19	1.093	2.250	1.65	.98	1.560	1.002	1 5/16-12	.492	7/16-14	219	7/16-14X1.75
W48-20-20	W49-20-20	1.25	1.25	3.07	3.75	1.250	2.625	1.77	1.06	1.750	1.252	1 5/8-12	.531	1/2-13	222	1/2-13X1.75
W48-24-24	W49-24-24	1.50	1.50	3.70	4.41	1.437	3.125	1.97	1.18	2.115	1.502	1 7/8-12	.656	5/8-11	225	5/8-11X2.25
W48-32-32	W49-32-32	2.00	2.00	4.50	5.28	1.750	3.812	2.56	1.46	2.490	2.002	2 1/2-12	.781	3/4-10	228	3/4-10X2.75

Mounting kit available on o-ring grooved flanges by simply adding suffix letter 'U' to part number.

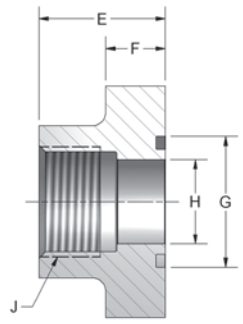
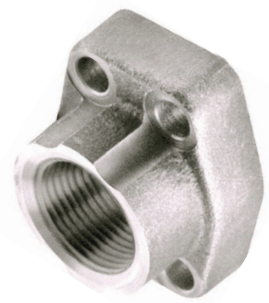

Figure 1

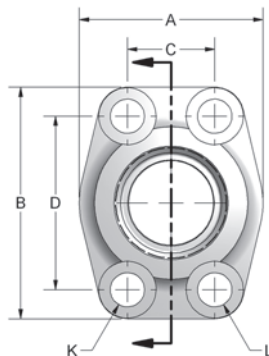

FIG. 1 FIG. 2

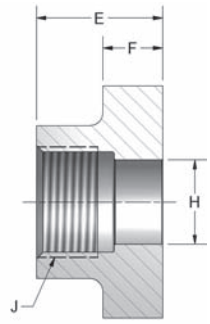

Figure 2

*No Spotface

CODE 61 BSPP THREAD																
PART NO. O-RING FIG. 1	PART NO. FLAT FACE FIG. 2	PORT SIZE	PAD SIZE	A	B	C	D	E	F	G	H	J BSPP	K	L UNC-2B	MOUNTING HARDWARE	
															O-RING	SHCS
W192-8-8	W193-8-8	.50	.50	1.81	2.13	.688	1.500	1.42	.63	1.000	.502	.50-14	.344	5/16-18	210	5/16-18X1.25
W192-12-12	W193-12-12	.75	.75	1.97	2.56	.875	1.875	1.42	.71	1.250	.752	.75-14	.406	3/8-16	214	3/8-16X1.50
W192-16-16	W193-16-16	1.00	1.00	2.17	2.75	1.031	2.062	1.50	.71	1.560	1.002	1.00-11	.406	3/8-16	219	3/8-16X1.50
W192-20-20	W193-20-20	1.25	1.25	2.68	3.12	1.188	2.312	1.61	.83	1.750	1.252	1.25-11	.469	7/16-14	222	7/16-14X1.75
W192-24-24	W193-24-24	1.50	1.50	3.07	3.66	1.406	2.750	1.77	.98	2.115	1.502	1.50-11	.531	1/2-13	225	1/2-13X1.75
W192-32-32	W193-32-32	2.00	2.00	3.54	4.00	1.688	3.062	1.77	.98	2.490	2.002	2.00-11	.531	1/2-13	228	1/2-13X1.75

CODE 62 BSPP THREAD																
PART NO. O-RING FIG. 1	PART NO. FLAT FACE FIG. 2	PORT SIZE	PAD SIZE	A	B	C	D	E	F	G	H	J BSPP	K	L UNC-2B	MOUNTING HARDWARE	
															O-RING	SHCS
W194-8-8	W195-8-8	.50	.50	1.81	2.21	.718	1.594	1.42	.63	1.000	.502	.50-14	.344	5/16-18	210	5/16-18X1.25
W194-12-12	W195-12-12	.75	.75	2.17	2.80	.937	2.000	1.38	.83	1.250	.752	.75-14	.406	3/8-16	214	3/8-16X1.50
W194-16-16	W195-16-16	1.00	1.00	2.56	3.19	1.093	2.250	1.65	.98	1.560	1.002	1.00-11	.492	7/16-14	219	7/16-14X1.75
W194-20-20	W195-20-20	1.25	1.25	3.07	3.75	1.250	2.625	1.77	1.06	1.750	1.252	1.25-11	.531	1/2-13	222	1/2-13X1.50
W194-24-24	W195-24-24	1.50	1.50	3.70	4.41	1.437	3.125	1.97	1.18	2.115	1.502	1.50-11	.656	5/8-11	225	5/8-11X2.00
W194-32-32	W195-32-32	2.00	2.00	4.50	5.28	1.750	3.812	2.56	1.46	2.490	2.002	2.00-11	.781	3/4-10	228	3/4-10X2.75

Mounting kit available on o-ring grooved flanges by simply adding suffix letter 'U' to part number.

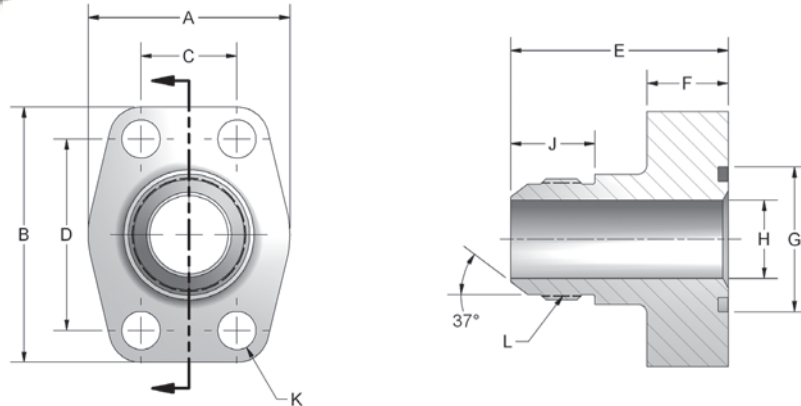

4-Bolt Flange hole pattern per SAE J518. Male JIC Thread per SAE J514.

CODE 61 MALE JIC														
PART NO.	PAD SIZE	A	B	C	D	E	F	G	H	J	K	L	MOUNTING	
													O-RING	SHCS
W300-8-8	.50	1.81	2.13	.688	1.500	2.00	.88	1.000	.394	.657	.344	3/4-16	210	5/16-18X1.25
W300-12-12	.75	1.97	2.56	.875	1.875	2.29	.88	1.250	.611	.864	.413	1 1/16-12	214	3/8-16X1.50
W300-16-16	1.00	2.17	2.75	1.031	2.062	2.35	.88	1.560	.844	.911	.413	1 5/16-12	219	3/8-16X1.50
W300-20-20	1.25	2.68	3.12	1.188	2.312	2.49	.88	1.750	1.078	.958	.469	1 5/8-12	222	7/16-14X1.75
W300-24-24	1.50	3.07	3.66	1.406	2.750	2.81	.98	2.115	1.318	1.083	.531	1 7/8-12	225	1/2-13X1.75

CODE 62 MALE JIC														
PART NO.	PAD SIZE	A	B	C	D	E	F	G	H	J	K	L	MOUNTING	
													O-RING	SHCS
W600-8-8	.50	1.81	2.21	.719	1.594	1.75	.88	1.000	.394	.657	.344	3/4-16	210	5/16-18X1.25
W600-12-12	.75	2.17	2.80	.937	2.000	2.31	.88	1.250	.611	.864	.413	1-1/16-12	214	3/8-16X1.50
W600-16-16	1.00	2.56	3.19	1.093	2.250	2.62	.98	1.560	.844	.911	.492	1-5/16-12	219	7/16-14X1.75
W600-20-20	1.25	3.07	3.75	1.250	2.625	2.81	1.06	1.750	1.078	.958	.531	1-5/8-12	222	1/2-13X1.75
W600-24-24	1.50	3.70	4.41	1.437	3.125	3.25	1.18	2.115	1.318	1.083	.656	1-7/8-12	225	5/8-11X2.25

Mounting kit available on o-ring grooved flanges by simply adding suffix letter 'U' to part number.

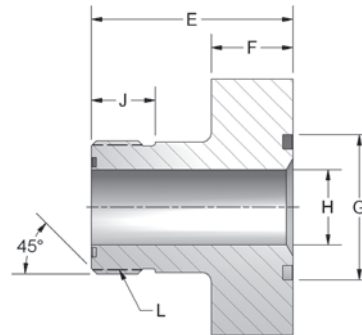
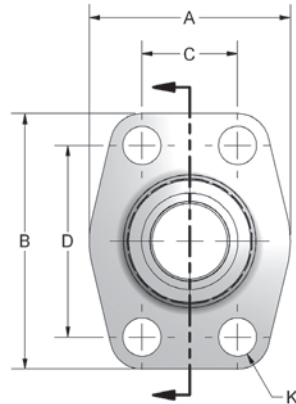

FLOW, NEEDLE & CHECK VALVES

HYDRAULIC BALL VALVES

WELD COUPLINGS

CODE 61 MALE ORFS														
PART NO.	PAD SIZE	A	B	C	D	E	F	G	H	J	K	L	MOUNTING	
													O-RING	SHCS
W304-8-8	.50	1.81	2.13	.688	1.500	1.75	.88	1.000	.394	.504	.344	13/16-16	210	5/16-18X1.25
W304-12-12	.75	1.97	2.56	.875	1.875	2.00	.88	1.250	.611	.670	.413	1 3/16-12	214	3/8-16X1.50
W304-16-16	1.00	2.17	2.75	1.031	2.062	2.00	.88	1.560	.811	.689	.413	1 7/16-12	219	3/8-16X1.50
W304-20-20	1.25	2.68	3.12	1.188	2.312	2.25	.88	1.750	1.024	.689	.469	1 11/16-12	222	7/16-14X1.75
W304-24-24	1.50	3.07	3.66	1.406	2.750	2.50	.98	2.115	1.260	.689	.531	2-12	225	1/2-13X2.00

FLANGES - CARBON STEEL

CODE 62 MALE ORFS														
PART NO.	PAD SIZE	A	B	C	D	E	F	G	H	J	K	L	MOUNTING	
													O-RING	SHCS
W604-8-8	.50	1.81	2.21	.719	1.594	1.75	.88	1.000	.394	.504	.344	13/16-16	210	5/16-18X1.25
W604-12-12	.75	2.17	2.80	.937	2.000	2.25	.88	1.250	.611	.670	.413	1 3/16-12	214	3/8-16X1.50
W604-16-16	1.00	2.56	3.19	1.093	2.250	2.50	.98	1.560	.811	.689	.492	1 7/16-12	219	7/16-14X1.75
W604-20-20	1.25	3.07	3.75	1.250	2.625	2.62	1.06	1.750	1.024	.689	.531	1 11/16-12	222	1/2-13X1.75
W604-24-24	1.50	3.70	4.41	1.437	3.125	2.88	1.18	2.115	1.260	.689	.656	2-12	225	5/8-11X2.25

FLANGES - STAINLESS STEEL

Mounting kit available on o-ring grooved flanges by simply adding suffix letter 'U' to part number.

FLOW, NEEDLE & CHECK VALVES

HYDRAULIC BALL VALVES

WELD COUPLINGS

FLANGES - CARBON STEEL

FLANGES - STAINLESS STEEL

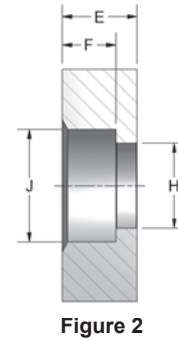
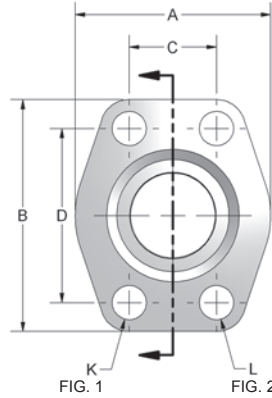
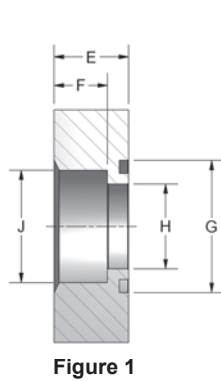

Mounting kit available on o-ring grooved flanges by simply adding suffix letter 'U' to part number.

CODE 61 FLAT SOCKET WELD - PIPE																
PART NO. O-RING FIG. 1	PART NO. FLAT FACE FIG. 2	PIPE SIZE	PAD SIZE	A	B	C	D	E	F	G	H	J	K	L	MOUNTING HARDWARE	
															O-RING	SHCS
W4-8-8	W61-8-8	.50	.50	1.813	2.125	.688	1.500	.750	.560	1.000	.502	.855	.344	5/16-18	210	5/16-18X1.50
W4-12-12	W61-12-12	.75	.75	2.063	2.563	.875	1.875	.750	.560	1.250	.752	1.062	.406	3/8-16	214	3/8-16X1.50
W4-16-16	W61-16-16	1.00	1.00	2.313	2.75	1.031	2.063	.880	.630	1.560	1.002	1.328	.406	3/8-16	219	3/8-16X1.75
W4-20-20	W61-20-20	1.25	1.25	2.875	3.125	1.188	2.313	.940	.690	1.750	1.252	1.672	.469	7/16-14	222	7/16-14X1.75
W4-24-24	W61-24-24	1.50	1.50	3.25	3.688	1.406	2.75	1.190	.750	2.115	1.502	1.922	.531	1/2-13	225	1/2-13X2.25
W4-32-32	W61-32-32	2.00	2.00	3.813	4.00	1.688	3.063	1.380	.875	2.490	2.002	2.406	.531	1/2-13	228	1/2-13X2.50
W4-40-40	W61-40-40	2.50	2.50	4.281	4.50	2.000	3.500	1.750	1.00	2.995	2.502	2.906	.531	1/2-13	232	1/2-13X2.75
W4-48-48	W61-48-48	3.00	3.00	5.156	5.313	2.438	4.188	2.120	1.250	3.615	3.002	3.547	.656	5/8-11	237	5/8-11X3.50

CODE 62 FLAT SOCKET WELD - PIPE																
PART NO. O-RING FIG. 1	PART NO. FLAT FACE FIG. 2	PIPE SIZE	PAD SIZE	A	B	C	D	E	F	G	H	J	K	L	MOUNTING HARDWARE	
															O-RING	SHCS
W59-8-8	W60-8-8	.50	.50	1.94	2.30	.718	1.594	1.25	.560	1.000	.502	.855	.344	5/16-18	210	5/16-18X2.00
W59-12-12	W60-12-12	.75	.75	2.50	2.95	.937	2.000	1.250	.560	1.250	.752	1.062	.406	3/8-16	214	3/8-16X2.00
W59-16-16	W60-16-16	1.00	1.00	2.75	3.19	1.093	2.250	1.500	.630	1.560	1.002	1.328	.492	7/16-14	219	7/16-14X2.50
W59-20-20	W60-20-20	1.25	1.25	3.06	3.75	1.250	2.625	1.500	.690	1.750	1.252	1.672	.531	1/2-13	222	1/2-13X2.50
W59-24-24	W60-24-24	1.50	1.50	3.75	4.44	1.437	3.125	1.750	.750	2.115	1.502	1.922	.656	5/8-11	225	5/8-11X3.00
W59-32-32	W60-32-32	2.00	2.00	4.50	5.25	1.750	3.812	1.750	.875	2.490	2.002	2.406	.781	3/4-10	228	3/4-10X3.00
*W59-40-40	*W60-40-40	2.50	2.50	5.87	6.87	2.312	4.875	2.060	1.000	2.995	2.502	2.906	.906	7/8-9	232	**7/8-9X3.50
*W59-48-48	*W60-48-48	3.00	3.00	7.00	8.50	2.812	6.000	2.620	1.250	3.615	3.002	3.547	1.190	1-1/8-7	237	**1 1/8-7X4.50

*3000 PSI Max Working Pressure

**HHCS

CODE 61 FLAT SOCKET WELD - PIPE - ALL SIZES 500 PSI																
PART NO. O-RING FIG. 1	PART NO. FLAT FACE FIG. 2	PIPE SIZE	PAD SIZE	A	B	C	D	E	F	G	H	J	K	L UNC-2B	MOUNTING HARDWARE	
															O-RING	SHCS
W72-48-48	W91-48-48	3.00	3.00	5.12	5.31	2.438	4.188	1.380	1.120	3.615	3.002	3.547	.656	5/8-11	237	5/8-11X2.50
W72-56-56	W91-56-56	3.50	3.50	5.50	6.00	2.750	4.750	1.440	1.190	4.095	3.502	4.047	.656	5/8-11	241	5/8-11X2.75
W72-64-64	W91-64-64	4.00	4.00	6.00	6.38	3.062	5.125	1.500	1.250	4.595	4.002	4.578	.656	5/8-11	245	5/8-11X2.75
W72-80-80	W91-80-80	5.00	5.00	7.12	7.25	3.625	6.000	1.750	1.380	5.595	5.002	5.641	.656	5/8-11	253	5/8-11X3.00

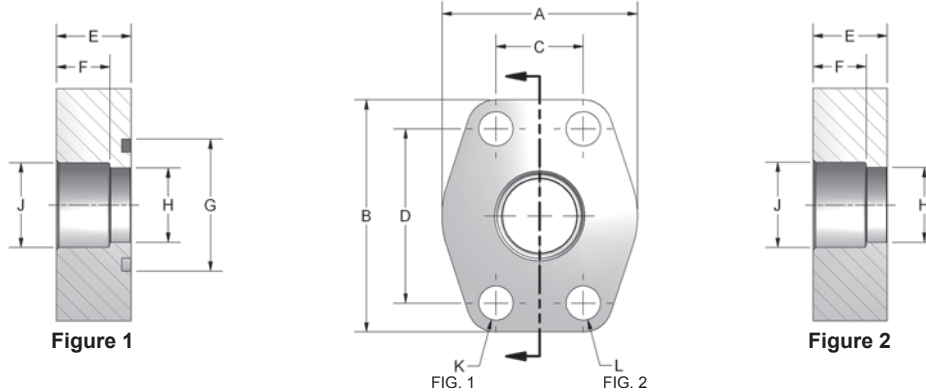

Mounting kit available on o-ring grooved flanges by simply adding suffix letter 'U' to part number.

CODE 61 FLAT SOCKET WELD - TUBE																
PART NO. O-RING FIG. 1	PART NO. FLAT FACE FIG. 2	TUBE SIZE	PAD SIZE	A	B	C	D	E	F	G	H	J	K	L	MOUNTING HARDWARE	
															O-RING	SHCS
W6-12-12	W62-12-12	.75	.75	2.060	2.560	.875	1.875	.750	.560	1.250	.625	.752	.406	3/8-16	214	3/8-16X1.50
W6-16-12	W62-16-12	1.00	.75	2.060	2.560	.875	1.875	.750	.560	1.250	.750	1.002	.406	3/8-16	214	3/8-16X1.50
W6-16-16	W62-16-16	1.00	1.00	2.310	2.750	1.031	2.062	.880	.630	1.560	.875	1.002	.406	3/8-16	219	3/8-16X1.75
W6-20-16	W62-20-16	1.25	1.00	2.310	2.750	1.031	2.062	.880	.630	1.560	1.000	1.252	.406	3/8-16	219	3/8-16X1.75
W6-20-20	W62-20-20	1.25	1.25	2.880	3.120	1.188	2.312	.940	.690	1.750	1.125	1.252	.469	7/16-14	222	7/16-14X1.75
W6-24-20	W62-24-20	1.50	1.25	2.880	3.120	1.188	2.312	.940	.690	1.750	1.250	1.502	.469	7/16-14	222	7/16-14X1.75
W6-24-24	W62-24-24	1.50	1.50	3.250	3.690	1.406	2.750	1.190	.750	2.115	1.375	1.502	.531	1/2-13	225	1/2-13X2.25
W6-28-24	W62-28-24	1.75	1.50	3.250	3.690	1.406	2.750	1.190	.750	2.115	1.500	1.752	.531	1/2-13	225	1/2-13X2.25
W6-32-32	W62-32-32	2.00	2.00	3.810	4.000	1.688	3.062	1.380	.875	2.490	1.875	2.002	.531	1/2-13	228	1/2-13X2.50
W6-36-32	W62-36-32	2.25	2.00	3.810	4.000	1.688	3.062	1.380	.875	2.490	2.000	2.252	.531	1/2-13	228	1/2-13X2.50

CODE 62 FLAT SOCKET WELD - TUBE																
PART NO. O-RING FIG. 1	PART NO. FLAT FACE FIG. 2	TUBE SIZE	PAD SIZE	A	B	C	D	E	F	G	H	J	K	L	MOUNTING HARDWARE	
															O-RING	SHCS
W58-12-12	W63-12-12	.75	.75	2.50	2.95	.937	2.000	1.250	.560	1.250	.625	.752	.406	3/8-16	214	3/8-16X2.00
W58-16-12	W63-16-12	1.00	.75	2.50	2.95	.937	2.000	1.250	.560	1.250	.750	1.002	.406	3/8-16	214	3/8-16X2.00
W58-16-16	W63-16-16	1.00	1.00	2.75	3.19	1.093	2.250	1.500	.630	1.560	.875	1.002	.492	7/16-14	219	7/16-14X2.50
W58-20-16	W63-20-16	1.25	1.00	2.75	3.19	1.093	2.250	1.500	.630	1.560	1.000	1.252	.492	7/16-14	219	7/16-14X2.50
W58-20-20	W63-20-20	1.25	1.25	3.06	3.75	1.250	2.625	1.500	.690	1.750	1.125	1.252	.531	1/2-13	222	1/2-13X2.50
W58-24-20	W63-24-20	1.50	1.25	3.06	3.75	1.250	2.625	1.500	.690	1.750	1.250	1.502	.531	1/2-13	222	1/2-13X2.50
W58-24-24	W63-24-24	1.50	1.50	3.75	4.44	1.437	3.125	1.750	.750	2.115	1.375	1.502	.656	5/8-11	225	5/8-11X3.00
W58-28-24	W63-28-24	1.75	1.50	3.75	4.44	1.437	3.125	1.750	.750	2.115	1.500	1.752	.656	5/8-11	225	5/8-11X3.00
W58-32-32	W63-32-32	2.00	2.00	4.50	5.25	1.750	3.812	1.750	.875	2.490	1.875	2.002	.781	3/4-10	228	3/4-10X3.00
W58-36-32	W63-36-32	2.25	2.00	4.50	5.25	1.750	3.812	1.750	.875	2.490	2.000	2.252	.781	3/4-10	228	3/4-10X3.00

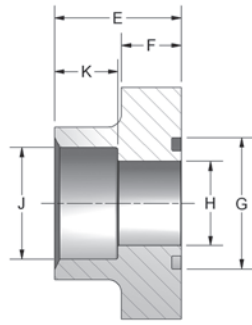
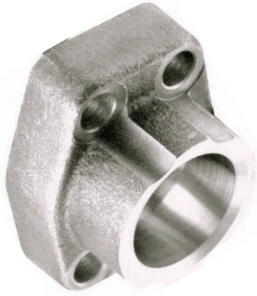

Figure 1

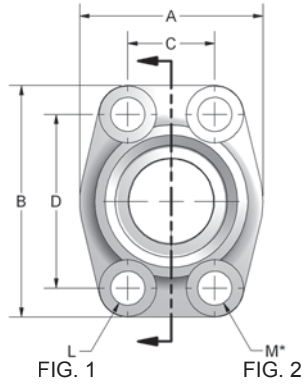

FIG. 1 FIG. 2

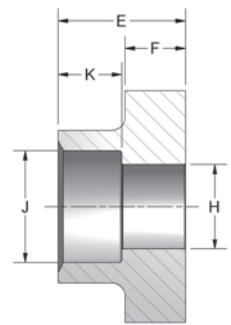

Figure 2

*No Spotface

CODE 61 DEEP SOCKET WELD - PIPE																	
PART NO. O-RING FIG. 1	PART NO. FLAT FACE FIG. 2	PIPE SIZE	PAD SIZE	A	B	C	D	E	F	G	H	J	K	L	M UNC-2B	MOUNTING HARDWARE	
																O-RING	SHCS
W31-8-8	W3-8-8	.50	.50	1.81	2.13	.688	1.500	1.42	.63	1.000	.502	.855	.75	.344	5/16-18	210	5/16-18X1.25
W31-12-12	W3-12-12	.75	.75	1.97	2.56	.875	1.875	1.42	.71	1.250	.752	1.062	.75	.406	3/8-16	214	3/8-16X1.50
W31-16-16	W3-16-16	1.00	1.00	2.17	2.75	1.031	2.062	1.50	.71	1.560	1.002	1.328	.75	.406	3/8-16	219	3/8-16X1.50
W31-20-20	W3-20-20	1.25	1.25	2.68	3.12	1.188	2.312	1.61	.83	1.750	1.252	1.672	.87	.469	7/16-14	222	7/16-14X1.75
W31-24-24	W3-24-24	1.50	1.50	3.07	3.66	1.406	2.750	1.77	.98	2.115	1.502	1.922	.94	.531	1/2-13	225	1/2-13X1.75
W31-32-32	W3-32-32	2.00	2.00	3.54	4.00	1.688	3.062	1.77	.98	2.490	2.002	2.406	1.02	.531	1/2-13	228	1/2-13X1.75
W31-40-40	W3-40-40	2.50	2.50	4.09	4.49	2.000	3.500	1.97	.98	2.995	2.502	2.908	1.18	.531	1/2-13	232	1/2-13X1.75
W31-48-48	W3-48-48	3.00	3.00	4.88	5.28	2.438	4.188	1.97	1.06	3.615	3.002	3.547	1.34	.656	5/8-11	237	5/8-11X2.00

CODE 62 DEEP SOCKET WELD - PIPE																	
PART NO. O-RING FIG. 1	PART NO. FLAT FACE FIG. 2	PIPE SIZE	PAD SIZE	A	B	C	D	E	F	G	H	J	K	L	M UNC-2B	MOUNTING HARDWARE	
																O-RING	SHCS
W81-8-8	W80-8-8	.50	.50	1.81	2.21	.718	1.594	1.42	.63	1.000	.502	.855	.75	.344	5/16-18	210	5/16-18X1.25
W81-12-12	W80-12-12	.75	.75	2.17	2.80	.937	2.000	1.38	.83	1.250	.752	1.062	.87	.406	3/8-16	214	3/8-16X1.50
W81-16-16	W80-16-16	1.00	1.00	2.56	3.19	1.093	2.250	1.65	.98	1.560	1.002	1.328	.87	.492	7/16-14	219	7/16-14X1.75
W81-20-20	W80-20-20	1.25	1.25	3.07	3.75	1.250	2.625	1.77	1.06	1.750	1.252	1.672	.98	.531	1/2-13	222	1/2-13X1.75
W81-24-24	W80-24-24	1.50	1.50	3.70	4.41	1.437	3.125	1.97	1.18	2.115	1.502	1.922	1.10	.656	5/8-11	225	5/8-11X2.25
W81-32-32	W80-32-32	2.00	2.00	4.50	5.28	1.750	3.812	2.56	1.46	2.490	2.002	2.406	.94	.781	3/4-10	228	3/4-10X2.75

Mounting kit available on o-ring grooved flanges by simply adding suffix letter 'U' to part number.

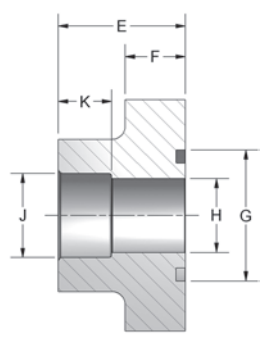

Figure 1

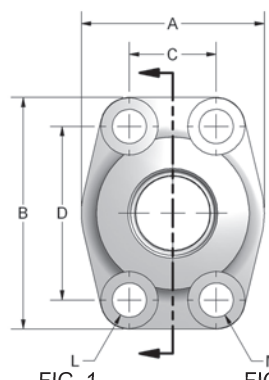

FIG. 1 FIG. 2

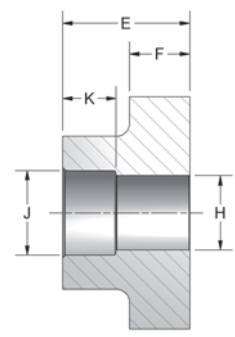

Figure 2

*No Spotface

CODE 61 DEEP SOCKET WELD - TUBE																	
PART NO. O-RING FIG. 1	PART NO. FLAT FACE FIG. 2	TUBE SIZE	PAD SIZE	A	B	C	D	E	F	G	H	J	K	L	M UNC-2B	MOUNTING HARDWARE	
																O-RING	SHCS
W51-12-12	W5-12-12	.75	.75	1.97	2.56	.875	1.875	1.42	.71	1.250	.625	.752	.560	.406	3/8-16	214	3/8-16X1.50
W51-16-12	W5-16-12	1.00	.75	1.97	2.56	.875	1.875	1.42	.71	1.250	.750	1.002	.560	.406	3/8-16	214	3/8-16X1.50
W51-16-16	W5-16-16	1.00	1.00	2.17	2.75	1.031	2.062	1.50	.71	1.560	.875	1.002	.630	.406	3/8-16	219	3/8-16X1.50
W51-20-16	W5-20-16	1.25	1.00	2.17	2.75	1.031	2.062	1.50	.71	1.560	1.000	1.252	.630	.406	3/8-16	219	3/8-16X1.50
W51-20-20	W5-20-20	1.25	1.25	2.68	3.12	1.188	2.312	1.61	.83	1.750	1.125	1.252	.690	.469	7/16-14	222	7/16-14X1.75
W51-24-20	W5-24-20	1.50	1.25	2.68	3.12	1.188	2.312	1.61	.83	1.750	1.250	1.502	.690	.469	7/16-14	222	7/16-14X1.75
W51-24-24	W5-24-24	1.50	1.50	3.07	3.66	1.406	2.750	1.77	.98	2.115	1.375	1.502	.750	.531	1/2-13	225	1/2-13X1.75
W51-28-24	W5-28-24	1.75	1.50	3.07	3.66	1.406	2.750	1.77	.98	2.115	1.500	1.752	.750	.531	1/2-13	225	1/2-13X1.75
W51-32-32	W5-32-32	2.00	2.00	3.54	4.00	1.688	3.062	1.77	.98	2.490	1.875	2.002	.870	.531	1/2-13	228	1/2-13X1.75
W51-36-32	W5-36-32	2.25	2.00	3.54	4.00	1.688	3.062	1.77	.98	2.490	2.000	2.252	.870	.531	1/2-13	228	1/2-13X1.75
W51-40-40	W5-40-40	2.50	2.50	4.09	4.49	2.000	3.500	1.97	.98	2.995	2.375	2.502	1.000	.531	1/2-13	232	1/2-13X1.75
W51-44-40	W5-44-40	2.75	2.50	4.09	4.49	2.000	3.500	1.97	.98	2.995	2.500	2.752	1.000	.531	1/2-13	232	1/2-13X1.75

Mounting kit available on o-ring grooved flanges by simply adding suffix letter 'U' to part number.

FLOW, NEEDLE & CHECK VALVES

HYDRAULIC BALL VALVES

WELD COUPLINGS

FLANGES - CARBON STEEL

FLANGES - STAINLESS STEEL

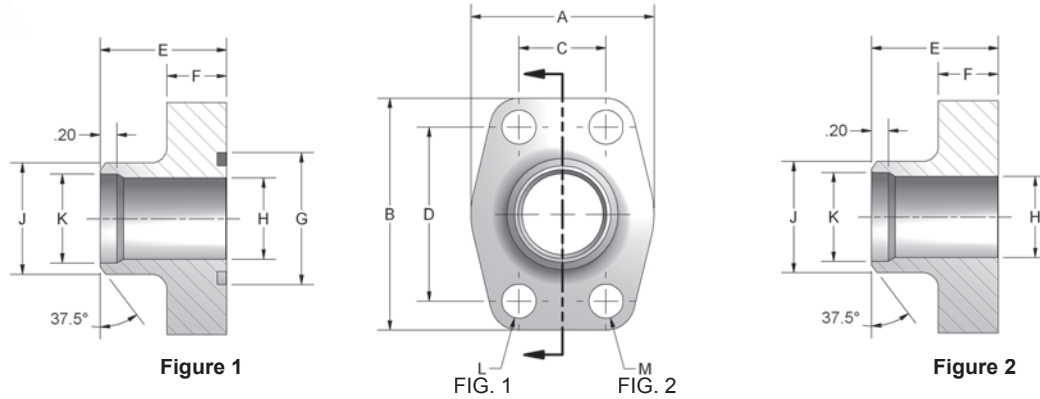
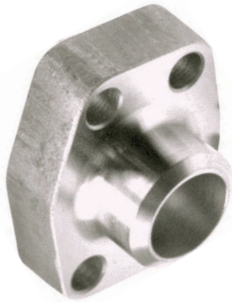

CODE 61 BUTT WELD - SCHEDULE 40 PIPE

PART NO. O-RING FIG. 1	PART NO. FLAT FACE FIG. 2	PIPE SIZE	PAD SIZE	A	B	C	D	E	F	G	H	J	K	L	M UNC-2B	MOUNTING HARDWARE	
																O-RING	SHCS
W35-8	W34-8	.50	.50	1.81	2.13	.688	1.500	1.42	.63	1.000	.548	.840	.624	.344	5/16-18	210	5/16-18X1.25
W35-12	W34-12	.75	.75	1.97	2.56	.875	1.875	1.42	.71	1.250	.744	1.050	.846	.406	3/8-16	214	3/8-16X1.50
W35-16	W34-16	1.00	1.00	2.17	2.75	1.031	2.062	1.50	.71	1.560	.959	1.315	1.051	.406	3/8-16	219	3/8-16X1.50
W35-20	W34-20	1.25	1.25	2.68	3.12	1.188	2.312	1.61	.83	1.750	1.280	1.660	1.382	.469	7/16-14	222	7/16-14X1.75
W35-24	W34-24	1.50	1.50	3.07	3.66	1.406	2.750	1.73	.98	2.115	1.502	1.900	1.612	.531	1/2-13	225	1/2-13X1.75
W35-32	W34-32	2.00	2.00	3.54	4.00	1.688	3.062	1.77	.98	2.490	1.941	2.375	2.069	.531	1/2-13	228	1/2-13X1.75
W35-40	W34-40	2.50	2.50	4.09	4.49	2.000	3.500	1.97	.98	2.995	2.325	2.875	2.471	.531	1/2-13	232	1/2-13X1.75
W35-48	W34-48	3.00	3.00	4.88	5.28	2.438	4.188	1.97	1.06	3.615	2.902	3.500	3.070	.656	5/8-11	237	5/8-11X2.00

CODE 61 BUTT WELD - SCHEDULE 80 PIPE

PART NO. O-RING FIG. 1	PART NO. FLAT FACE FIG. 2	PIPE SIZE	PAD SIZE	A	B	C	D	E	F	G	H	J	L	M UNC-2B	MOUNTING HARDWARE	
															O-RING	SHCS
W24-8	W23-8	.50	.50	1.81	2.13	.688	1.500	1.42	.63	1.000	.548	.840	.344	5/16-18	210	5/16-18X1.25
W24-12	W23-12	.75	.75	1.97	2.56	.875	1.875	1.42	.71	1.250	.744	1.050	.406	3/8-16	214	3/8-16X1.50
W24-16	W23-16	1.00	1.00	2.17	2.75	1.031	2.062	1.50	.71	1.560	.959	1.315	.406	3/8-16	219	3/8-16X1.50
W24-20	W23-20	1.25	1.25	2.68	3.12	1.188	2.312	1.61	.83	1.750	1.280	1.660	.469	7/16-14	222	7/16-14X1.75
W24-24	W23-24	1.50	1.50	3.07	3.66	1.406	2.750	1.73	.98	2.115	1.502	1.900	.531	1/2-13	225	1/2-13X1.75
W24-32	W23-32	2.00	2.00	3.54	4.00	1.688	3.062	1.77	.98	2.490	1.941	2.375	.531	1/2-13	228	1/2-13X1.75
W24-40	W23-40	2.50	2.50	4.09	4.49	2.000	3.500	1.97	.98	2.995	2.325	2.875	.531	1/2-13	232	1/2-13X1.75
W24-48	W23-48	3.00	3.00	4.88	5.28	2.438	4.188	1.97	1.06	3.615	2.902	3.500	.656	5/8-11	237	5/8-11X2.00

CODE 61 BUTT WELD - SCHEDULE 160 PIPE

PART NO. O-RING FIG. 1	PART NO. FLAT FACE FIG. 2	PIPE SIZE	PAD SIZE	A	B	C	D	E	F	G	H	J	L	M UNC-2B	MOUNTING HARDWARE	
															O-RING	SHCS
W27-8	W25-8	.50	.50	1.81	2.13	.688	1.500	1.42	.63	1.000	.466	.840	.344	5/16-18	210	5/16-18X1.25
W27-12	W25-12	.75	.75	1.97	2.56	.875	1.875	1.42	.71	1.250	.614	1.050	.406	3/8-16	214	3/8-16X1.50
W27-16	W25-16	1.00	1.00	2.17	2.75	1.031	2.062	1.50	.71	1.560	.817	1.315	.406	3/8-16	219	3/8-16X1.50
W27-20	W25-20	1.25	1.25	2.68	3.12	1.188	2.132	1.61	.83	1.750	1.162	1.660	.469	7/16-14	222	7/16-14X1.75
W27-24	W25-24	1.50	1.50	3.07	3.66	1.406	2.750	1.73	.98	2.115	1.340	1.900	.531	1/2-13	225	1/2-13X1.75
W27-32	W25-32	2.00	2.00	3.54	4.00	1.688	3.062	1.77	.98	2.490	1.689	2.375	.531	1/2-13	228	1/2-13X1.75
W27-40	W25-40	2.50	2.50	4.09	4.49	2.000	3.500	1.97	.98	2.995	2.127	2.875	.531	1/2-13	232	1/2-13X1.75
W27-48	W25-48	3.00	3.00	4.88	5.28	2.438	4.188	1.97	1.06	3.615	2.626	3.500	.656	5/8-11	237	5/8-11X2.00

*NOTE: Also available in sizes 3 1/2", 4", and 5". Consult factory for specifications.

Mounting kit available on o-ring grooved flanges by simply adding suffix letter 'U' to part number.

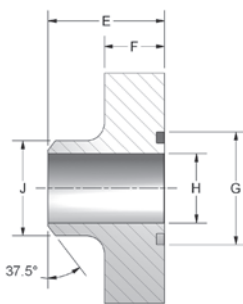

Figure 1

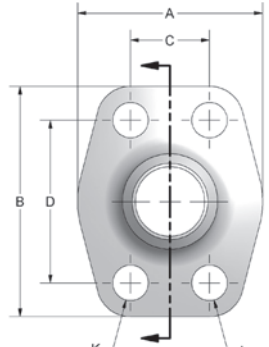

FIG. 1 FIG. 2

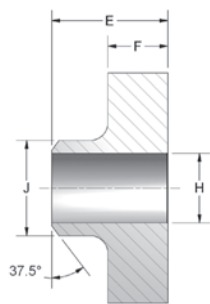

Figure 2



FLOW, NEEDLE & CHECK VALVES

HYDRAULIC BALL VALVES

WELD COUPLINGS

FLANGES - CARBON STEEL

FLANGES - STAINLESS STEEL

CODE 62 BUTT WELD - SCHEDULE 80 PIPE

PART NO. O-RING FIG. 1	PART NO. FLAT FACE FIG. 2	PIPE SIZE	PAD SIZE	A	B	C	D	E	F	G	H	J	K	L UNC-2B	MOUNTING HARDWARE	
															O-RING	SHCS
W28-8	W26-8	.50	.50	1.81	2.21	.718	1.594	1.42	.63	1.000	.548	.840	.344	5/16-18	210	5/16-18X1.25
W28-12	W26-12	.75	.75	2.17	2.80	.937	2.000	1.38	.83	1.250	.744	1.050	.406	3/8-16	214	3/8-16X1.50
W28-16	W26-16	1.00	1.00	2.56	3.19	1.093	2.250	1.61	.83	1.560	.959	1.315	.492	7/16-14	219	7/16-14X1.75
W28-20	W26-20	1.25	1.25	3.07	3.75	1.250	2.625	1.73	.98	1.750	1.280	1.660	.531	1/2-13	222	1/2-13X1.75
W28-24	W26-24	1.50	1.50	3.70	4.41	1.437	3.125	2.17	1.18	2.115	1.502	1.900	.656	5/8-11	225	5/8-11X2.25
W28-32	W26-32	2.00	2.00	4.50	5.28	1.750	3.812	2.56	1.46	2.490	1.941	2.375	.781	3/4-10	228	3/4-10X3.00
*W28-40	*W26-40	2.50	2.50	5.00	6.88	2.312	4.875	2.37	1.50	2.995	2.325	2.875	.906	7/8-9	232	7/8-9X3.00
*W28-48	*W26-48	3.00	3.00	6.00	8.50	2.812	6.000	2.96	2.00	3.615	2.902	3.500	1.190	1 1/8-7	237	1 1/8-7X4.00

CODE 62 BUTT WELD - SCHEDULE 160 PIPE

PART NO. O-RING FIG. 1	PART NO. FLAT FACE FIG. 2	PIPE SIZE	PAD SIZE	A	B	C	D	E	F	G	H	J	K	L UNC-2B	MOUNTING HARDWARE	
															O-RING	SHCS
W30-8	W29-8	.50	.50	1.81	2.21	.718	1.594	1.42	.63	1.000	.466	.840	.344	5/16-18	210	5/16-18X1.25
W30-12	W29-12	.75	.75	2.17	2.80	.937	2.000	1.38	.83	1.250	.614	1.050	.406	3/8-16	214	3/8-16X1.50
W30-16	W29-16	1.00	1.00	2.56	3.19	1.093	2.250	1.61	.83	1.560	.817	1.315	.492	7/16-14	219	7/16-14X1.75
W30-20	W29-20	1.25	1.25	3.07	3.75	1.250	2.625	1.73	.98	1.750	1.162	1.660	.531	1/2-13	222	1/2-13X1.75
W30-24	W29-24	1.50	1.50	3.70	4.41	1.437	3.125	2.17	1.18	2.115	1.340	1.900	.656	5/8-11	225	5/8-11X2.25
W30-32	W29-32	2.00	2.00	4.50	5.28	1.750	3.812	2.56	1.46	2.490	1.689	2.375	.781	3/4-10	228	3/4-10X3.00
*W30-40	*W29-40	2.50	2.50	5.00	6.88	2.312	4.875	2.37	1.50	2.995	2.127	2.875	.906	7/8-9	232	7/8-9X3.00
*W30-48	*W29-48	3.00	3.00	6.00	8.50	2.812	6.000	2.96	2.00	3.615	2.626	3.500	1.190	1 1/8-7	237	1 1/8-7X4.00

CODE 62 BUTT WELD - SCHEDULE XXS PIPE

PART NO. O-RING FIG. 1	PART NO. FLAT FACE FIG. 2	PIPE SIZE	PAD SIZE	A	B	C	D	E	F	G	H	J	K	L UNC-2B	MOUNTING HARDWARE	
															O-RING	SHCS
W33-8	W32-8	.50	.50	1.81	2.21	.718	1.594	1.42	.63	1.000	.254	.840	.344	5/16-18	210	5/16-18X1.25
W33-12	W32-12	.75	.75	2.17	2.80	.937	2.000	1.38	.83	1.250	.436	1.050	.406	3/8-16	214	3/8-16X1.50
W33-16	W32-16	1.00	1.00	2.56	3.19	1.093	2.250	1.61	.83	1.560	.601	1.315	.492	7/16-14	219	7/16-14X1.75
W33-20	W32-20	1.25	1.25	3.07	3.75	1.250	2.625	1.73	.98	1.750	.898	1.660	.531	1/2-13	222	1/2-13X1.75
W33-24	W32-24	1.50	1.50	3.70	4.41	1.437	3.125	2.17	1.18	2.115	1.102	1.900	.656	5/8-11	225	5/8-11X2.25
W33-32	W32-32	2.00	2.00	4.50	5.28	1.750	3.812	2.56	1.46	2.490	1.505	2.375	.781	3/4-10	228	3/4-10X3.00
*W33-40	*W32-40	2.50	2.50	5.00	6.88	2.312	4.875	2.37	1.50	2.995	1.773	2.875	.906	7/8-9	232	7/8-9X3.00
*W33-48	*W32-48	3.00	3.00	6.00	8.50	2.812	6.000	2.96	2.00	3.615	2.302	3.500	1.190	1 1/8-7	237	1 1/8-7X4.00

*Flange Shape Rectangle

3000 PSI Max Working Pressure

Mounting kit available on o-ring grooved flanges by simply adding suffix letter 'U' to part number.

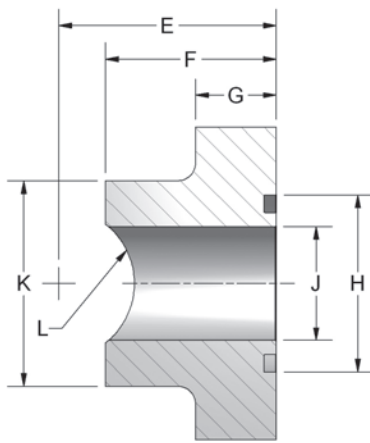
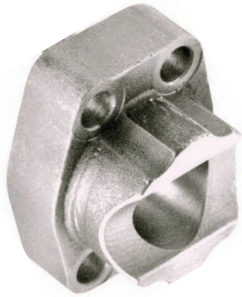

Figure 1

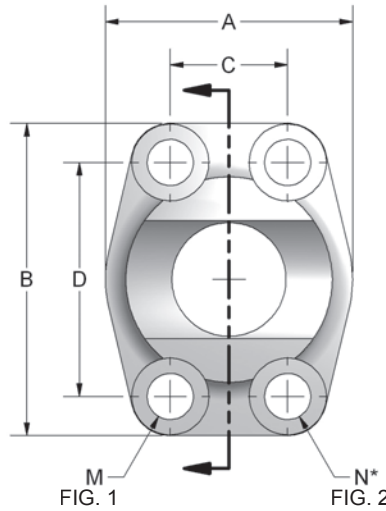

FIG. 1 FIG. 2

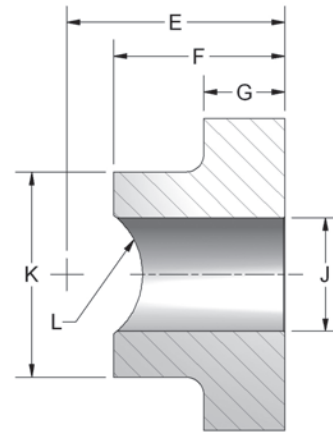

Figure 2

*No Spotface

CODE 61 SADDLE WELD - PIPE

PART NO. O-RING FIG. 1	PART NO. FLAT FACE FIG. 2	PIPE SIZE	PAD SIZE	A	B	C	D	E	F	G	H	J	K	L	M	N UNC-2B	MOUNTING HARDWARE	
																	O-RING	SHCS
W8-12-12	W7-12-12	.75	.75	1.97	2.56	.875	1.875	1.775	1.42	.71	1.250	.752	1.54	.532	.406	3/8-16	214	3/8-16X1.50
W8-16-16	W7-16-16	1.00	1.00	2.17	2.75	1.031	2.062	1.912	1.50	.71	1.560	1.002	1.81	.665	.406	3/8-16	219	3/8-16X1.50
W8-20-20	W7-20-20	1.25	1.25	2.68	3.12	1.188	2.312	2.146	1.61	.83	1.750	1.252	2.22	.837	.469	7/16-14	222	7/16-14X1.75
W8-24-24	W7-24-24	1.50	1.50	3.07	3.66	1.406	2.750	2.290	1.77	.98	2.115	1.502	2.50	.957	.531	1/2-13	225	1/2-13X1.75
W8-32-32	W7-32-32	2.00	2.00	3.54	4.00	1.688	3.062	2.340	1.77	.98	2.490	2.002	3.12	1.200	.531	1/2-13	228	1/2-13X1.75
W8-40-40	W7-40-40	2.50	2.50	4.09	4.49	2.000	3.500	2.660	1.97	.98	2.995	2.502	3.62	1.451	.531	1/2-13	232	1/2-13X1.75

CODE 61 SADDLE WELD - TUBE

PART NO. O-RING FIG. 1	PART NO. FLAT FACE FIG. 2	TUBE SIZE	PAD SIZE	A	B	C	D	E	F	G	H	J	K	L	M	N UNC-2B	MOUNTING HARDWARE	
																	O-RING	SHCS
W87-12-12	W69-12-12	.75	.75	1.97	2.56	.875	1.875	1.420	1.42	.71	1.250	.752	1.54	.382	.406	3/8-16	214	3/8-16X1.50
W87-16-12	W69-16-12	1.00	.75	1.97	2.56	.875	1.875	1.737	1.42	.71	1.250	.752	1.54	.507	.406	3/8-16	214	3/8-16X1.50
W87-16-16	W69-16-16	1.00	1.00	2.17	2.75	1.031	2.062	1.500	1.50	.71	1.560	1.002	1.81	.507	.406	3/8-16	219	3/8-16X1.50
W87-20-16	W69-20-16	1.25	1.00	2.17	2.75	1.031	2.062	1.858	1.50	.71	1.560	1.002	1.81	.632	.406	3/8-16	219	3/8-16X1.50
W87-20-20	W69-20-20	1.25	1.25	2.68	3.12	1.188	2.312	1.665	1.61	.83	1.750	1.252	2.22	.632	.469	7/16-14	222	7/16-14X1.75
W87-24-20	W69-24-20	1.50	1.25	2.68	3.12	1.188	2.312	2.022	1.61	.83	1.750	1.252	2.22	.757	.469	7/16-14	222	7/16-14X1.75
W87-28-24	W69-28-24	1.75	1.50	3.07	3.66	1.406	2.750	2.198	1.77	.98	2.115	1.502	2.50	.882	.531	1/2-13	225	1/2-13X1.75
W87-32-32	W69-32-32	2.00	2.00	3.54	4.00	1.688	3.062	2.262	1.77	.98	2.490	1.691	2.38	1.007	.531	1/2-13	228	1/2-13X1.75
W87-36-32	W69-36-32	2.25	2.00	3.54	4.00	1.688	3.062	2.247	1.77	.98	2.490	2.002	3.12	1.132	.531	1/2-13	228	1/2-13X1.75

Mounting kit available on o-ring grooved flanges by simply adding suffix letter 'U' to part number.

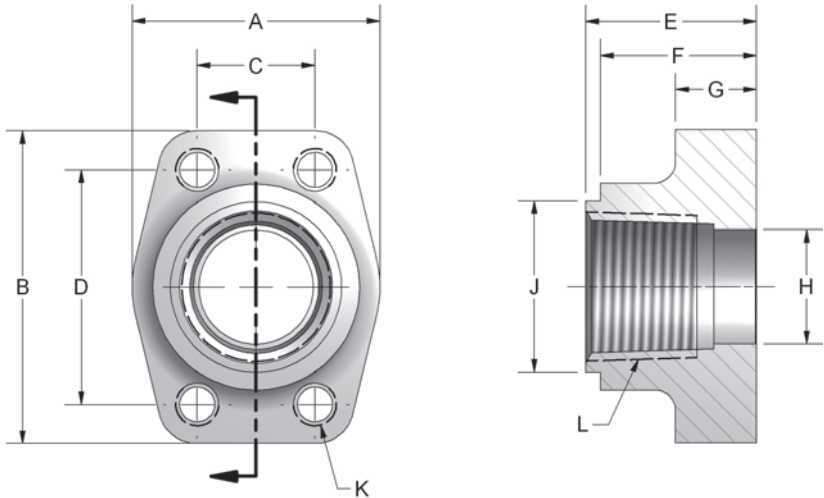

CODE 61 NPTF TANK PILOT													
PART NO.	PIPE	PAD	A	B	C	D	E	F	G	H	J	K UNC-2B	L NPTF
W22-12	.750	.750	1.97	2.56	.875	1.875	1.42	1.30	.71	.752	1.375	3/8-16	3/4-14
W22-16	1.00	1.00	2.17	2.75	1.031	2.062	1.50	1.37	.71	1.002	1.500	3/8-16	1-11.5
W22-20	1.25	1.25	2.68	3.12	1.188	2.312	1.61	1.49	.83	1.252	1.750	7/16-14	1 1/4-11.5
W22-24	1.50	1.50	3.07	3.66	1.406	2.750	1.77	1.64	.98	1.502	2.125	1/2-13	1 1/2-11.5
W22-32	2.00	2.00	3.54	4.00	1.688	3.062	1.77	1.65	.98	2.002	2.500	1/2-13	2-11.5
W22-40	2.50	2.50	4.09	4.49	2.000	3.500	1.97	1.85	.98	2.502	3.250	1/2-13	2 1/2-8
W22-48	3.00	3.00	4.88	5.28	2.438	4.188	1.97	1.85	1.06	3.002	3.625	5/8-11	3-8
W22-56	3.50	3.50	5.35	5.98	2.750	4.750	1.89	1.77	1.06	3.504	4.125	5/8-11	3 1/2-8
W22-64	4.00	4.00	5.75	6.38	3.062	5.125	1.89	1.77	1.06	3.898	4.625	5/8-11	4-8

Female NPTF thread added to facilitate pump suction line and return line applications.

FLOW, NEEDLE & CHECK VALVES

HYDRAULIC BALL VALVES

WELD COUPLINGS

FLANGES - CARBON STEEL

FLANGES - STAINLESS STEEL

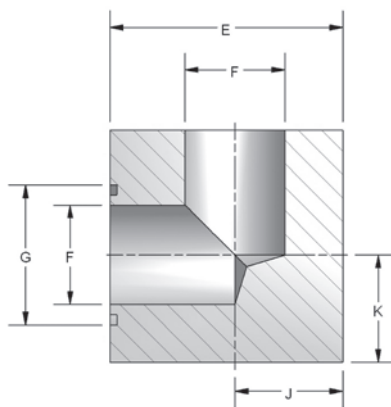

Figure 1

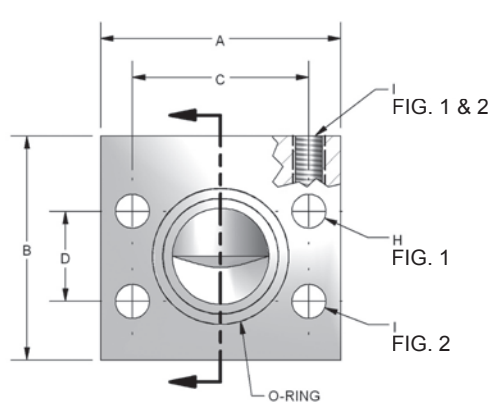

FIG. 1 ONLY

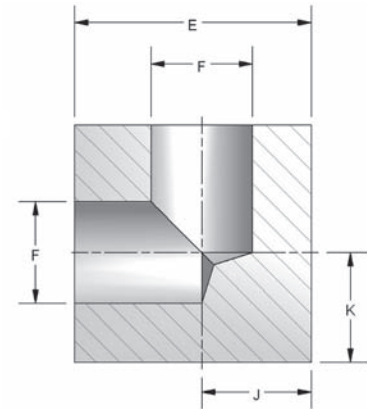

Figure 2

CODE 61 ELBOW BLOCK

PART NO. O-RING FIG. 1	PART NO. FLAT FACE FIG. 2	PAD SIZE	A	B	C	D	E	F	G	H	I UNC-2B	J	K	MOUNTING HARDWARE	
														O-RING	SHCS
W14-12	W15-12	.75	2.62	2.50	1.875	.875	2.25	.75	1.250	.406	3/8-16	1.03	1.03	214	3/8-16X3.00
W14-16	W15-16	1.00	2.82	2.50	2.062	1.031	2.50	1.00	1.560	.406	3/8-16	1.16	1.09	219	3/8-16X3.25
W14-20	W15-20	1.25	3.19	3.00	2.312	1.188	3.00	1.25	1.750	.469	7/16-14	1.44	1.31	222	7/16-14X4.00
W14-24	W15-24	1.50	3.75	3.50	2.750	1.406	3.50	1.50	2.115	.531	1/2-13	1.62	1.62	225	1/2-13X4.50
W14-32	W15-32	2.00	4.00	4.00	3.062	1.688	4.00	1.94	2.490	.531	1/2-13	1.91	1.91	228	1/2-13X5.00

CODE 62 ELBOW BLOCK

PART NO. O-RING FIG. 1	PART NO. FLAT FACE FIG. 2	PAD SIZE	A	B	C	D	E	F	G	H	I UNC-2B	J	K	MOUNTING HARDWARE	
														O-RING	SHCS
W12-12	W13-12	.75	2.82	2.50	2.000	.937	2.50	.750	1.250	.406	3/8-16	1.19	1.06	214	3/8-16X3.50
W12-16	W13-16	1.00	3.19	3.00	2.250	1.093	3.00	1.00	1.560	.469	7/16-14	1.38	1.38	219	7/16-14X4.00
W12-20	W13-20	1.25	3.75	3.50	2.625	1.250	3.50	1.25	1.750	.531	1/2-13	1.62	1.41	222	1/2-13X4.50
W12-24	W13-24	1.50	4.50	4.00	3.125	1.437	4.00	1.50	2.115	.656	5/8-11	1.88	1.75	225	5/8-11X5.00
W12-32	W13-32	2.00	5.25	5.00	3.812	1.75	5.00	1.94	2.490	.781	3/4-10	2.25	2.50	228	3/4-10X6.00

Mounting kit available on o-ring grooved flanges by simply adding suffix letter 'U' to part number.

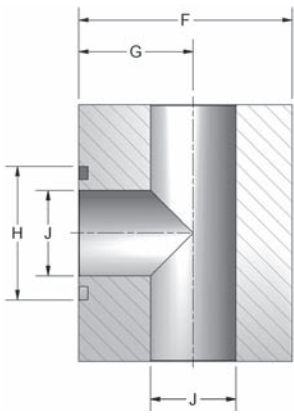

Figure 1

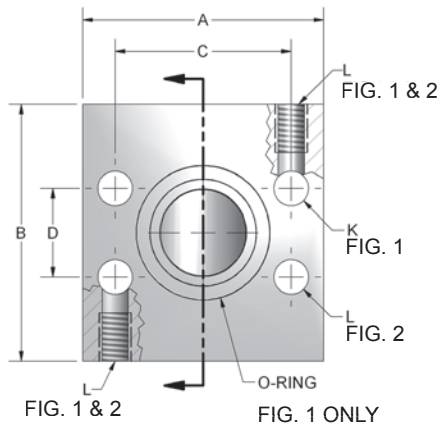

FIG. 1 ONLY

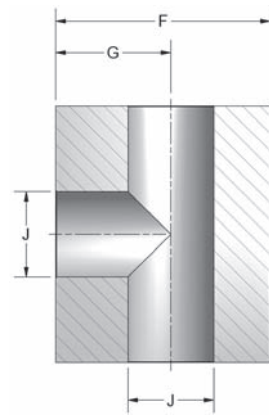

Figure 2

CODE 61 TEE JUNCTION BLOCK														
PART NO. O-RING FIG. 1	PART NO. FLAT FACE FIG. 2	PAD SIZE	A	B	C	D	F	G	H	J	K	L UNC-2B	MOUNTING HARDWARE	
													O-RING	SHCS
W17-12	W16-12	.75	2.62	2.75	1.875	.875	2.25	1.22	1.250	.75	.406	3/8-16	214	3/8-16X3.00
W17-16	W16-16	1.00	2.82	3.00	2.062	1.031	2.50	1.34	1.560	1.00	.406	3/8-16	219	3/8-16X3.25
W17-20	W16-20	1.25	3.19	3.50	2.312	1.188	3.00	1.56	1.750	1.25	.469	7/16-14	222	7/16-14X4.00
W17-24	W16-24	1.50	3.75	4.00	2.750	1.406	3.50	1.88	2.115	1.50	.531	1/2-13	225	1/2-13X4.50
W17-32	W16-32	2.00	4.00	4.25	3.062	1.688	4.00	2.09	2.490	2.00	.531	1/2-13	228	1/2-13X5.00

CODE 62 TEE JUNCTION BLOCK														
PART NO. O-RING FIG. 1	PART NO. FLAT FACE FIG. 2	PAD SIZE	A	B	C	D	F	G	H	J	K	L UNC-2B	MOUNTING HARDWARE	
													O-RING	SHCS
W19-12	W18-12	.75	2.81	3.00	2.00	.937	2.50	1.310	1.250	.750	.406	3/8-16	214	3/8-16X3.25
W19-16	W18-16	1.00	3.19	3.50	2.25	1.093	3.00	1.620	1.560	1.000	.492	7/16-14	219	7/16-14X4.00
W19-20	W18-20	1.25	3.75	4.00	2.625	1.250	3.50	1.880	1.750	1.250	.531	1/2-13	222	1/2-13X4.50
W19-24	W18-24	1.50	4.50	4.50	3.125	1.437	4.00	2.120	2.115	1.500	.656	5/8-11	225	5/8-11X5.00
W19-32	W18-32	2.00	5.25	5.00	3.812	1.750	5.00	2.750	2.490	1.940	.781	3/4-10	228	3/4-10X6.00

Mounting kit available on o-ring grooved flanges by simply adding suffix letter 'U' to part number.



FLOW, NEEDLE & CHECK VALVES

HYDRAULIC BALL VALVES

WELD COUPLINGS

FLANGES - CARBON STEEL

FLANGES - STAINLESS STEEL

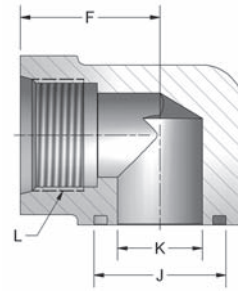
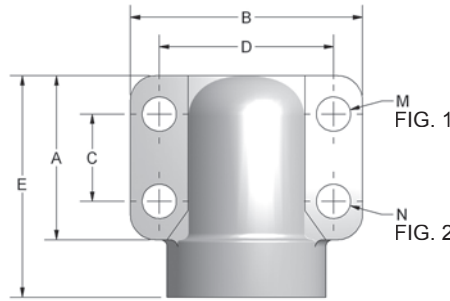
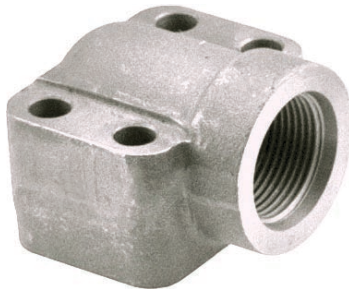

Figure 1

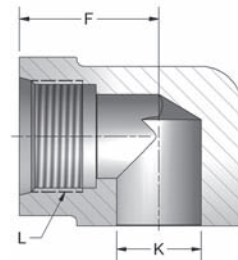
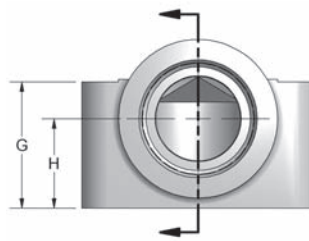

Figure 2

CODE 61 ELBOW SAE STRAIGHT THREAD

PART NO. O-RING FIG. 1	PART NO. FLAT FACE FIG. 2	PAD SIZE	A	B	C	D	E	F	G	H	J	K	L	M	N UNC-2B	MOUNTING HARDWARE	
																O-RING	SHCS
W164-12-12	W165-12-12	.75	1.69	2.56	.875	1.875	2.28	1.44	1.25	.875	1.250	.752	1-1/16-12	.406	3/8-16	214	3/8-16X2.00
W164-16-16	W165-16-16	1.00	1.94	2.75	1.031	2.062	2.62	1.66	1.50	1.062	1.560	1.002	1-5/16-12	.406	3/8-16	219	3/8-16X2.25
W164-20-20	W165-20-20	1.25	2.19	3.12	1.188	2.312	3.00	1.91	1.81	1.188	1.750	1.252	1-5/8-12	.469	7/16-14	222	7/16-14X2.75
W164-24-24	W165-24-24	1.50	2.56	3.69	1.406	2.750	3.33	2.05	2.00	1.312	2.115	1.502	1-7/8-12	.531	1/2-13	225	1/2-13X3.00
W164-32-32	W165-32-32	2.00	3.06	4.33	1.688	3.062	3.81	2.28	2.50	1.656	1.490	2.002	2-1/2-12	.531	1/2-13	228	1/2-13X3.50

CODE 61 ELBOW NPTF THREAD

PART NO. O-RING FIG. 1	PART NO. FLAT FACE FIG. 2	PAD SIZE	A	B	C	D	E	F	G	H	J	K	L	M	N UNC-2B	MOUNTING HARDWARE	
																O-RING	SHCS
W168-12-12	W170-12-12	.75	1.69	2.56	.875	1.875	2.28	1.44	1.25	.875	1.250	.752	.75	.406	3/8-16	214	3/8-16X2.00
W168-16-16	W170-16-16	1.00	1.94	2.75	1.031	2.062	2.62	1.66	1.50	1.062	1.560	1.002	1.00	.406	3/8-16	219	3/8-16X2.25
W168-20-20	W170-20-20	1.25	2.19	3.12	1.188	2.312	3.00	1.91	1.81	1.188	1.750	1.252	1.25	.469	7/16-14	222	7/16-14X2.75
W168-24-24	W170-24-24	1.50	2.56	3.69	1.406	2.750	3.33	2.05	2.00	1.312	2.115	1.502	1.50	.531	1/2-13	225	1/2-13X3.00
W168-32-32	W170-32-32	2.00	3.06	4.33	1.688	3.062	3.81	2.28	2.50	1.656	2.490	2.002	2.00	.531	1/2-13	228	1/2-13X3.50

CODE 62 ELBOW SAE STRAIGHT THREAD

PART NO. O-RING FIG. 1	PART NO. FLAT FACE FIG. 2	PAD SIZE	A	B	C	D	E	F	G	H	J	K	L	M	N UNC-2B	MOUNTING HARDWARE	
																O-RING	SHCS
W184-12-12	W185-12-12	.75	1.94	2.75	.937	2.000	2.62	1.66	1.50	1.062	1.250	.752	1-1/16-12	.406	3/8-16	214	3/8-16X2.25
W184-16-16	W185-16-16	1.00	2.19	3.12	1.093	2.250	3.00	1.91	1.81	1.188	1.560	1.002	1-5/16-12	.492	7/16-14	219	7/16-14X2.50
W184-20-20	W185-20-20	1.25	2.56	3.69	1.250	2.625	3.32	2.05	2.00	1.312	1.750	1.252	1-5/8-12	.531	1/2-13	222	1/2-13X3.00
W184-24-24	W185-24-24	1.50	3.06	4.33	1.437	3.125	3.81	2.28	2.50	1.656	2.115	1.502	1-7/8-12	.656	5/8-11	225	5/8-11X3.50

CODE 62 ELBOW NPTF THREAD

PART NO. O-RING FIG. 1	PART NO. FLAT FACE FIG. 2	PAD SIZE	A	B	C	D	E	F	G	H	J	K	L	M	N UNC-2B	MOUNTING HARDWARE	
																O-RING	SHCS
W188-12-12	W180-12-12	.75	1.94	2.75	.937	2.000	2.62	1.66	1.50	1.062	1.250	.752	.75	.406	3/8-16	214	3/8-16X2.25
W188-16-16	W180-16-16	1.00	2.19	3.12	1.093	2.250	3.00	1.91	1.81	1.188	1.560	1.002	1.00	.492	7/16-14	219	7/16-14X2.50
W188-20-20	W180-20-20	1.25	2.56	3.69	1.250	2.625	3.32	2.05	2.00	1.312	1.750	1.252	1.25	.531	1/2-13	222	1/2-13X3.00
W188-24-24	W180-24-24	1.50	3.06	4.33	1.437	3.125	3.81	2.28	2.50	1.656	2.115	1.502	1.50	.656	5/8-11	225	5/8-11X3.50

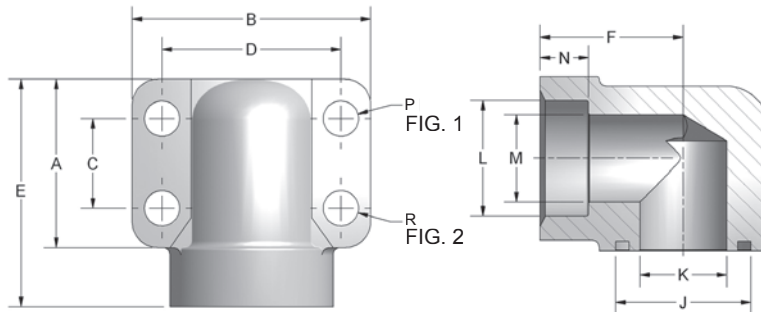

Figure 1

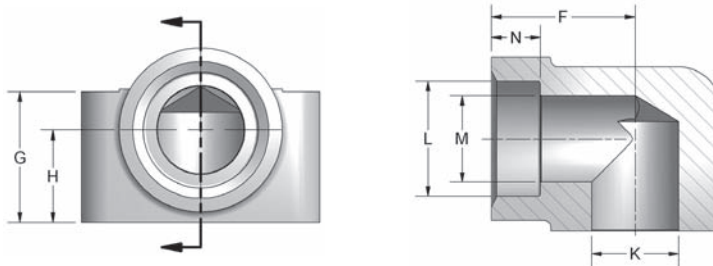
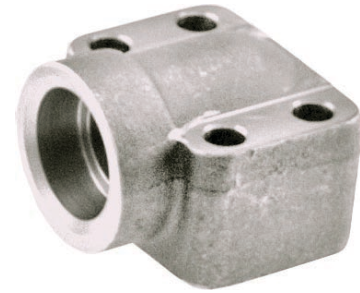

Figure 2

CODE 61 ELBOW SOCKET WELD - PIPE

PART NO. O-RING FIG. 1	PART NO. FLAT FACE FIG. 2	PAD SIZE	A	B	C	D	E	F	G	H	J	K	L	M	N	P	R UNC-2B	MOUNTING HARDWARE	
																		O-RING	SHCS
W176-12-12	W169-12-12	.75	1.69	2.56	.875	1.875	2.28	1.44	1.25	.875	1.250	.752	1.062	.75	.56	.406	3/8-16	214	3/8-16X2.00
W176-16-16	W169-16-16	1.00	1.94	2.75	1.031	2.062	2.62	1.66	1.50	1.062	1.560	1.002	1.328	1.00	.56	.406	3/8-16	219	3/8-16X2.25
W176-20-20	W169-20-20	1.25	2.19	3.12	1.188	2.312	3.00	1.91	1.81	1.188	1.750	1.252	1.672	1.25	.62	.469	7/16-14	222	7/16-14X2.75
W176-24-24	W169-24-24	1.50	2.56	3.69	1.406	2.750	3.33	2.05	2.00	1.312	2.115	1.502	1.922	1.50	.69	.531	1/2-13	225	1/2-13X3.00
W176-32-32	W169-32-32	2.00	3.06	4.33	1.688	3.062	3.81	2.28	2.50	1.656	2.490	2.002	2.406	2.00	.75	.531	1/2-13	228	1/2-13X3.50
W176-40-40	W169-40-40	2.50	3.56	5.00	2.000	3.500	4.66	2.88	2.78	1.900	2.995	2.502	2.906	2.50	.75	.531	1/2-13	232	1/2-13X5.00
W176-48-48	W169-48-48	3.00	4.00	5.50	2.438	4.188	5.00	3.00	3.35	2.400	3.615	3.002	3.547	3.00	.75	.656	5/8-11	237	5/8-11X6.00

CODE 62 ELBOW SOCKET WELD - PIPE

PART NO. O-RING FIG. 1	PART NO. FLAT FACE FIG. 2	PAD SIZE	A	B	C	D	E	F	G	H	J	K	L	M	N	P	R UNC-2B	MOUNTING HARDWARE	
																		O-RING	SHCS
W186-12-12	W189-12-12	.75	1.94	2.75	.937	2.000	2.62	1.66	1.50	1.062	1.250	.752	1.062	.75	.56	.406	3/8-16	214	3/8-16X2.25
W186-16-16	W189-16-16	1.00	2.19	3.12	1.093	2.250	3.00	1.91	1.81	1.188	1.560	1.002	1.328	1.00	.62	.492	7/16-14	219	7/16-14X2.50
W186-20-20	W189-20-20	1.25	2.56	3.69	1.250	2.625	3.32	2.05	2.00	1.312	1.750	1.252	1.672	1.25	.69	.531	1/2-13	222	1/2-13X3.00
W186-24-24	W189-24-24	1.50	3.06	4.33	1.437	3.125	3.81	2.28	2.50	1.656	2.115	1.502	1.922	1.50	.75	.656	5/8-11	225	5/8-11X3.50
W186-32-32	W189-32-32	2.00	3.56	5.00	1.750	3.812	4.66	2.88	2.69	1.900	2.490	2.002	2.406	2.00	.75	.781	3/4-10	228	3/4-10X4.50

Mounting kit available on o-ring grooved flanges by simply adding suffix letter 'U' to part number.

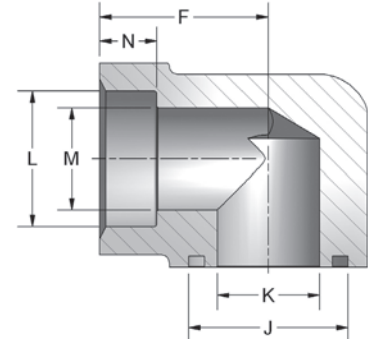
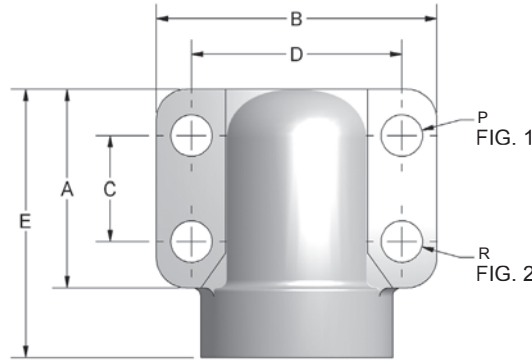

Figure 1

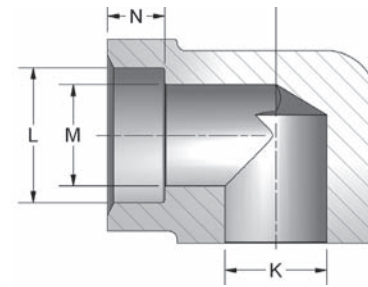
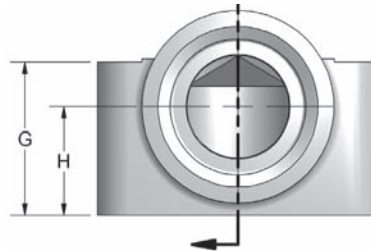

Figure 2

CODE 61 ELBOW SOCKET WELD - TUBE

PART NO. O-RING FIG. 1	PART NO. FLAT FACE FIG. 2	PAD SIZE	A	B	C	D	E	F	G	H	J	K	L	M	N	P	R UNC-2B	MOUNTING HARDWARE	
																		O-RING	SHCS
W172-12-12	W177-12-12	.75	1.69	2.56	.875	1.875	2.28	1.44	1.25	.875	1.250	.752	.752	.625	.312	.406	3/8-16	214	3/8-16X2.00
W172-16-12	W177-16-12	.75	1.69	2.56	.875	1.875	2.28	1.44	1.25	.875	1.250	.752	1.002	.750	.438	.406	3/8-16	214	3/8-16X2.00
W172-16-16	W177-16-16	1.00	1.94	2.75	1.031	2.062	2.62	1.66	1.50	1.062	1.560	1.002	1.002	.875	.438	.406	3/8-16	219	3/8-16X2.25
W172-20-16	W177-20-16	1.00	1.94	2.75	1.031	2.062	2.62	1.66	1.50	1.062	1.560	1.002	1.252	1.000	.500	.406	3/8-16	219	3/8-16X2.25
W172-20-20	W177-20-20	1.25	2.19	3.12	1.188	2.312	3.00	1.91	1.81	1.188	1.750	1.252	1.252	1.125	.500	.469	7/16-14	222	7/16-14X2.75
W172-24-20	W177-24-20	1.25	2.19	3.12	1.188	2.312	3.00	1.91	1.81	1.188	1.750	1.252	1.502	1.250	.562	.469	7/16-14	222	7/16-14X2.75
W172-24-24	W177-24-24	1.50	2.56	3.69	1.406	2.750	3.33	2.05	2.00	1.312	2.115	1.502	1.502	1.375	.562	.531	1/2-13	225	1/2-13X3.00
W172-28-24	W177-28-24	1.50	2.56	3.69	1.406	2.750	3.33	2.05	2.00	1.312	2.115	1.502	1.752	1.500	.562	.531	1/2-13	225	1/2-13X3.00
W172-32-32	W177-32-32	2.00	3.06	4.33	1.688	3.062	3.81	2.28	2.50	1.656	2.490	2.002	2.002	1.875	.625	.531	1/2-13	228	1/2-13X3.50
W172-36-32	W177-36-32	2.00	3.06	4.33	1.688	3.062	3.81	2.28	2.50	1.656	2.490	2.002	2.252	2.000	.625	.531	1/2-13	228	1/2-13X3.50

CODE 62 ELBOW SOCKET WELD - TUBE

PART NO. O-RING FIG. 1	PART NO. FLAT FACE FIG. 2	PAD SIZE	A	B	C	D	E	F	G	H	J	K	L	M	N	P	R UNC-2B	MOUNTING HARDWARE	
																		O-RING	SHCS
W182-12-12	W187-12-12	.75	1.94	2.75	.937	2.000	2.62	1.66	1.50	1.062	1.250	.752	.752	.625	.56	.406	3/8-16	214	3/8-16X2.25
W182-16-12	W187-16-12	.75	1.94	2.75	.937	2.000	2.62	1.66	1.50	1.062	1.250	.752	1.002	.750	.62	.406	3/8-16	214	3/8-16X2.25
W182-16-16	W187-16-16	1.00	2.19	3.12	1.093	2.250	3.00	1.91	1.81	1.188	1.560	1.002	1.002	.875	.62	.492	7/16-14	219	7/16-14X2.50
W182-20-16	W187-20-16	1.00	2.19	3.12	1.093	2.250	3.00	1.91	1.81	1.188	1.560	1.002	1.252	1.000	.69	.492	7/16-14	219	7/16-14X2.50
W182-20-20	W187-20-20	1.25	2.56	3.69	1.250	2.625	3.32	2.05	2.00	1.312	1.750	1.252	1.252	1.125	.69	.531	1/2-13	222	1/2-13X3.00
W182-24-20	W187-24-20	1.25	2.56	3.69	1.250	2.625	3.32	2.05	2.00	1.312	1.750	1.252	1.502	1.250	.75	.531	1/2-13	222	1/2-13X3.00
W182-24-24	W187-24-24	1.50	3.06	4.33	1.437	3.125	3.81	2.28	2.50	1.656	2.115	1.502	1.502	1.375	.75	.656	5/8-11	225	5/8-11X3.50

Mounting kit available on o-ring grooved flanges by simply adding suffix letter 'U' to part number.

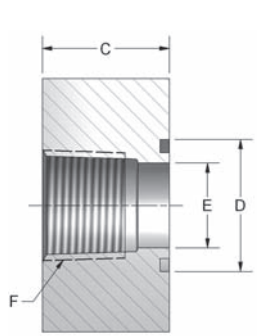

Figure 1

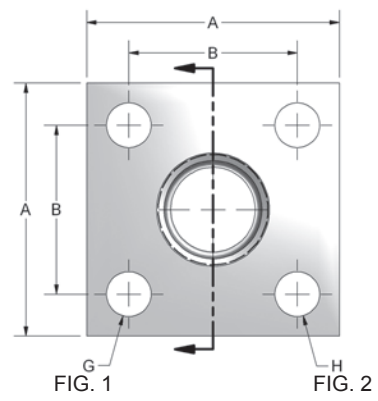

FIG. 1

FIG. 2

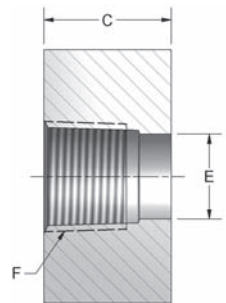

Figure 2



3000 SERIES SQUARE NPTF THREAD												
PART NO. O-RING FIG. 1	PART NO. FLAT FACE FIG. 2	PAD SIZE	A	B	C	D	E	F	G	H UNC-2B	MOUNTING HARDWARE	
											O-RING	SHCS
W65-12	W75-12	.75	2.25	1.438	1.25	1.250	.752	.75	.406	3/8-16	214	3/8-16X2.00
W65-16	W75-16	1.00	3.00	2.000	1.50	1.560	1.002	1.00	.531	1/2-13	219	1/2-13X2.25
W65-20	W75-20	1.25	3.00	2.000	1.50	1.750	1.252	1.25	.531	1/2-13	222	1/2-13X2.25
W65-24	W75-24	1.50	4.00	2.750	1.75	2.115	1.502	1.50	.656	5/8-11	225	5/8-11X2.75
W65-32	W75-32	2.00	4.00	2.750	1.75	2.490	2.002	2.00	.656	5/8-11	228	5/8-11X2.75
W65-40	W75-40	2.50	5.50	3.750	2.25	2.995	2.502	2.50	.906	7/8-9	232	7/8-9X3.50
W65-48	W75-48	3.00	5.50	3.750	2.25	3.615	3.002	3.00	.906	7/8-9	237	7/8-9X3.50

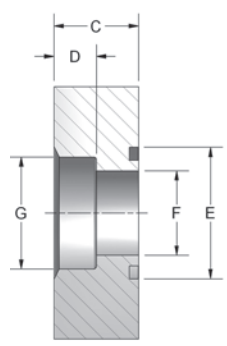

Figure 1

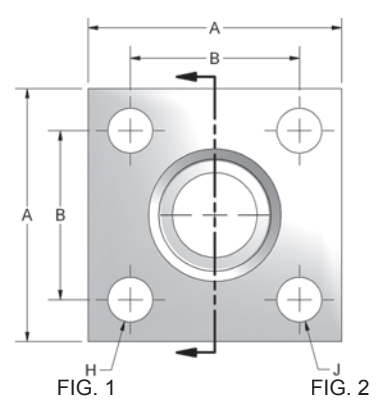

FIG. 1

FIG. 2

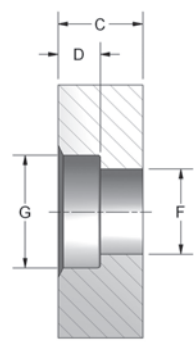

Figure 2



3000 SERIES SQUARE SOCKET WELD - PIPE													
PART NO. O-RING FIG. 1	PART NO. FLAT FACE FIG. 2	PAD SIZE	A	B	C	D	E	F	G	H	J UNC-2B	MOUNTING HARDWARE	
												O-RING	SHCS
W66-12	W76-12	.75	2.25	1.438	1.00	.50	1.250	.752	1.062	.406	3/8-16	214	3/8-16X1.75
W66-16	W76-16	1.00	3.00	2.000	1.00	.50	1.560	1.002	1.328	.531	1/2-13	219	1/2-13X1.75
W66-20	W76-20	1.25	3.00	2.000	1.00	.50	1.750	1.252	1.672	.531	1/2-13	222	1/2-13X1.75
W66-24	W76-24	1.50	4.00	2.750	1.25	.62	2.115	1.502	1.922	.656	5/8-11	225	5/8-11X2.25
W66-32	W76-32	2.00	4.00	2.750	1.25	.62	2.490	2.002	2.406	.656	5/8-11	228	5/8-11X2.25
W66-40	W76-40	2.50	5.50	3.750	1.50	.75	2.995	2.502	2.906	.906	7/8-9	232	7/8-9X2.75
W66-48	W76-48	3.00	5.50	3.750	1.50	.75	3.615	3.002	3.547	.906	7/8-9	237	7/8-9X2.75
W66-64	W76-64	4.00	7.00	5.000	2.00	.75	4.625	3.880	4.578	1.060	1-8	347	1-8X3.50

*HHCS provided on 7/8" size bolts and larger.

Mounting kit available on o-ring grooved flanges by simply adding suffix letter 'U' to part number.

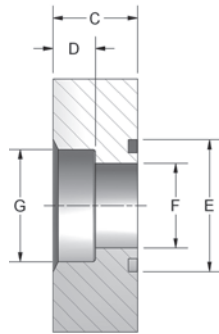

Figure 1

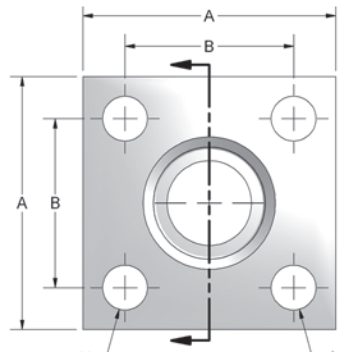

FIG. 1

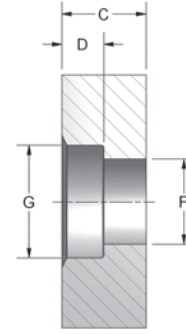

Figure 2

6000 SERIES SQUARE SOCKET WELD - PIPE													
PART NO. O-RING FIG. 1	PART NO. FLAT FACE FIG. 2	PIPE SIZE	A	B	C	D	E	F	G	H	J UNC-2B	MOUNTING HARDWARE	
												O-RING	SHCS
W56-40	W57-40	2.50	5.50	3.750	1.75	.75	2.995	2.12	2.911	.94	7/8-9	232	7/8-9X3.50
W56-48	W57-48	3.00	6.75	4.750	2.00	.75	3.615	2.62	3.540	1.06	1-8	236	1-8X4.00
W56-56	W57-56	3.50	8.00	5.500	2.40	1.002	3.990	3.00	4.045	1.31	1 1/4-7	342	1 1/4X5.00
W56-64	W57-64	4.00	8.50	6.000	2.40	1.002	4.490	3.44	4.550	1.31	1 1/4-7	346	1 1/4X5.00
W56-80	W57-80	5.00	10.00	7.250	2.90	1.002	5.365	4.31	5.625	1.56	1 1/2-6	353	1 1/2X6.00

*HHCS provided on 7/8" size bolts and larger.

Mounting kit available on o-ring grooved flanges by simply adding suffix letter 'U' to part number.



Lined area for notes

FLOW, NEEDLE & CHECK VALVES

HYDRAULIC BALL VALVES

WELD COUPLINGS

FLANGES - CARBON STEEL

FLANGES - STAINLESS STEEL

AFP Supplied 18-8(304) Stainless Steel Fastener Torque Requirements

CODE 61 SAE J518-1 / ISO 6162-1 Bolt Pattern		
Dash Size	Inch Size	Socket and Hex Head Fastener Torque Value
		18-8 UNC (lb-ft)
-8	1/2"	9
-12	3/4"	16
-16	1"	16
-20	1 1/4"	26
-24	1 1/2"	40
-32	2"	40
-40	2 1/2"	40
-48	3"	79
-56	3 1/2"	79
-64	4"	79
-80	5"	79

CODE 62 SAE J518-2 / ISO 6162-2 Bolt Pattern		
Dash Size	Inch Size	Socket and Hex Head Fastener Torque Value
		18-8 UNC (lb-ft)
-8	1/2"	9
-12	3/4"	16
-16	1"	26
-20	1 1/4"	40
-24	1 1/2"	79
-32	2"	140*

*-32 CODE 62 Hex Head torque value is 97 (lb-ft).

NOTE - All stainless steel fastener torque values were configured using regular grade Never-Seez® as lubricant. Use of another lubricant on fasteners can affect torque value. Consult factory for additional information.

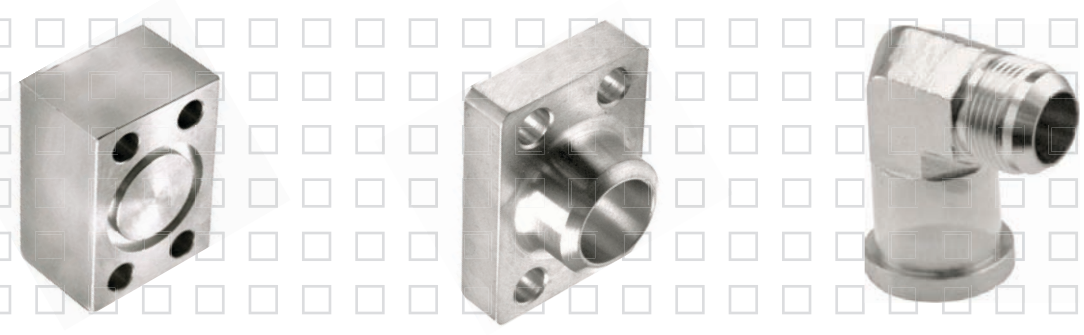

SAE J518 Split/Captive Flanges

For SAE Flanged Head Connection

CD 61 - CD 62 _____	106
CD 61 - CD 62 _____	107

SAE 4 Bolt Flanges

CD 61 - CD 62 Blanking _____	108
CD 61 - CD 62 NPTF _____	109
CD 61 - CD 62 SAE Thread _____	110
CD 61 - CD 62 Flat Socket _____	111
CD 61 - CD 62 Deep Socket Weld Pipe _____	112
CD 61 Butt Weld-Sched 40/Sched 80/Sched 160 _____	113
CD 62 Butt Weld-Sched 80/Sched 160/Sched XXS _____	114
CD 61 - CD 62 Elbow Socket Weld _____	115
CD 61 - CD 62 Elbow Block _____	116

Square 4 Bolt Flanges

3000 Series Flat Socket Weld _____	118
3000 Series NPTF Thread _____	118

Miscellaneous Components

CD 61 - CD 62 Tee Junction Block _____	117
--	-----

* The use of stainless steel fasteners may reduce the maximum working pressure of the assembly.

The standard grade of material for Anchor's stainless steel flanges is 316L. Other material grades are available upon request. In addition, material grades and flange dimensions may vary due to availability of raw material.



FLOW, NEEDLE & CHECK VALVES

HYDRAULIC BALL VALVES

WELD COUPLINGS

FLANGES - CARBON STEEL

FLANGES - STAINLESS STEEL

CODE 61 SPLIT FLANGE													
*PART NO.	**KIT PART NO.	FLANGE SIZE	A	B	C	D	E	F	G	H	J	MOUNTING HARDWARE	
												O-RING	HHCS
8SF-2-SS	8SFO-SS	.50	.86	2.12	1.500	.75	.50	1.219	.955	.245	.344	210	5/16-18X1.25
12SF-2-SS	12SFO-SS	.75	.98	2.56	1.875	.88	.56	1.531	1.265	.245	.406	214	3/8-16X1.25
16SF-2-SS	16SFO-SS	1.00	1.11	2.75	2.062	.94	.62	1.781	1.515	.295	.406	219	3/8-16X1.25
20SF-2-SS	20SFO-SS	1.25	1.39	3.12	2.312	.88	.56	2.031	1.720	.295	.469	222	7/16-14X1.50
24SF-2-SS	24SFO-SS	1.50	1.58	3.69	2.750	1.00	.62	2.406	2.000	.295	.531	225	1/2-13X1.50
32SF-2-SS	32SFO-SS	2.00	1.86	4.00	3.062	1.03	.62	2.844	2.470	.355	.531	228	1/2-13X1.50
40SF-2-SS	40SFO-SS	2.50	2.09	4.50	3.500	1.50	.75	3.344	2.950	.355	.531	232	1/2-13X1.75
48SF-2-SS	48SFO-SS	3.00	2.53	5.31	4.188	1.62	.88	4.031	3.580	.355	.656	237	5/8-11X1.75
56SF-2-SS	56SFO-SS	3.50	2.70	6.00	4.750	1.12	.88	4.531	4.030	.422	.656	241	5/8-11X2.00
64SF-2-SS	64SFO-SS	4.00	2.95	6.38	5.125	1.38	1.00	5.031	4.530	.422	.656	245	5/8-11X2.00

CODE 62 SPLIT FLANGE													
*PART NO.	**KIT PART NO.	FLANGE SIZE	A	B	C	D	E	F	G	H	J	MOUNTING HARDWARE	
												O-RING	HHCS
8SFX-2-SS	8SFXO-SS	.50	.89	2.22	1.594	.88	.62	1.281	.970	.285	.344	210	5/16-18X1.50
12SFX-2-SS	12SFXO-SS	.75	1.14	2.81	2.000	1.12	.75	1.656	1.280	.325	.406	214	3/8-16X1.50
16SFX-2-SS	16SFXO-SS	1.00	1.33	3.19	2.250	1.31	.94	1.906	1.530	.355	.469	219	7/16-14X1.75
20SFX-2-SS	20SFXO-SS	1.25	1.48	3.75	2.625	1.50	1.06	2.156	1.750	.385	.531	222	1/2-13X1.75
24SFX-2-SS	24SFXO-SS	1.50	1.83	4.44	3.125	1.69	1.19	2.531	2.030	.475	.656	225	5/8-11X2.25
32SFX-2-SS	32SFXO-SS	2.00	2.20	5.25	3.812	2.06	1.44	3.156	2.660	.475	.781	228	3/4-10X2.75

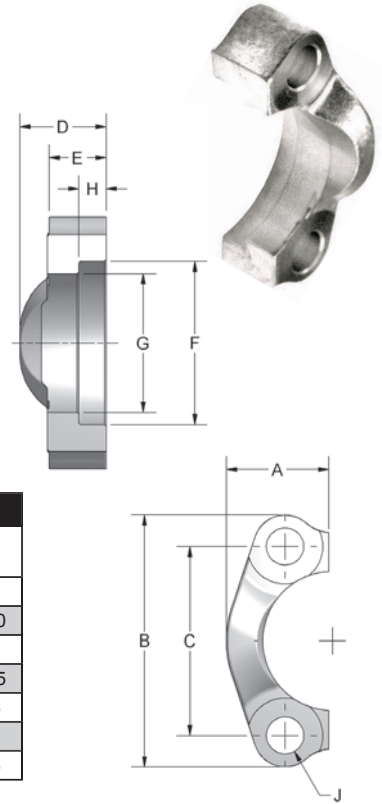

*Anchor part # includes: (1) split flange half only

**Kit part # includes: (2) split flange halves, (4) hex head bolts with lockwashers, and (1) Viton O-Ring

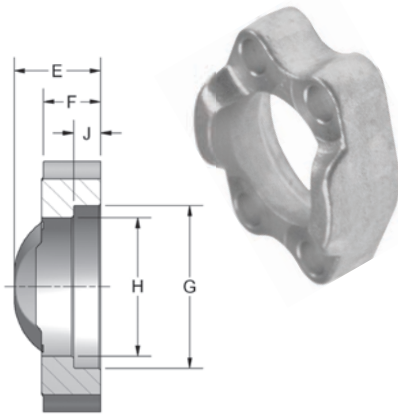

CODE 61 CAPTIVE FLANGE													
DRILLED	TAPPED	FLANGE SIZE	A	B	C	D	E	F	G	H	J	K	K UNC-2B
8SFW-SS	8SFTW-SS	.50	1.81	2.12	.688	1.500	.75	.50	1.219	.955	.245	.344	5/16-18
12SFW-SS	12SFTW-SS	.75	2.06	2.56	.875	1.875	.88	.56	1.531	1.265	.245	.406	3/8-16
16SFW-SS	16SFTW-SS	1.00	2.31	2.75	1.031	2.062	.94	.62	1.781	1.515	.295	.406	3/8-16
20SFW-SS	20SFTW-SS	1.25	2.88	3.12	1.188	2.312	.88	.56	2.031	1.720	.295	.469	7/16-14
24SFW-SS	24SFTW-SS	1.50	3.25	3.69	1.406	2.750	1.00	.62	2.406	2.000	.295	.531	1/2-13
32SFW-SS	32SFTW-SS	2.00	3.81	4.00	1.688	3.062	1.03	.62	2.844	2.470	.355	.531	1/2-13
40SFW-SS	40SFTW-SS	2.50	4.28	4.50	2.000	3.500	1.50	.75	3.344	2.950	.355	.531	1/2-13
48SFW-SS	48SFTW-SS	3.00	5.16	5.31	2.438	4.188	1.62	.88	4.031	3.580	.355	.656	5/8-11
56SFW-SS	56SFTW-SS	3.50	5.50	6.00	2.750	4.750	1.12	.88	4.531	4.030	.422	.656	5/8-11
64SFW-SS	64SFTW-SS	4.00	6.00	6.38	3.062	5.125	1.38	1.00	5.031	4.530	.422	.656	5/8-11

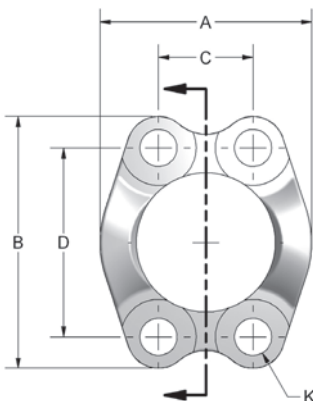

CODE 62 CAPTIVE FLANGE													
DRILLED	TAPPED	FLANGE SIZE	A	B	C	D	E	F	G	H	J	K	K UNC-2B
8SFXW-SS	8SFXTW-SS	.50	1.86	2.22	.718	1.594	.88	.62	1.281	.970	.285	.344	5/16-18
12SFXW-SS	12SFXTW-SS	.75	2.38	2.81	.937	2.000	1.12	.75	1.656	1.280	.325	.406	3/8-16
16SFXW-SS	16SFXTW-SS	1.00	2.75	3.19	1.093	2.250	1.31	.94	1.906	1.530	.355	.469	7/16-14
20SFXW-SS	20SFXTW-SS	1.25	3.06	3.75	1.250	2.625	1.50	1.06	2.156	1.750	.385	.531	1/2-13
24SFXW-SS	24SFXTW-SS	1.50	3.75	4.44	1.437	3.125	1.69	1.19	2.531	2.030	.475	.656	5/8-11
32SFXW-SS	32SFXTW-SS	2.00	4.50	5.25	1.750	3.812	2.06	1.44	3.156	2.660	.475	.781	3/4-10

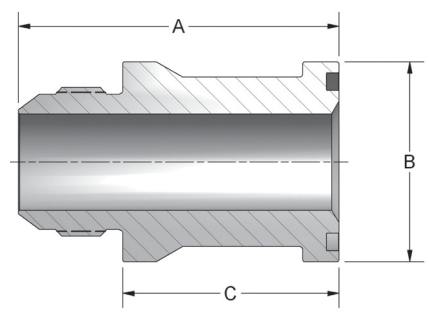

CODE 61 JIC THREAD						
PART NO.	TUBE O.D.	FLANGE SIZE	A	B	C	THREAD
300-8-8-SS	1/2	1/2	2.60	1.188	1.94	3/4-16
300-12-12-SS	3/4	3/4	2.75	1.500	1.89	1 1/16-12
300-16-16-SS	1	1	2.80	1.750	1.89	1 5/16-12
300-20-20-SS	1 1/4	1 1/4	2.80	2.000	1.84	1 5/8-12
300-24-24-SS	1 1/2	1 1/2	3.50	2.375	2.42	1 7/8-12

CODE 62 JIC THREAD						
PART NO.	TUBE O.D.	FLANGE SIZE	A	B	C	THREAD
600-12-12-SS	3/4	3/4	2.75	1.625	1.89	1 1/16-12
600-16-16-SS	1	1	2.80	1.875	1.89	1 5/16-12
600-20-20-SS	1 1/4	1 1/4	3.05	2.125	2.09	1 5/8-12
600-24-24-SS	1 1/2	1 1/2	3.50	2.500	2.42	1 7/8-12

For additional jump sizes, please consult factory.

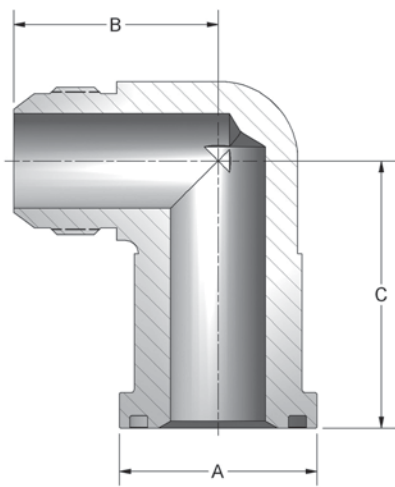

CODE 61 90 DEGREE JIC THREAD						
PART NO.	TUBE O.D.	FLANGE SIZE	A	B	C	THREAD
390-12-12-SS	3/4	3/4	1.500	1.66	2.13	1 1/16-12
390-16-16-SS	1	1	1.750	1.81	2.37	1 5/16-12
390-20-20-SS	1 1/4	1 1/4	2.000	2.06	2.62	1 5/8-12
390-24-24-SS	1 1/2	1 1/2	2.375	2.33	3.15	1 7/8-12

CODE 62 90 DEGREE JIC THREAD						
PART NO.	TUBE O.D.	FLANGE SIZE	A	B	C	THREAD
690-12-12-SS	3/4	3/4	1.625	1.66	2.13	1 1/16-12
690-16-16-SS	1	1	1.875	1.81	2.37	1 5/16-12
690-20-20-SS	1 1/4	1 1/4	2.125	2.06	2.76	1 5/8-12
690-24-24-SS	1 1/2	1 1/2	2.500	2.33	3.15	1 7/8-12

For additional jump sizes, please consult factory.

FLOW, NEEDLE & CHECK VALVES

HYDRAULIC BALL VALVES

WELD COUPLINGS

FLANGES - CARBON STEEL

FLANGES - STAINLESS STEEL

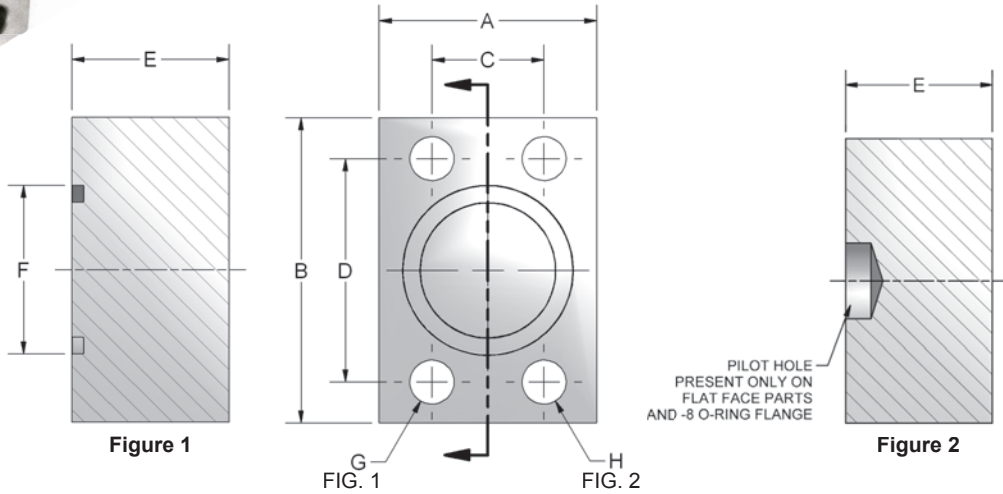

CODE 61 BLANKING												
PART NO. O-RING FIG. 1	PART NO. FLAT FACE FIG. 2	PAD	A	B	C	D	E	F	G	H UNC-2B	MOUNTING HARDWARE	
											O-RING	SHCS
W36-8-8-SS	W37-8-8-SS	.50	1.50	2.12	.688	1.50	1.20	1.000	.344	5/16-18	210	5/16-18X2.00
W36-12-12-SS	W37-12-12-SS	.75	1.75	2.62	.875	1.875	1.20	1.250	.406	3/8-16	214	3/8-16X2.00
W36-16-16-SS	W37-16-16-SS	1.00	2.00	2.82	1.031	2.063	1.45	1.560	.406	3/8-16	219	3/8-16X2.25
W36-20-20-SS	W37-20-20-SS	1.25	2.50	3.19	1.188	2.313	1.45	1.750	.469	7/16-14	222	7/16-14X2.25
W36-24-24-SS	W37-24-24-SS	1.50	2.75	3.75	1.406	2.750	1.70	2.115	.531	1/2-13	225	1/2-13X2.50
W36-32-32-SS	W37-32-32-SS	2.00	3.25	4.00	1.688	3.063	1.70	2.490	.531	1/2-13	228	1/2-13X2.50
W36-40-40-SS	W37-40-40-SS	2.50	4.00	4.50	2.000	3.500	1.95	2.995	.531	1/2-13	232	1/2-13X2.75
W36-48-48-SS	W37-48-48-SS	3.00	4.50	5.31	2.438	4.188	2.20	3.615	.656	5/8-11	237	5/8-11X3.50
W36-56-56-SS	W37-56-56-SS	3.50	5.00	6.00	2.750	4.750	1.45	4.095	.656	5/8-11	241	5/8-11X2.75
W36-64-64-SS	W37-64-64-SS	4.00	5.50	6.38	3.062	5.125	1.45	4.595	.656	5/8-11	245	5/8-11X2.75

CODE 62 BLANKING												
PART NO. O-RING FIG. 1	PART NO. FLAT FACE FIG. 2	PAD	A	B	C	D	E	F	G	H UNC-2B	MOUNTING HARDWARE	
											O-RING	SHCS
W38-8-8-SS	W39-8-8-SS	.50	1.75	2.22	.718	1.594	.94	1.000	.344	5/16-18	210	5/16-18X1.50
W38-12-12-SS	W39-12-12-SS	.75	2.00	2.81	.937	2.000	1.19	1.250	.406	3/8-16	214	3/8-16X2.00
W38-16-16-SS	W39-16-16-SS	1.00	2.25	3.19	1.093	2.250	1.44	1.560	.492	7/16-14	219	7/16-14X2.25
W38-20-20-SS	W39-20-20-SS	1.25	2.75	3.75	1.250	2.625	1.44	1.750	.531	1/2-13	222	1/2-13X2.50
W38-24-24-SS	W39-24-24-SS	1.50	3.25	4.50	1.437	3.125	1.69	2.115	.656	5/8-11	225	5/8-11X2.75
W38-32-32-SS	W39-32-32-SS	2.00	4.00	5.25	1.750	3.812	1.69	2.490	.781	3/4-10	228	3/4-10X3.00
W38-40-40-SS	W39-40-40-SS	2.50	5.00	6.88	2.312	4.875	1.94	2.995	.906	7/8-9	232	7/8-9X3.75
W38-48-48-SS	W39-48-48-SS	3.00	6.00	8.50	2.812	6.000	2.44	3.615	1.190	1 1/8-7	237	1 1/8-7X4.50

Mounting kit available on o-ring grooved flanges by simply adding suffix letter 'U' to part number.

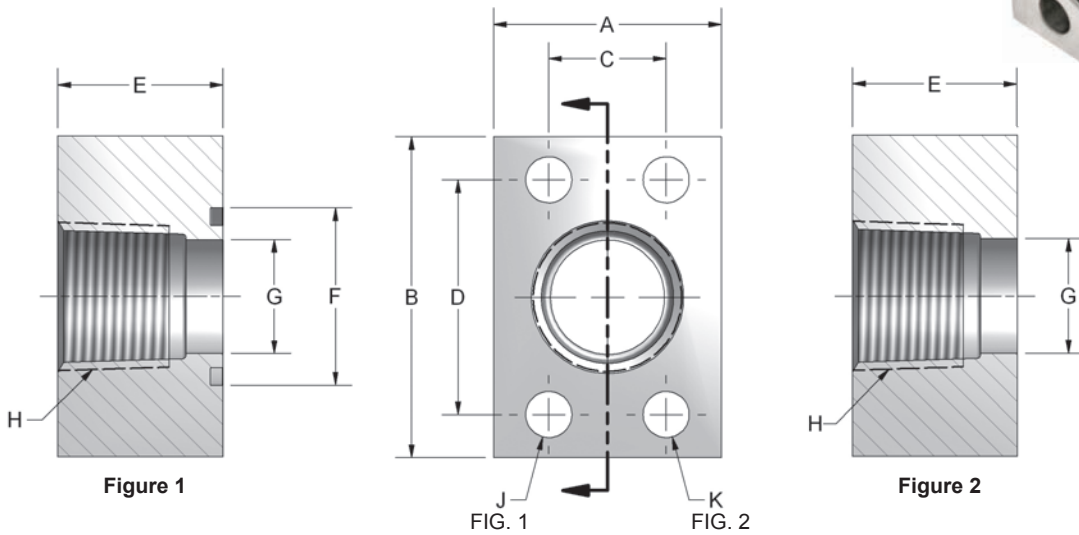

CODE 61 NPTF THREAD															
PART NO. O-RING FIG. 1	PART NO. FLAT FACE FIG. 2	PIPE SIZE	PAD SIZE	A	B	C	D	E	F	G	H	J	K UNC-2B	MOUNTING HARDWARE	
														O-RING	SHCS
W43-8-8-SS	W104-8-8-SS	.50	.50	1.50	2.12	.688	1.500	1.20	1.000	.502	.50	.344	5/16-18	210	5-16-18X1.75
W43-12-12-SS	W104-12-12-SS	.75	.75	1.75	2.62	.875	1.875	1.20	1.250	.752	.75	.406	3/8-16	214	3/8-16X2.00
W43-16-16-SS	W104-16-16-SS	1.00	1.00	2.00	2.82	1.031	2.062	1.45	1.560	1.002	1.00	.406	3/8-16	219	3/8-16X2.25
W43-20-20-SS	W104-20-20-SS	1.25	1.25	2.50	3.19	1.188	2.312	1.45	1.750	1.252	1.25	.469	7/16-14	222	7/16-14X2.25
W43-24-24-SS	W104-24-24-SS	1.50	1.50	2.75	3.75	1.406	2.750	1.70	2.115	1.502	1.50	.531	1/2-13	225	1/2-13X2.50
W43-32-32-SS	W104-32-32-SS	2.00	2.00	3.25	4.00	1.688	3.062	1.70	2.490	2.002	2.00	.531	1/2-13	228	1/2-13X2.50
W43-40-40-SS	W104-40-40-SS	2.50	2.50	4.00	4.50	2.000	3.500	1.95	2.995	2.502	2.50	.531	1/2-13	232	1/2-13X2.75
W43-48-48-SS	W104-48-48-SS	3.00	3.00	4.50	5.31	2.438	4.188	2.20	3.615	3.002	3.00	.656	5/8-11	237	5/8-11X3.00

CODE 62 NPTF THREAD															
PART NO. O-RING FIG. 1	PART NO. FLAT FACE FIG. 2	PIPE SIZE	PAD SIZE	A	B	C	D	E	F	G	H	J	K UNC-2B	MOUNTING HARDWARE	
														O-RING	SHCS
W44-8-8-SS	W45-8-8-SS	.50	.50	1.75	2.22	.718	1.594	.95	1.000	.502	.50	.344	5/16-18	210	5/16-18X1.50
W44-12-12-SS	W45-12-12-SS	.75	.75	2.00	2.81	.937	2.000	1.20	1.250	.752	.75	.406	3/8-16	214	3/8-16X2.00
W44-16-16-SS	W45-16-16-SS	1.00	1.00	2.25	3.19	1.093	2.250	1.45	1.560	1.002	1.00	.492	7/16-14	219	7/16-14X2.50
W44-20-20-SS	W45-20-20-SS	1.25	1.25	2.75	3.75	1.250	2.625	1.45	1.750	1.252	1.25	.531	1/2-13	222	1/2-13X2.25
W44-24-24-SS	W45-24-24-SS	1.50	1.50	3.25	4.50	1.437	3.125	1.70	2.115	1.502	1.50	.656	5/8-11	225	5/8-11X2.75
W44-32-32-SS	W45-32-32-SS	2.00	2.00	4.00	5.25	1.750	3.812	1.70	2.490	2.002	2.00	.781	3/4-10	228	3/4-10X3.00

Mounting kit available on o-ring grooved flanges by simply adding suffix letter 'U' to part number.

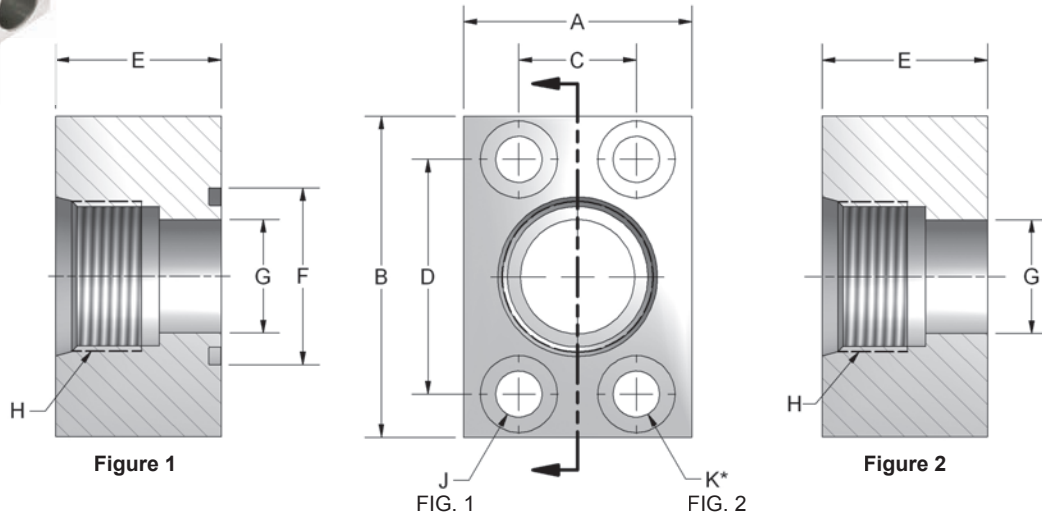

*No Counterbore

CODE 61 SAE STRAIGHT THREAD

PART NO. O-RING FIG. 1	PART NO. FLAT FACE FIG. 2	TUBE SIZE	PAD SIZE	A	B	C	D	E	F	G	H	J	K UNC-2B	MOUNTING HARDWARE	
														O-RING	SHCS
W46-8-8-SS	W106-8-8-SS	.50	.50	1.50	2.12	.688	1.500	1.20	1.000	.502	3/4-16	.344	5/16-18	210	5-16-18X1.25
W46-12-12-SS	W106-12-12-SS	.75	.75	1.75	2.62	.875	1.875	1.20	1.250	.752	1 1/16-12	.406	3/8-16	214	3/8-16X1.50
W46-16-16-SS	W106-16-16-SS	1.00	1.00	2.00	2.82	1.031	2.062	1.45	1.560	1.002	1 5/16-12	.406	3/8-16	219	3/8-16X1.50
W46-20-20-SS	W106-20-20-SS	1.25	1.25	2.50	3.19	1.188	2.312	1.45	1.750	1.252	1 5/8-12	.469	7/16-14	222	7/16-14X1.75
W46-24-24-SS	W106-24-24-SS	1.50	1.50	2.75	3.75	1.406	2.750	1.70	2.115	1.502	1 7/8-12	.531	1/2-13	225	1/2-13X2.00
*W46-32-32-SS	W106-32-32-SS	2.00	2.00	3.25	4.00	1.688	3.062	1.70	2.490	2.002	2 1/2-12	.531	1/2-13	228	1/2-13X2.00
**W46-40-40-SS	W106-40-40-SS	2.50	2.50	4.00	4.50	2.00	3.50	1.95	3.000	2.500	3-12	.530	1/2-13	232	1/2-13X2.25
**W46-48-48-SS	W106-48-48-SS	3.00	3.00	4.50	5.31	2.44	4.19	2.20	3.62	3.000	3 1/2-12	.660	5/8-11	237	5/8-11X2.25
**W46-64-64-SS	W106-64-64-SS	4.00	4.00	5.50	6.38	3.06	5.13	1.45	4.60	4.000	4 1/2-12	.660	5/8-11	245	5/8-11X1.50

*1000 PSI max for W46-32-32-SS

**Consult Factory For Working Pressure

CODE 62 SAE STRAIGHT THREAD

PART NO. O-RING FIG. 1	PART NO. FLAT FACE FIG. 2	TUBE SIZE	PAD SIZE	A	B	C	D	E	F	G	H	J	K UNC-2B	MOUNTING HARDWARE	
														O-RING	SHCS
W48-8-8-SS	W49-8-8-SS	.50	.50	1.75	2.22	.718	1.594	.95	1.000	.502	3/4-16	.344	5/16-18	210	5/16-18X1.25
W48-12-12-SS	W49-12-12-SS	.75	.75	2.00	2.81	.937	2.000	1.20	1.250	.752	1 1/16-12	.406	3/8-16	214	3/8-16X1.50
W48-16-16-SS	W49-16-16-SS	1.00	1.00	2.25	3.19	1.093	2.250	1.45	1.560	1.002	1 5/16-12	.492	7/16-14	219	7/16-14X1.75
W48-20-20-SS	W49-20-20-SS	1.25	1.25	2.75	3.75	1.250	2.625	1.45	1.750	1.252	1 5/8-12	.531	1/2-13	222	1/2-13X1.50
W48-24-24-SS	W49-24-24-SS	1.50	1.50	3.25	4.50	1.437	3.125	1.70	2.115	1.502	1 7/8-12	.656	5/8-11	225	5/8-11X2.00
W48-32-32-SS	W49-32-32-SS	2.00	2.00	4.00	5.25	1.750	3.812	1.70	2.490	2.002	2 1/2-12	.781	3/4-10	228	3/4-10X2.00

Mounting kit available on o-ring grooved flanges by simply adding suffix letter 'U' to part number.

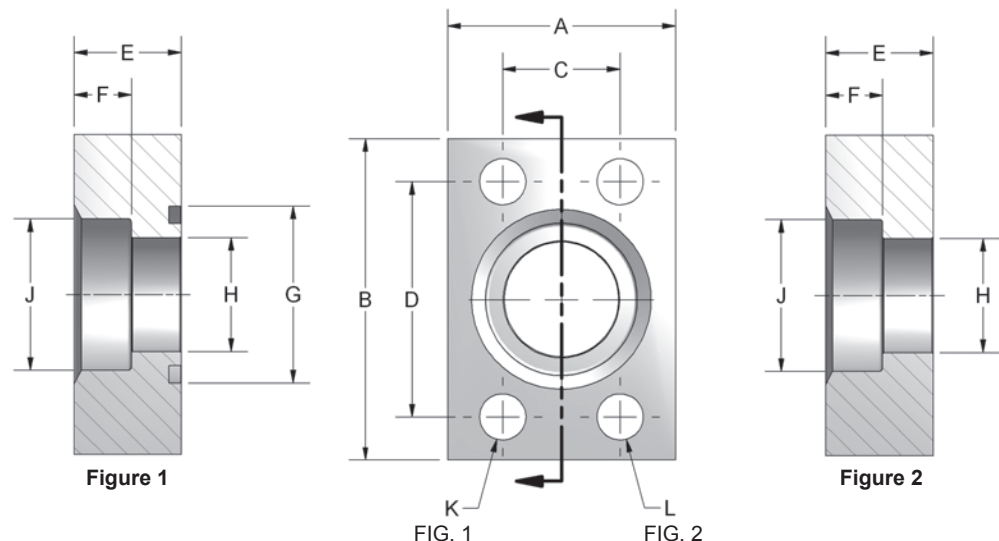

CODE 61 FLAT SOCKET WELD - PIPE

PART NO. O-RING FIG. 1	PART NO. FLAT FACE FIG. 2	PIPE SIZE	PAD SIZE	A	B	C	D	E	F	G	H	J	K	L UNC-2B	MOUNTING HARDWARE	
															O-RING	SHCS
W4-8-8-SS	W61-8-8-SS	.50	.50	1.50	2.12	.688	1.500	.69	.38	1.000	.502	.860	.344	5/16-18	210	5/16-18X1.25
W4-12-12-SS	W61-12-12-SS	.75	.75	1.75	2.62	.875	1.875	.94	.50	1.250	.752	1.070	.406	3/8-16	214	3/8-16X1.75
W4-16-16-SS	W61-16-16-SS	1.00	1.00	2.00	2.82	1.031	2.062	.94	.50	1.560	1.002	1.335	.406	3/8-16	219	3/8-16X1.75
W4-20-20-SS	W61-20-20-SS	1.25	1.25	2.50	3.19	1.188	2.312	.94	.50	1.750	1.252	1.680	.469	7/16-14	222	7/16-14X1.75
W4-24-24-SS	W61-24-24-SS	1.50	1.50	2.75	3.75	1.406	2.750	1.19	.50	2.115	1.502	1.920	.531	1/2-13	225	1/2-13X2.25
W4-32-32-SS	W61-32-32-SS	2.00	2.00	3.25	4.00	1.688	3.062	1.44	.62	2.490	2.002	2.411	.531	1/2-13	228	1/2-13X2.50
W4-40-40-SS	W61-40-40-SS	2.50	2.50	4.00	4.50	2.000	3.500	1.69	.75	2.995	2.502	2.911	.531	1/2-13	232	1/2-13X2.75
W4-48-48-SS	W61-48-48-SS	3.00	3.00	4.50	5.31	2.438	4.188	2.12	1.24	3.615	3.002	3.540	.656	5/8-11	237	5/8-11X3.50

CODE 62 FLAT SOCKET WELD - PIPE

PART NO. O-RING FIG. 1	PART NO. FLAT FACE FIG. 2	PIPE SIZE	PAD SIZE	A	B	C	D	E	F	G	H	J	K	L UNC-2B	MOUNTING HARDWARE	
															O-RING	SHCS
W59-8-8-SS	W60-8-8-SS	.50	.50	1.75	2.22	.718	1.594	.940	.50	1.000	.502	.860	.344	5/16-18	210	5/16-18X1.50
W59-12-12-SS	W60-12-12-SS	.75	.75	2.00	2.81	.937	2.000	.940	.50	1.250	.752	1.070	.406	3/8-16	214	3/8-16X1.75
W59-16-16-SS	W60-16-16-SS	1.00	1.00	2.25	3.19	1.093	2.250	.940	.50	1.560	1.002	1.335	.492	7/16-14	219	7/16-14X1.75
W59-20-20-SS	W60-20-20-SS	1.25	1.25	2.75	3.75	1.250	2.625	1.19	.50	1.750	1.252	1.672	.531	1/2-13	222	1/2-13X2.25
W59-24-24-SS	W60-24-24-SS	1.50	1.50	3.25	4.50	1.437	3.125	1.44	.50	2.115	1.502	1.920	.656	5/8-11	225	5/8-11X2.75
W59-32-32-SS	W60-32-32-SS	2.00	2.00	4.00	5.25	1.750	3.812	1.69	.62	2.490	2.002	2.411	.781	3/4-10	228	3/4-10X3.00
*W59-40-40-SS	*W60-40-40-SS	2.50	2.50	5.00	6.88	2.312	4.875	1.94	.62	2.995	2.502	2.911	.906	7/8-9	232	7/8-9X3.50
*W59-48-48-SS	*W60-48-48-SS	3.00	3.00	6.00	8.50	2.812	6.000	2.44	.62	3.615	3.002	3.540	1.190	1-1/8-7	237	1-1/8-7X4.50

*3000 PSI max working pressure

CODE 61 FLAT SOCKET WELD - PIPE - ALL SIZES 500 PSI

PART NO. O-RING FIG. 1	PART NO. FLAT FACE FIG. 2	PIPE SIZE	PAD SIZE	A	B	C	D	E	F	G	H	J	K	L UNC-2B	MOUNTING HARDWARE	
															O-RING	SHCS
W72-48-48-SS	W91-48-48-SS	3.00	3.00	4.50	5.31	2.438	4.188	1.38	1.13	3.615	3.002	3.540	.656	5/8-11	237	5/8-11X2.50
W72-56-56-SS	W91-56-56-SS	3.50	3.50	5.00	6.00	2.750	4.750	1.44	1.19	4.095	3.502	4.054	.656	5/8-11	241	5/8-11X2.50
W72-64-64-SS	W91-64-64-SS	4.00	4.00	5.50	6.38	3.062	5.125	1.450	1.20	4.595	4.002	4.550	.656	5/8-11	245	5/8-11X2.50

Mounting kit available on o-ring grooved flanges by simply adding suffix letter 'U' to part number.

FLOW, NEEDLE & CHECK VALVES



HYDRAULIC BALL VALVES

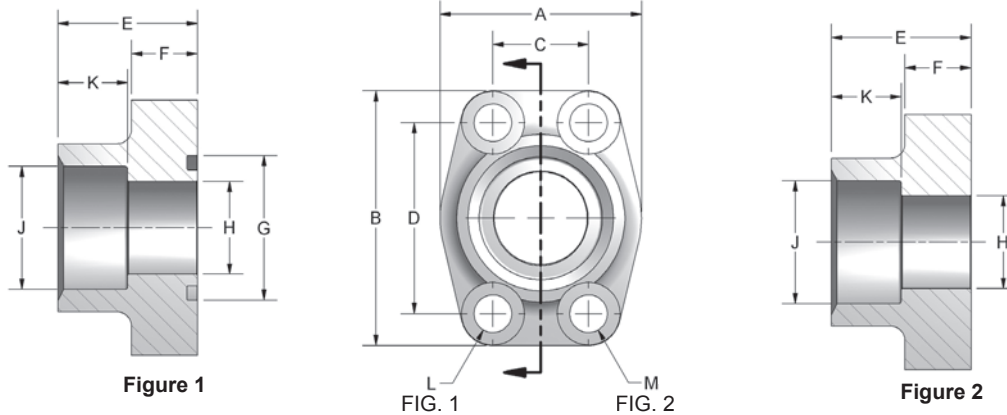

WELD COUPLINGS

FLANGES - CARBON STEEL

CODE 61 DEEP SOCKET WELD - PIPE

PART NO. O-RING FIG. 1	PART NO. FLAT FACE FIG. 2	PIPE SIZE	PAD SIZE	A	B	C	D	E	F	G	H	J	K	L	M UNC-2B	MOUNTING HARDWARE	
																O-RING	SHCS
W31-8-8-SS	W3-8-8-SS	.50	.50	1.81	2.13	.688	1.500	1.42	.63	1.000	.502	.855	.75	.344	5/16-18	210	5/16-18X1.25
W31-12-12-SS	W3-12-12-SS	.75	.75	1.97	2.56	.875	1.875	1.42	.71	1.250	.752	1.062	.75	.406	3/8-16	214	3/8-16X1.50
W31-16-16-SS	W3-16-16-SS	1.00	1.00	2.17	2.75	1.031	2.062	1.50	.71	1.560	1.002	1.328	.75	.406	3/8-16	219	3/8-16X1.50
W31-20-20-SS	W3-20-20-SS	1.25	1.25	2.68	3.12	1.188	2.312	1.61	.83	1.750	1.252	1.672	.87	.469	7/16-14	222	7/16-14X1.75
W31-24-24-SS	W3-24-24-SS	1.50	1.50	3.07	3.66	1.406	2.750	1.77	.98	2.115	1.502	1.922	.94	.531	1/2-13	225	1/2-13X1.75
W31-32-32-SS	W3-32-32-SS	2.00	2.00	3.54	4.00	1.688	3.062	1.77	.98	2.490	2.002	2.406	1.02	.531	1/2-13	228	1/2-13X1.75
W31-40-40-SS	W3-40-40-SS	2.50	2.50	4.09	4.49	2.000	3.500	1.97	.98	2.995	2.502	2.908	1.18	.531	1/2-13	232	1/2-13X1.75
W31-48-48-SS	W3-48-48-SS	3.00	3.00	4.88	5.28	2.438	4.188	1.97	1.06	3.615	3.002	3.547	1.34	.656	5/8-11	237	5/8-11X2.00

CODE 62 DEEP SOCKET WELD - PIPE

PART NO. O-RING FIG. 1	PART NO. FLAT FACE FIG. 2	PIPE SIZE	PAD SIZE	A	B	C	D	E	F	G	H	J	K	L	M UNC-2B	MOUNTING HARDWARE	
																O-RING	SHCS
W81-8-8-SS	W80-8-8-SS	.50	.50	1.81	2.21	.718	1.594	1.42	.63	1.000	.502	.855	.75	.344	5/16-18	210	5/16-18X1.25
W81-12-12-SS	W80-12-12-SS	.75	.75	2.17	2.80	.937	2.000	1.38	.83	1.250	.752	1.062	.87	.406	3/8-16	214	3/8-16X1.50
W81-16-16-SS	W80-16-16-SS	1.00	1.00	2.56	3.19	1.093	2.250	1.65	.98	1.560	1.002	1.328	.87	.492	7/16-14	219	7/16-14X1.75
W81-20-20-SS	W80-20-20-SS	1.25	1.25	3.07	3.75	1.250	2.625	1.77	1.06	1.750	1.252	1.672	.98	.531	1/2-13	222	1/2-13X1.75
W81-24-24-SS	W80-24-24-SS	1.50	1.50	3.70	4.41	1.437	3.125	1.97	1.18	2.115	1.502	1.922	1.10	.656	5/8-11	225	5/8-11X2.25
W81-32-32-SS	W80-32-32-SS	2.00	2.00	4.50	5.28	1.750	3.812	2.56	1.46	2.490	2.002	2.406	.94	.781	3/4-10	228	3/4-10X2.75

Mounting kit available on o-ring grooved flanges by simply adding suffix letter 'U' to part number.

FLANGES - STAINLESS STEEL

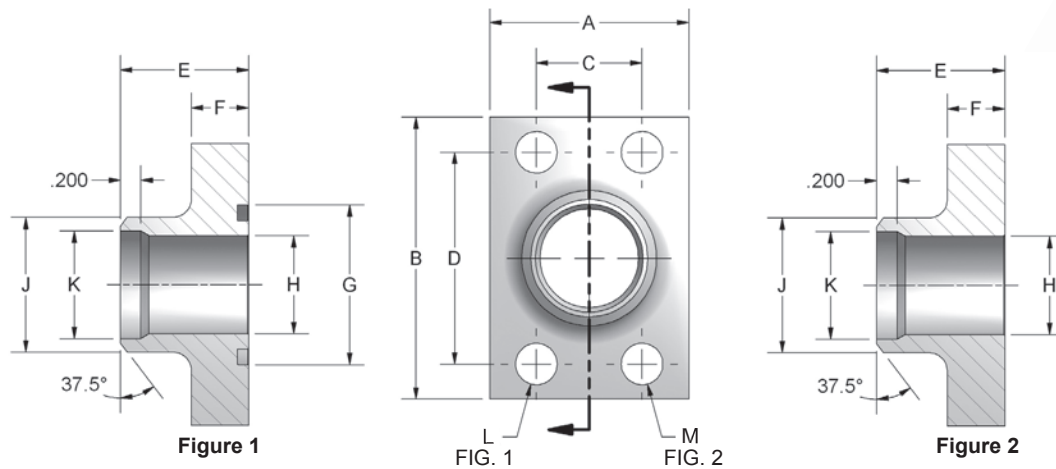

CODE 61 BUTT WELD - SCHEDULE 40 PIPE

PART NO. O-RING FIG. 1	PART NO. FLAT FACE FIG. 2	PIPE SIZE	PAD SIZE	A	B	C	D	E	F	G	H	J	K	L	M UNC-2B	MOUNTING HARDWARE	
																O-RING	SHCS
W35-8-SS	W34-8-SS	.50	.50	1.47	2.09	.688	1.500	1.06	.50	1.000	.548	.840	.624	.344	5/16-18	210	5/16-18X1.25
W35-12-SS	W34-12-SS	.75	.75	1.69	2.56	.875	1.875	1.06	.50	1.250	.744	1.050	.826	.406	3/8-16	214	3/8-16X1.25
W35-16-SS	W34-16-SS	1.00	1.00	1.94	2.75	1.031	2.062	1.25	.56	1.560	.959	1.315	1.051	.406	3/8-16	219	3/8-16X1.25
W35-20-SS	W34-20-SS	1.25	1.25	2.19	3.12	1.188	2.312	1.44	.62	1.750	1.280	1.660	1.382	.469	7/16-14	222	7/16-14X1.50
W35-24-SS	W34-24-SS	1.50	1.50	2.56	3.69	1.406	2.750	1.75	.81	2.115	1.502	1.900	1.612	.531	1/2-13	225	1/2-13X1.75
W35-32-SS	W34-32-SS	2.00	2.00	3.06	4.00	1.688	3.062	2.00	1.06	2.490	1.941	2.375	2.069	.531	1/2-13	228	1/2-13X2.00
W35-40-SS	W34-40-SS	2.50	2.50	3.56	4.50	2.000	3.500	2.31	1.12	2.995	2.325	2.875	2.471	.531	1/2-13	232	1/2-13X2.00
W35-48-SS	W34-48-SS	3.00	3.00	4.19	5.31	2.438	4.188	2.75	1.62	3.615	2.902	3.500	3.070	.656	5/8-11	237	5/8-11X2.75

CODE 61 BUTT WELD - SCHEDULE 80 PIPE

PART NO. O-RING FIG. 1	PART NO. FLAT FACE FIG. 2	PIPE SIZE	PAD SIZE	A	B	C	D	E	F	G	H	J	K	L	M UNC-2B	MOUNTING HARDWARE	
																O-RING	SHCS
W24-8-SS	W23-8-SS	.50	.50	1.50	2.12	.688	1.500	1.06	.50	1.000	.546	.840	SCHEDULE 40 ONLY	.344	5/16-18	210	5/16-18X1.25
W24-12-SS	W23-12-SS	.75	.75	1.69	2.56	.875	1.875	1.06	.50	1.250	.752	1.050		.406	3/8-16	214	3/8-16X1.25
W24-16-SS	W23-16-SS	1.00	1.00	1.94	2.75	1.031	2.062	1.25	.56	1.560	.959	1.315		.406	3/8-16	219	3/8-16X1.25
W24-20-SS	W23-20-SS	1.25	1.25	2.19	3.12	1.188	3.312	1.44	.62	1.750	1.280	1.660		.469	7/16-14	222	7/16-14X1.50
W24-24-SS	W23-24-SS	1.50	1.50	2.56	3.69	1.406	2.750	1.75	.81	2.115	1.502	1.900		.531	1/2-13	225	1/2-13X1.75
W24-32-SS	W23-32-SS	2.00	2.00	3.06	4.00	1.688	3.062	2.00	1.06	2.490	1.941	2.375		.531	1/2-13	228	1/2-13X2.00
W24-40-SS	W23-40-SS	2.50	2.50	3.56	4.50	2.000	3.500	2.31	1.12	2.995	2.325	2.875		.531	1/2-13	232	1/2-13X2.00
W24-48-SS	W23-48-SS	3.00	3.00	4.19	5.31	2.438	4.188	2.75	1.62	3.615	2.902	3.500		.656	5/8-11	237	5/8-11X2.75

CODE 61 BUTT WELD - SCHEDULE 160 PIPE

PART NO. O-RING FIG. 1	PART NO. FLAT FACE FIG. 2	PIPE SIZE	PAD SIZE	A	B	C	D	E	F	G	H	J	K	L	M UNC-2B	MOUNTING HARDWARE	
																O-RING	SHCS
W27-8-SS	W25-8-SS	.50	.50	1.50	2.12	.688	1.500	1.06	.50	1.000	.466	.840	SCHEDULE 40 ONLY	.344	5/16-18	210	5/16-18X1.25
W27-12-SS	W25-12-SS	.75	.75	1.69	2.56	.875	1.875	1.06	.50	1.250	.616	1.050		.406	3/8-16	214	3/8-16X1.25
W27-16-SS	W25-16-SS	1.00	1.00	1.94	2.75	1.031	2.062	1.25	.56	1.560	.817	1.315		.406	3/8-16	219	3/8-16X1.25
W27-20-SS	W25-20-SS	1.25	1.25	2.19	3.12	1.188	2.312	1.44	.62	1.750	1.162	1.660		.469	7/16-14	222	7/16-14X1.50
W27-24-SS	W25-24-SS	1.50	1.50	2.56	3.69	1.406	2.750	1.75	.81	2.115	1.339	1.900		.531	1/2-13	225	1/2-13X1.75
W27-32-SS	W25-32-SS	2.00	2.00	3.06	4.00	1.688	3.062	2.00	1.06	2.490	1.691	2.375		.531	1/2-13	228	1/2-13X2.00
W27-40-SS	W25-40-SS	2.50	2.50	3.56	4.50	2.000	3.500	2.31	1.12	2.995	2.127	2.875		.531	1/2-13	232	1/2-13X2.00
W27-48-SS	W25-48-SS	3.00	3.00	4.19	5.31	2.438	4.188	2.75	1.62	3.615	2.626	3.500		.656	5/8-11	237	5/8-11X2.75

Mounting kit available on o-ring grooved flanges by simply adding suffix letter 'U' to part number.

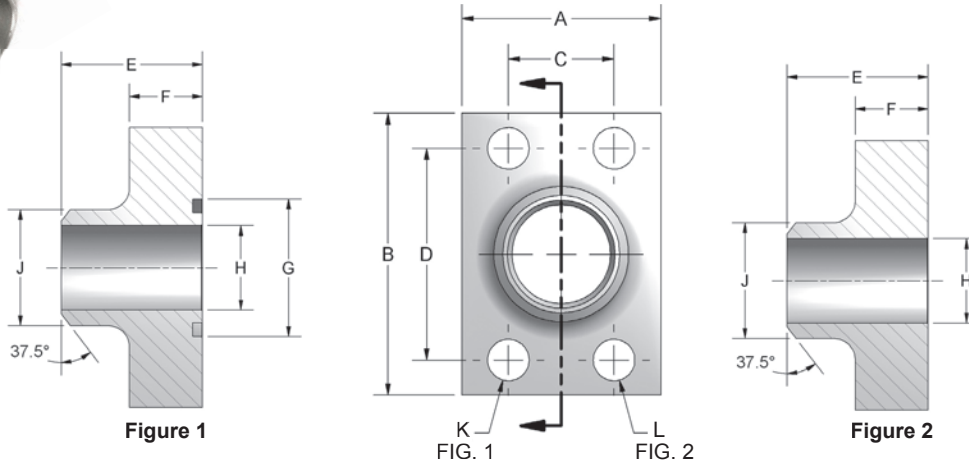
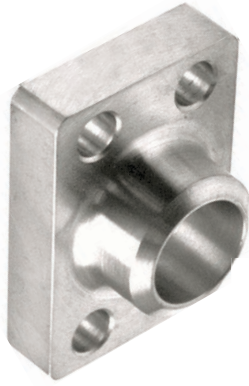

CODE 62 BUTT WELD - SCHEDULE 80 PIPE

PART NO. O-RING FIG. 1	PART NO. FLAT FACE FIG. 2	PIPE SIZE	PAD SIZE	A	B	C	D	E	F	G	H	J	K	L UNC-2B	MOUNTING HARDWARE	
															O-RING	SHCS
W28-12-SS	W26-12-SS	.75	.75	1.94	2.81	.937	2.000	1.42	.83	1.250	.744	1.050	.406	3/8-16	214	3/8-16X1.50
W28-16-SS	W26-16-SS	1.00	1.00	2.18	3.19	1.093	2.250	1.61	.83	1.560	.959	1.315	.492	7/16-14	219	7/16-14X1.50
W28-20-SS	W26-20-SS	1.25	1.25	2.44	3.75	1.250	2.625	1.73	.94	1.750	1.280	1.660	.531	1/2-13	222	1/2-13X2.00
W28-24-SS	W26-24-SS	1.50	1.50	2.81	4.44	1.437	3.125	2.17	1.10	2.115	1.502	1.900	.656	5/8-11	225	5/8-11X2.25
W28-32-SS	W26-32-SS	2.00	2.00	3.44	5.25	1.750	3.812	2.48	1.46	2.490	1.941	2.375	.781	3/4-10	228	3/4-10X3.00
*W28-40-SS	*W26-40-SS	2.50	2.50	5.00	6.88	2.312	4.875	2.37	1.50	2.995	2.325	2.875	.940	7/8-9	232	7/8-9X3.00
*W28-48-SS	*W26-48-SS	3.00	3.00	6.00	8.50	2.812	6.000	2.96	2.00	3.615	2.902	3.500	1.190	1-1/8-7	237	1-1/8-7X4.00

CODE 62 BUTT WELD - SCHEDULE 160 PIPE

PART NO. O-RING FIG. 1	PART NO. FLAT FACE FIG. 2	PIPE SIZE	PAD SIZE	A	B	C	D	E	F	G	H	J	K	L UNC-2B	MOUNTING HARDWARE	
															O-RING	SHCS
W30-12-SS	W29-12-SS	.75	.75	1.94	2.81	.937	2.000	1.42	.83	1.250	.616	1.050	.406	3/8-16	214	3/8-16X1.50
W30-16-SS	W29-16-SS	1.00	1.00	2.18	3.19	1.093	2.250	1.61	.83	1.560	.817	1.315	.492	7/16-14	219	7/16-14X1.50
W30-20-SS	W29-20-SS	1.25	1.25	2.44	3.75	1.250	2.625	1.73	.94	1.750	1.162	1.660	.531	1/2-13	222	1/2-13X2.00
W30-24-SS	W29-24-SS	1.50	1.50	2.81	4.44	1.437	3.125	2.17	1.10	2.115	1.339	1.900	.656	5/8-11	225	5/8-11X2.25
W30-32-SS	W29-32-SS	2.00	2.00	3.44	5.25	1.750	3.812	2.48	1.46	2.490	1.691	2.375	.781	3/4-10	228	3/4-10X3.00
*W30-40-SS	*W29-40-SS	2.50	2.50	5.00	6.88	2.312	4.875	2.37	1.50	2.995	2.127	2.875	.940	7/8-9	232	7/8-9X3.00
*W30-48-SS	*W29-48-SS	3.00	3.00	6.00	8.50	2.812	6.000	2.96	2.00	3.615	2.626	3.500	1.190	1-1/8-7	237	1-1/8-7X4.00

CODE 62 BUTT WELD - SCHEDULE XXS PIPE

PART NO. O-RING FIG. 1	PART NO. FLAT FACE FIG. 2	PIPE SIZE	PAD SIZE	A	B	C	D	E	F	G	H	J	K	L UNC-2B	MOUNTING HARDWARE	
															O-RING	SHCS
W33-12-SS	W32-12-SS	.75	.75	1.94	2.81	.937	2.000	1.42	.83	1.250	.436	1.050	.406	3/8-16	214	3/8-16X1.50
W33-16-SS	W32-16-SS	1.00	1.00	2.18	3.19	1.093	2.250	1.61	.83	1.560	.601	1.315	.492	7/16-14	219	7/16-14X1.50
W33-20-SS	W32-20-SS	1.25	1.25	2.44	3.75	1.250	2.625	1.73	.94	1.750	.898	1.660	.531	1/2-13	222	1/2-13X2.00
W33-24-SS	W32-24-SS	1.50	1.50	2.81	4.44	1.437	3.125	2.17	1.10	2.115	1.102	1.900	.656	5/8-11	225	5/8-11X2.25
W33-32-SS	W32-32-SS	2.00	2.00	3.44	5.25	1.750	3.812	2.48	1.46	2.490	1.505	2.375	.781	3/4-10	228	3/4-10X3.00
*W33-40-SS	*W32-40-SS	2.50	2.50	5.00	6.88	2.312	4.875	2.37	1.50	2.995	1.773	2.875	.940	7/8-9	232	7/8-9X3.00
*W33-48-SS	*W32-48-SS	3.00	3.00	6.00	8.50	2.812	6.000	2.96	2.00	3.615	2.302	3.500	1.190	1-1/8-7	237	1-1/8-7X4.00

*3000 PSI Max Working Pressure

Mounting kit available on o-ring grooved flanges by simply adding suffix letter 'U' to part number.



FLOW, NEEDLE & CHECK VALVES

HYDRAULIC BALL VALVES

WELD COUPLINGS

FLANGES - CARBON STEEL

FLANGES - STAINLESS STEEL

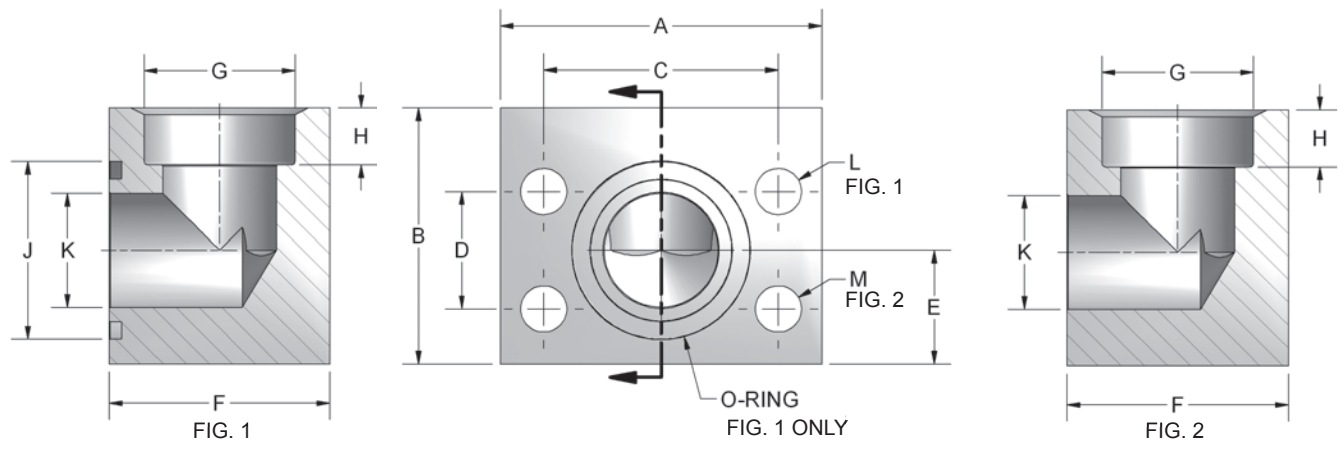

CODE 61 ELBOW SOCKET WELD - PIPE

PART NO. O-RING FIG. 1	PART NO. FLAT FACE FIG. 2	PIPE SIZE	PAD SIZE	A	B	C	D	E	F	G	H	J	K	L	M UNC-2B	MOUNTING HARDWARE	
																O-RING	SHCS
W176-8-8-SS	W169-8-8-SS	.50	.50	2.12	1.75	1.500	.688	.75	1.44	.855	.380	1.000	.50	.344	5/16-18	210	5/16-18X2.00
W176-12-12-SS	W169-12-12-SS	.75	.75	2.62	2.00	1.875	.875	.88	1.70	1.062	.500	1.250	.75	.406	3/8-16	214	3/8-16X2.50
W176-16-16-SS	W169-16-16-SS	1.00	1.00	2.82	2.25	2.062	1.031	1.00	1.94	1.328	.500	1.560	1.00	.406	3/8-16	219	3/8-16X2.75
W176-20-20-SS	W169-20-20-SS	1.25	1.25	3.19	2.75	2.312	1.188	1.25	2.40	1.672	.500	1.750	1.25	.469	7/16-14	222	7/16-14X3.00
W176-24-24-SS	W169-24-24-SS	1.50	1.50	3.75	3.00	2.750	1.406	1.38	2.90	1.922	.500	2.115	1.50	.531	1/2-13	225	1/2-13X4.00
W176-32-32-SS	W169-32-32-SS	2.00	2.00	4.00	3.50	3.062	1.688	1.62	3.40	2.406	.500	2.490	2.00	.531	1/2-13	228	1/2-13X4.50
W176-40-40-SS	W169-40-40-SS	2.50	2.50	4.50	4.00	3.500	2.000	2.00	3.96	2.906	.500	2.995	2.50	.531	1/2-13	232	1/2-13X5.00
W176-48-48-SS	W169-48-48-SS	3.00	3.00	5.31	5.00	4.188	2.438	2.25	4.96	3.547	.625	3.615	3.00	.656	5/8-11	237	5/8-11X6.00

CODE 62 ELBOW SOCKET WELD - PIPE

PART NO. O-RING FIG. 1	PART NO. FLAT FACE FIG. 2	PIPE SIZE	PAD SIZE	A	B	C	D	E	F	G	H	J	K	L	M UNC-2B	MOUNTING HARDWARE	
																O-RING	SHCS
W186-8-8-SS	W189-8-8-SS	.50	.50	2.22	2.00	1.594	.718	.88	1.46	.860	.380	1.000	.50	.344	5/16-18	210	5/16-18X2.25
W186-12-12-SS	W189-12-12-SS	.75	.75	2.81	2.25	2.000	.937	1.00	1.70	1.062	.500	1.250	.75	.406	3/8-16	214	3/8-16X2.50
W186-16-16-SS	W189-16-16-SS	1.00	1.00	3.19	2.50	2.250	1.093	1.12	2.21	1.328	.500	1.560	1.00	.492	7/16-14	219	7/16-14X3.25
W186-20-20-SS	W189-20-20-SS	1.25	1.25	3.75	3.00	2.625	1.250	1.38	2.44	1.672	.500	1.750	1.25	.531	1/2-13	222	1/2-13X3.25
W186-24-24-SS	W189-24-24-SS	1.50	1.50	4.50	3.50	3.125	1.437	1.62	2.96	1.922	.500	2.115	1.50	.656	5/8-11	225	5/8-11X4.25
W186-32-32-SS	W189-32-32-SS	2.00	2.00	5.25	4.00	3.812	1.750	2.00	3.46	2.406	.500	2.490	2.00	.781	3/4-10	228	3/4-10X5.00

Mounting kit available on o-ring grooved flanges by simply adding suffix letter 'U' to part number.

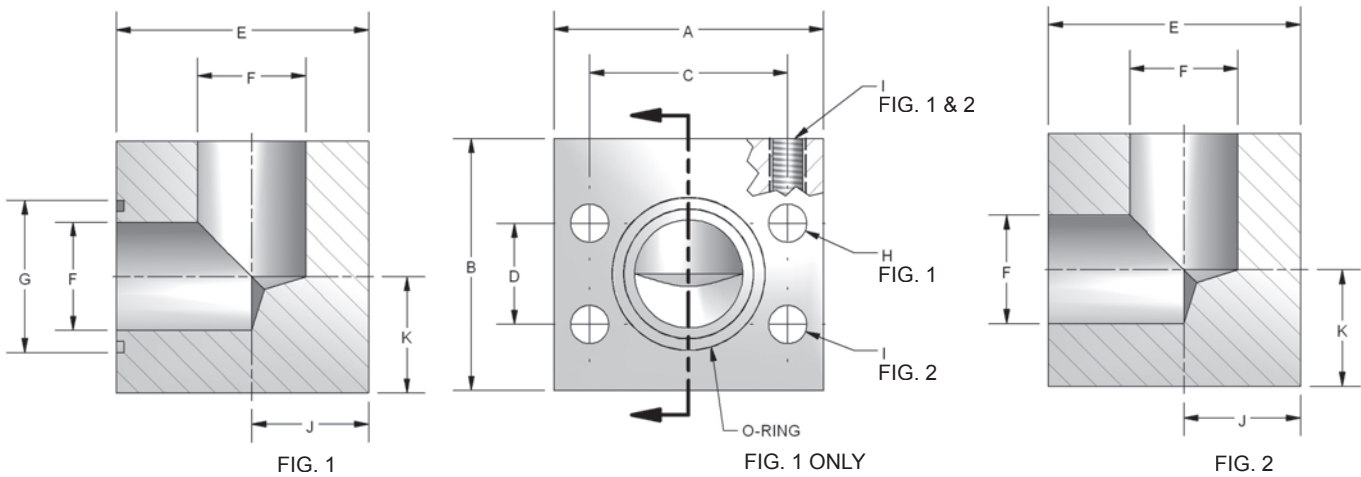

CODE 61 ELBOW BLOCK

PART NO. O-RING FIG. 1	PART NO. FLAT FACE FIG. 2	PAD SIZE	A	B	C	D	E	F	G	H	I UNC-2B	J	K	MOUNTING HARDWARE	
														O-RING	SHCS
W14-12-SS	W15-12-SS	.75	2.62	2.50	1.875	.875	2.25	.75	1.250	.406	3/8-16	1.03	1.03	214	3/8-16X3.00
W14-16-SS	W15-16-SS	1.00	2.82	2.50	2.062	1.031	2.50	1.00	1.560	.406	3/8-16	1.16	1.09	219	3/8-16X3.25
W14-20-SS	W15-20-SS	1.25	3.19	3.00	2.312	1.188	3.00	1.25	1.750	.469	7/16-14	1.44	1.31	222	7/16-14X4.00
W14-24-SS	W15-24-SS	1.50	3.75	3.50	2.750	1.406	3.50	1.50	2.115	.531	1/2-13	1.62	1.62	225	1/2-13X4.50
W14-32-SS	W15-32-SS	2.00	4.00	4.00	3.062	1.688	4.00	2.490	2.490	.531	1/2-13	1.91	2.28	228	1/2-13X5.00

CODE 62 ELBOW BLOCK

PART NO. O-RING FIG. 1	PART NO. FLAT FACE FIG. 2	PAD SIZE	A	B	C	D	E	F	G	H	I UNC-2B	J	K	MOUNTING HARDWARE	
														O-RING	SHCS
W12-12-SS	W13-12-SS	.75	2.82	2.50	2.000	.937	2.50	.750	1.250	.406	3/8-16	1.19	1.06	214	3/8-16X3.50
W12-16-SS	W13-16-SS	1.00	3.19	3.00	2.250	1.093	3.00	1.00	1.560	.469	7/16-14	1.38	1.38	219	7/16-14X4.00
W12-20-SS	W13-20-SS	1.25	3.75	3.50	2.625	1.250	3.50	1.25	1.750	.531	1/2-13	1.62	1.41	222	1/2-13X4.50
W12-24-SS	W13-24-SS	1.50	4.50	4.00	3.125	1.437	4.00	1.50	2.115	.656	5/8-11	1.88	1.75	225	5/8-11X5.00
W12-32-SS	W13-32-SS	2.00	5.25	5.00	3.812	1.75	5.00	1.940	2.490	.781	3/4-10	2.25	2.50	228	3/4-10X6.00

Mounting kit available on o-ring grooved flanges by simply adding suffix letter 'U' to part number.

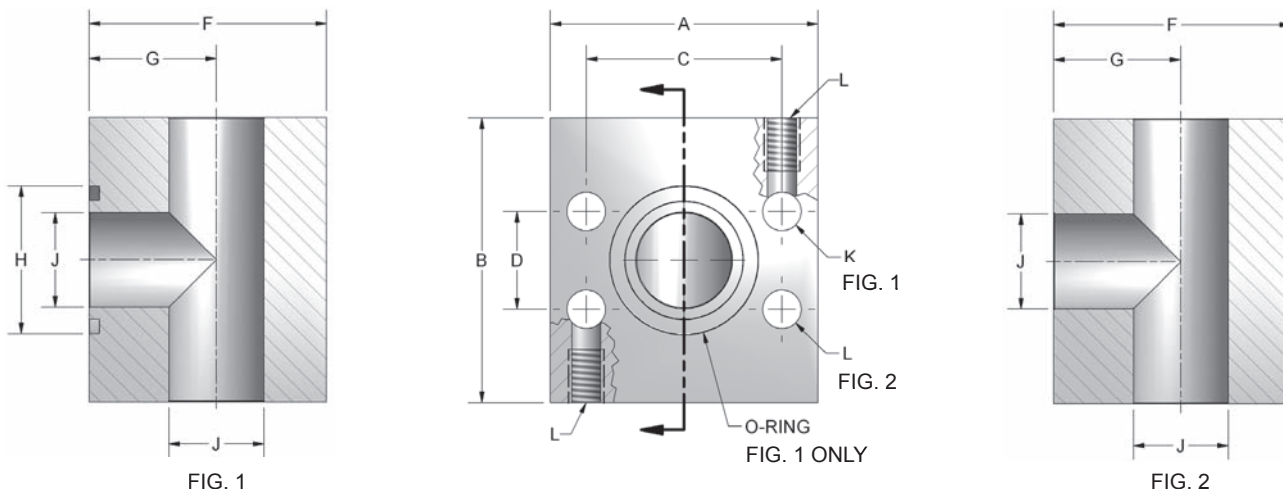

CODE 61 TEE JUNCTION BLOCK															
PART NO. O-RING FIG. 1	PART NO. FLAT FACE FIG. 2	PAD SIZE	A	B	C	D	E	F	G	H	J	K	L UNC-2B	MOUNTING HARDWARE	
														O-RING	SHCS
W17-12-SS	W16-12-SS	.75	2.62	2.75	1.875	.875	1.38	2.25	1.22	1.250	.75	.406	3/8-16	214	3/8-16X3.00
W17-16-SS	W16-16-SS	1.00	2.82	3.00	2.062	1.031	1.50	2.50	1.34	1.560	1.00	.406	3/8-16	219	3/8-16X3.25
W17-20-SS	W16-20-SS	1.25	3.19	3.50	2.312	1.188	1.75	3.00	1.56	1.750	1.25	.492	7/16-14	222	7/16-14X4.00
W17-24-SS	W16-24-SS	1.50	3.75	4.00	2.750	1.406	2.00	3.50	1.88	2.115	1.50	.531	1/2-13	225	1/2-13X4.50
W17-32-SS	W16-32-SS	2.00	4.00	4.25	3.062	1.688	2.12	4.00	2.09	2.490	2.00	.531	1/2-13	228	1/2-13X5.00

CODE 62 TEE JUNCTION BLOCK															
PART NO. O-RING FIG. 1	PART NO. FLAT FACE FIG. 2	PAD SIZE	A	B	C	D	E	F	G	H	J	K	L UNC-2B	MOUNTING HARDWARE	
														O-RING	SHCS
W19-12-SS	W18-12-SS	.75	2.81	3.00	2.000	.937	1.50	2.50	1.310	1.250	.750	.406	3/8-16	214	3/8-16X3.25
W19-16-SS	W18-16-SS	1.00	3.19	3.50	2.250	1.093	1.75	3.00	1.620	1.560	1.000	.492	7/16-14	219	7/16-14X4.00
W19-20-SS	W18-20-SS	1.25	3.75	4.00	2.625	1.250	2.00	3.50	1.880	1.750	1.250	.531	1/2-13	222	1/2-13X4.50
W19-24-SS	W18-24-SS	1.50	4.50	4.50	3.125	1.437	2.25	4.00	2.120	2.115	1.500	.656	5/8-11	225	5/8-11X5.00
W19-32-SS	W18-32-SS	2.00	5.25	5.00	3.812	1.750	2.50	5.00	2.750	2.490	1.940	.781	3/4-10	228	3/4-10X6.00

Mounting kit available on o-ring grooved flanges by simply adding suffix letter 'U' to part number.

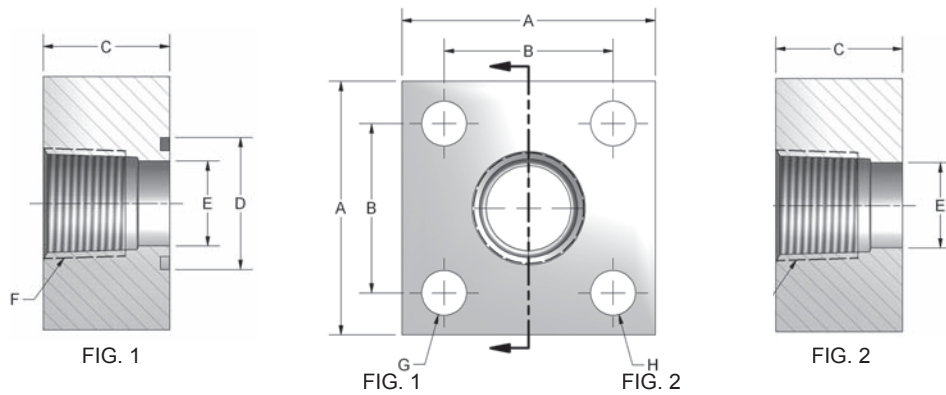

3000 SERIES SQUARE NPTF THREAD												
PART NO. O-RING FIG. 1	PART NO. FLAT FACE FIG. 2	PIPE SIZE	A	B	C	D	E	F	G	H UNC-2B	MOUNTING HARDWARE	
											O-RING	SHCS
W65-12-SS	W75-12-SS	.75	2.25	1.438	1.25	1.375	.752	.75	.406	3/8-16	216	3/8-16X2.00
W65-16-SS	W75-16-SS	1.00	3.00	2.000	1.50	1.750	1.002	1.00	.531	1/2-13	222	1/2-13X2.25
W65-20-SS	W75-20-SS	1.25	3.00	2.000	1.50	1.750	1.252	1.25	.531	1/2-13	222	1/2-13X2.25
W65-24-SS	W75-24-SS	1.50	4.00	2.750	1.75	2.500	1.502	1.50	.656	5/8-11	228	5/8-11X2.75
W65-32-SS	W75-32-SS	2.00	4.00	2.750	1.75	2.500	2.002	2.00	.656	5/8-11	228	5/8-11X2.75
W65-40-SS	W75-40-SS	2.50	5.50	3.750	2.25	3.500	2.502	2.50	.906	7/8-9	236	7/8-9X3.50
W65-48-SS	W75-48-SS	3.00	5.50	3.750	2.25	3.500	3.002	3.00	.906	7/8-9	236	7/8-9X3.50

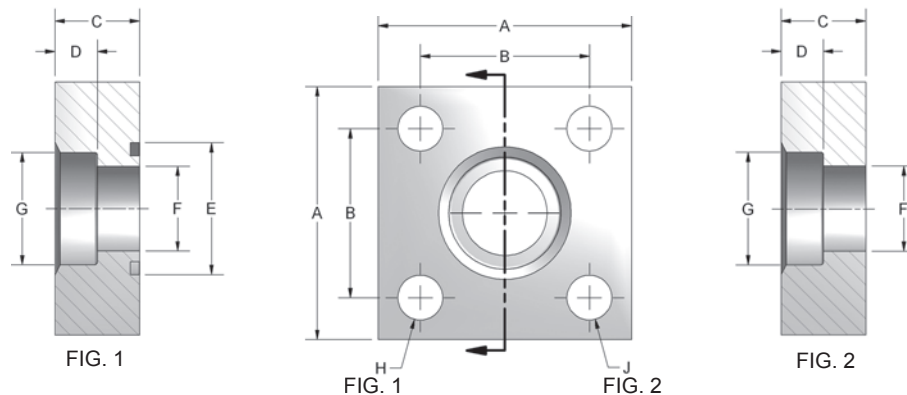

3000 SERIES SQUARE SOCKET WELD - PIPE													
PART NO. O-RING FIG. 1	PART NO. FLAT FACE FIG. 2	PIPE SIZE	A	B	C	D	E	F	G	H	J UNC-2B	MOUNTING HARDWARE	
												O-RING	SHCS
W66-12-SS	W76-12-SS	.75	2.25	1.438	1.00	.50	1.375	.752	1.062	.406	3/8-16	216	3/8-16X1.75
W66-16-SS	W76-16-SS	1.00	3.00	2.000	1.00	.50	1.750	1.002	1.328	.531	1/2-13	222	1/2-13X1.75
W66-20-SS	W76-20-SS	1.25	3.00	2.000	1.00	.50	1.750	1.252	1.672	.531	1/2-13	222	1/2-13X1.75
W66-24-SS	W76-24-SS	1.50	4.00	2.750	1.25	.62	2.500	1.502	1.922	.656	5/8-11	228	5/8-11X2.25
W66-32-SS	W76-32-SS	2.00	4.00	2.750	1.25	.62	2.500	2.002	2.406	.656	5/8-11	228	5/8-11X2.25
W66-40-SS	W76-40-SS	2.50	5.50	3.750	1.50	.75	3.500	2.502	2.906	.906	7/8-9	236	7/8-9X2.75
W66-48-SS	W76-48-SS	3.00	5.50	3.750	1.50	.75	3.500	3.002	3.547	.906	7/8-9	236	7/8-9X2.75
W66-64-SS	W76-64-SS	4.00	7.00	5.000	2.00	.75	4.625	3.880	4.550	1.060	1-8	347	1-8X4.00

Mounting kit available on o-ring grooved flanges by simply adding suffix letter 'U' to part number.

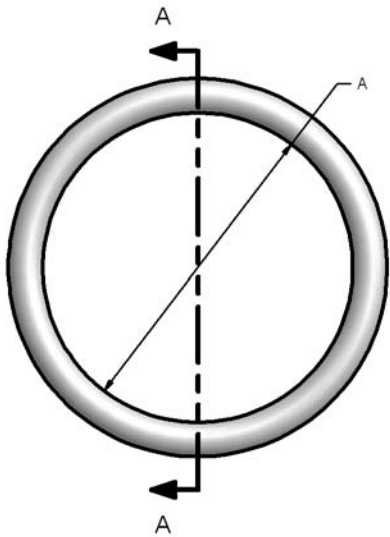

All measurements are in inches.

90 DUROMETER BUNA-N O-RING			
O-RING	SIZE	A	B
210	0.50	0.75	0.125
214	0.75	1.00	0.125
219	1.00	1.31	0.125
222	1.25	1.50	0.125
225	1.50	1.88	0.125
228	2.00	2.25	0.125
232	2.50	2.75	0.125
237	3.00	3.38	0.125
241	3.50	3.88	0.125
245	4.00	4.38	0.125
253	5.00	5.38	0.125

Also Available in Viton

STANDARD "ANCHOR FLUID POWER" O-RING GROOVE

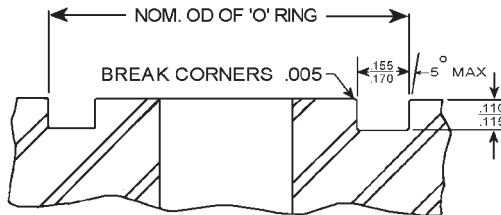

LIMITED WARRANTY

Anchor Fluid Power warrants only that the products conform to the dimensions set forth in its catalog at the time of sale. Catalog dimensions are subject to change. This warranty is made in lieu of all other warranties, expressed or implied. All other warranties, expressed or implied, **INCLUDING ANY WARRANTY OF MERCHANTABILITY OR FITNESS FOR A PARTICULAR PURPOSE**, are excluded and will not apply to the products sold. If buyer disassembles or modifies the unit in any way, warranty is void.

Buyer must obtain written authorization from Anchor Fluid Power prior to returning products. Nonconforming products must be returned to Anchor Fluid Power within 30 days of delivery to buyer.

Internal material defects may not be commercially detectable. Under no circumstances will Anchor Fluid Power be liable for any damages or claims with respect to soundness of material.

No employee, agent, or representative of Anchor Fluid Power has the authority to vary the terms of the warranty described herein, or to extend this warranty to anyone other than Anchor Fluid Power's direct customers.

LIMITATION OF DAMAGES

Buyer's sole and exclusive remedy against Anchor Fluid Power for nonconforming products will be the furnishing of replacement products (F.O.B. Anchor Fluid Power) or refund or credit.

Anchor Fluid Power shall not be liable to buyer, its employees, agents, customers, or to any third party for any claim, loss or damage, general or specific, incidental or consequential, including but not limited to death, personal injury, property damage, lost sales or lost profit, which in any way arises out of or in connection with the sale of any product or the use or nonuse of such products, even if Anchor Fluid Power has been advised of the possibility of such loss or damage.

FLOW, NEEDLE & CHECK VALVES

HYDRAULIC BALL VALVES

WELD COUPLINGS

FLANGES - CARBON STEEL

FLANGES - STAINLESS STEEL

Certificate of Registration



This is to certify that the Quality Management System of:

Anchor Fluid Power
5555 Fair Lane
Cincinnati, OH 45227

See Appendix

applicable to:

Manufacture and distribution of fluid power components and hydraulic flanges

has been assessed and approved by
National Quality Assurance, U.S.A., against the provisions of:

ISO 9001:2008



For and on behalf
of NQA, USA, Acton, MA 01720



Certificate Number: 10496
EAC Code: 18
First Issued: August 6, 1999
Valid Until: March 18, 2014
Reissued: March 31, 2011

Page 1 of 2

This approval is subject to the company maintaining its system to the required standard, which will be monitored by NQA, USA, an accredited organization under the ANSI-ASQ National Accreditation Board.

Certificate of Registration

nqa global assurance

Appendix Number One to Certificate Number 10496

Anchor Fluid Power
5555 Fair Lane
Cincinnati, OH 45227

Includes Facility Located at:

Anchor Fluid Power
6529 Cunningham Road, Suite 2404
Houston, TX 77041

applicable to:

Distribution of fluid power components and hydraulic flanges

has been assessed and approved by
National Quality Assurance, U.S.A., against the provisions of:

ISO 9001:2008

K M Beard

For and on behalf
of NQA, USA, Acton, MA 01720

Certificate Number: 10496
EAC Code: 18
First Issued: August 6, 1999
Valid Until: March 18, 2014
Reissued: March 31, 2011

ANAB
ACCREDITED

Page 2 of 2

This approval is subject to the company maintaining its system to the required standard, which will be monitored by NQA, USA, an accredited organization under the ANSI-ASQ National Accreditation Board.

FLOW, NEEDLE & CHECK VALVES
HYDRAULIC BALL VALVES
WELD COUPLINGS
FLANGES - CARBON STEEL
FLANGES - STAINLESS STEEL



FLOW, NEEDLE & CHECK VALVES

HYDRAULIC BALL VALVES

WELD COUPLINGS

FLANGES - CARBON STEEL

FLANGES - STAINLESS STEEL

Certificate of Registration



This is to certify that the Environmental Management System of:

Anchor Fluid Power
5555 Fair Lane
Cincinnati, OH 45227

See Appendix

applicable to:

Manufacture and distribution of fluid power components and hydraulic flanges

has been assessed and approved by
National Quality Assurance, U.S.A., against the provisions of:

ISO 14001: 2004



For and on behalf
of NQA, USA, Acton, MA 01720



Certificate Number: EN10496

First Issued: March 18, 2011

Valid Until: March 18, 2014

Page 1 of 2

This approval is subject to the company maintaining its system to the required standard, which will be monitored by NQA, USA, an accredited organization under the ANSI-ASQ National Accreditation Board.

Certificate of Registration



Appendix Number One to Certificate Number EN10496

Anchor Fluid Power
5555 Fair Lane
Cincinnati, OH 45227

Includes Facility Located at:

Anchor Fluid Power
6529 Cunningham Road, Suite 2404
Houston, TX 77041

applicable to:

Distribution of fluid power components and hydraulic flanges

has been assessed and approved by
National Quality Assurance, U.S.A., against the provisions of:

ISO 14001: 2004



For and on behalf
of NQA, USA, Acton, MA 01720



Certificate Number: EN10496

First Issued: March 18, 2011

Valid Until: March 18, 2014

Page 2 of 2

This approval is subject to the company maintaining its system to the required standard, which will be monitored by NQA, USA, an accredited organization under the ANSI-ASQ National Accreditation Board.

FLOW, NEEDLE & CHECK VALVES

HYDRAULIC BALL VALVES

WELD COUPLINGS

FLANGES - CARBON STEEL

FLANGES - STAINLESS STEEL



FLOW, NEEDLE & CHECK VALVES

30065
 300*107
 30265
 30466
 34066
 34466
 39067

HYDRAULIC BALL VALVES

390*107
 39467
 60065
 600*107
 60265
 60466
 64066
 64466
 69067

WELD COUPLINGS

690*107
 69467
 82057
 82550
 83050
 83551
 835B51

FLANGES - CARBON STEEL

84057
 84553
 845B53
 85054
 855B55
 86054
 86552
 88056
 88556

FLANGES - STAINLESS STEEL

145372
 5143773
 AB218
 AB328
 ABF36

ABS/F38
 ABS32
 ACB/ACBX76
 ADOS/ADOSX77
 AE216
 AE324
 AE3K26
 AEF34
 AES/F38
 AES30
 AFA/AFAC80
 AOP/AOPX79
 APK40
 AS/ASX78
 AV220
 AV322
 C0020ZB43
 C10106H43
 C1010ZB43
 C1200ZB43
 C2950AV43
 C69206H43
 C81302B43
 C81306H43
 C92501Z43
 CN4
 CP/CPX76
 CS4
 F-FO70
 FN6
 FOP/FP75
 FOPX/FPX75
 FS6
 LK42
 LV2B44
 MV2B45
 NN8

NS.....	.8	W16898
P-BWSF/P-BWSFN68	W16999
P-BWSFX/P-BWSFXN69	W169*.....	115
PTX.....	.74	W1797
P-WSF70	W17*.....	117
SF-2/SFX-2.....	.64	W17098
SF-2/SFX-2*.....	106	W172	100
S-FO.....	.70	W17699
SFW/SFTW64	W176*.....	115
SFW/SFTW*.....	106	W177	100
SFXW/SFXTW64	W1897
SFXW/SFXTW*.....	106	W18*.....	117
SP/SPX.....	.82	W18098
T-SF/T-SFN71	W182	100
T-SFX/T-SFXN71	W18498
W10483	W18598
W104*.....	109	W18699
W10684	W186*.....	115
W106*.....	110	W187	100
W1296	W18898
W12*	116	W18999
W1396	W189*.....	115
W13*	116	W1997
W1496	W19*.....	117
W14*	116	W19285
W1596	W19385
W15*	116	W19485
W1697	W19585
W16*.....	117	W2295
W1797	W2392
W17*	117	W23*.....	113
W1897	W2492
W18*	117	W24*.....	113
W1997	W2592
W19*	117	W25*.....	113
W16498	W2693
W16598	W26*.....	114

FLOW, NEEDLE & CHECK VALVES
HYDRAULIC BALL VALVES
WELD COUPLINGS
FLANGES - CARBON STEEL
FLANGES - STAINLESS STEEL



FLOW, NEEDLE & CHECK VALVES

W2792
 W27*113
 W2893
 W28*114
 W2993
 W29*114
 W390

HYDRAULIC BALL VALVES

W3*112
 W3093
 W30*114
 W30086
 W30487
 W3190
 W31*112
 W3293
 W32*114

WELD COUPLINGS

W3393
 W33*114
 W3492
 W34*113
 W3592
 W35*113
 W3681
 W36*108
 W3781
 W37*108
 W3881
 W38*108
 W3981
 W39*108

FLANGES - CARBON STEEL

W488
 W4*111
 W4383
 W43*109
 W4483
 W44*109
 W4583

FLANGES - STAINLESS STEEL

W45*109
 W4684
 W46*110
 W4884
 W48*110
 W4984
 W49*110
 W591
 W5191
 W5370
 W56102
 W57102
 W5889
 W5988
 W59*111
 W689
 W6088
 W60*111
 W60086
 W60487
 W6188
 W61*111
 W6289
 W6389
 W65101
 W65*118
 W66101
 W66*118
 W6994
 W794
 W7288
 W72*111
 W75101
 W75*118
 W76101
 W76*118
 W894

W8090
W80*112
W8190
W81*112
W8794
W9188
W91*111

*Stainless Steel

FLOW, NEEDLE & CHECK VALVES

HYDRAULIC BALL VALVES

WELD COUPLINGS

FLANGES - CARBON STEEL

FLANGES - STAINLESS STEEL

